

# **CPUC Self-Generation Incentive Program Eleventh-Year Impact Evaluation**

## **Final Report**

Submitted to:

**PG&E  
and  
The Self-Generation Incentive Program  
Working Group**

Prepared by:

Itron, Inc.  
2800 Fifth Street  
Suite 110  
Davis, California 95618

June 22, 2012

## **ACKNOWLEDGEMENTS**

We would like to acknowledge the following for their contributions to the 2011 Self-Generation Incentive Program (SGIP) Impact Evaluation Report:

- Andrea Riemann at PG&E for providing guidance on the report approach and content; as well as feedback on earlier drafts;
- Ehren Seybert at the CPUC, the SGIP Program Administrators and IOU representatives (PG&E, SCE, SCG, SDG&E, and CCSE) for their review of an earlier presentation of results and a draft version of the report as well as their assistance in obtaining required and critical information for this report; and
- Those third-party data providers who supplied performance data for this report.

# Glossary

Term	Definition
Active Project	Projects that have not been withdrawn, rejected, completed, or placed on a wait list. Active projects will eventually migrate either to the Complete or Inactive category.
AES	Advanced Energy Storage
Applicant (as defined for SGIP)	The entity, either the Host Customer, System Owner, or third party designated by the Host Customer, that is responsible for the development and submission of the SGIP application materials and the main point of communication between the SGIP Program Administrator for a specific SGIP Application.
Biogas	A gas composed primarily of methane and carbon dioxide produced by the anaerobic digestion of organic matter. This is a renewable fuel. Biogas is typically derived from landfills, wastewater treatment facilities, food processing facilities employing digesters and dairy operations employing digesters.
California Independent System Operator (CAISO)	A non-profit public benefit corporation charged with operating the majority of California’s high-voltage wholesale power grid.
Capacity Factor	The ratio of electrical energy generated to the electrical energy that would be produced by the generating system at full capacity during the same period.
CCSE	California Center for Sustainable Energy (Formerly San Diego Regional Energy Office)
CEC	California Energy Commission
CO <sub>2</sub>	Carbon Dioxide
CO <sub>2</sub> Equivalent (CO <sub>2</sub> Eq)	Carbon Dioxide Equivalent. When reporting emission impacts from different types of greenhouse gases, total GHG emissions are reported in terms of tons of CO <sub>2</sub> equivalent so that direct comparisons can be made across technologies and fuel types. To calculate the CO <sub>2</sub> Eq, the global warming potential of a gas as compared to that of CO <sub>2</sub> is used as the conversion factor (e.g., The global warming potential of CH <sub>4</sub> is 21 times that of CO <sub>2</sub> . Thus, to calculate the CO <sub>2</sub> Eq of a given amount of CH <sub>4</sub> , you multiply that amount by the conversion factor of 21.
Combined Heat and Power (CHP)	A facility where both electricity and useful heat are produced simultaneously (used interchangeably with “cogeneration”).
Commercial	Commercial entities are defined as non-manufacturing business establishments, including hotels, motels, restaurants, wholesale businesses, retail stores, and for-profit health, social, and educational institutions.
Complete Project	Projects where the generation or storage system has been installed, verified through on-site inspections, and an incentive check has been issued.

<b>Term</b>	<b>Definition</b>
Confidence Interval	A particular kind of interval estimate of a population parameter used to indicate the reliability of an estimate. It is an observed interval (i.e., calculated from observations), in principle different from sample to sample, that frequently includes the parameter of interest, if the experiment is repeated. How frequently the observed interval contains the parameter is determined by the confidence level or confidence coefficient. A confidence interval with a particular confidence level is intended to give the assurance that, if the statistical model is correct, then taken over all the data that might have been obtained, the procedure for constructing the interval would deliver a confidence interval that included the true value of the parameter the proportion of the time set by the confidence level.
Confidence Level (also Confidence Coefficient)	The degree of accuracy resulting from the use of a statistical sample. For example, if a sample is designed at the 90/10 confidence (or precision) level, the resultant sample estimate will be within $\pm 10$ percent of the true value, 90 percent of the time.
CPUC	California Public Utilities Commission
Decommissioned Project	Decommissioned projects are ones where the SGIP equipment has been removed from the project site.
DG	Distributed Generation
Directed Biogas	Biogas delivered through a natural gas pipeline system and its nominal equivalent used at a distant customer's site. This is a renewable fuel.
Electrical Conversion Efficiency (ECE)	The ratio of electrical energy produced to the fuel (lower heat value) energy used.
FC-N	Fuel Cells (Non-renewable)
FC-R	Fuel Cells (Renewable)
Flaring (of Biogas)	Within the context of this report, flaring refers to a basis of how biogas is treated for GHG emission accounting purposes. A basis of flaring means that prior to the installation of an SGIP rebated project, the facility was assumed to be flaring (burning and converting from CH <sub>4</sub> to CO <sub>2</sub> ) the biogas that is currently fed to the generator. <i>See also: Venting (of Biogas).</i>
Greenhouse Gas (GHG) Emissions	For the purposes of this analysis GHG emissions refer specifically to CO <sub>2</sub> Equivalent.
GT-N	Gas Turbines (Non-renewable-fueled)
GT-R	Gas Turbines (Renewable-fueled)
Heat Recovery Rate	The ratio of heat energy produced to the electrical energy produced.
IC Engine-N	Internal Combustion Engines (Non-renewable-fueled)
IC Engine-R	Internal Combustion Engines (Renewable-fueled)
Inactive Project	No longer progressing in SGIP implementation process because they have been withdrawn by applicant or rejected by PA.
IOU	Investor-Owned Utility



<b>Term</b>	<b>Definition</b>
Load	Either the device or appliance which consumes electric power, or the amount of electric power drawn at a specific time from an electrical system, or the total power drawn from the system. Peak load is the amount of power drawn at the time of highest demand.
Lower Heating Value (LHV)	A measure of energy released from a fuel that assumes water exits the combustion process in a gaseous state.
Higher Heating Value (HHV)	A measure of energy released from a fuel that assumes water exits the combustion process in a liquid state.
Marginal Heat Rate	Heat rate is a measurement used to calculate how efficiently a generator uses heat energy (or its efficiency in converting fuel to electricity). It is expressed as the number of Btus of heat required to produce a kilowatt-hour of energy. The marginal heat rate is the amount of source energy that is saved as a result of a change in generation.
MT-N	Microturbines (Non-renewable-fueled)
MT-R	Microturbines (Renewable-fueled)
NEM	Net Energy Metering
NOx	NOx refers to nitric oxide (NO) and nitrogen dioxide (NO <sub>2</sub> ).
On site Biogas	On site biogas refers to biogas projects where the biogas source is located directly at the host site where the SGIP system is located.
On-line Project	Projects that have entered normal operations but may be only operational for a limited time during 2011
PA	Program Administrator
PG&E	Pacific Gas and Electric Company
PM-10	Particulate matter (PM) with diameter of 10 micrometers or less.
POU	Publicly-owned Utility
PPA	Power Purchase Agreement
PV	Photovoltaics
PY	Program Year
Rebated Capacity	The capacity rating associated with the rebate (incentive) provided to the program participant. The rebated capacity may be lower than the typical “nameplate” rating of the technology.
Total Waste Heat	Total waste heat refers to the amount of waste heat delivered at the back end of a CHP prime mover and is recoverable for possible end use. However, if heat demand at the host site is lower than the total waste heat, some thermal energy must be dumped to the atmosphere. <i>See also: Useful Waste Heat.</i>
SCE	Southern California Edison
SCG	Southern California Gas Company
SDG&E	San Diego Gas and Electric Company
SGIP	Self-Generation Incentive Program

<b>Term</b>	<b>Definition</b>
System Owner	The owner of the SGIP system at the time the incentive is paid. For example, in the case when a vendor sells a turnkey system to a Host Customer, the Host Customer is the System Owner. In the case of a leased system, the lessor is the System Owner.
System Size	This is the manufacturer rated nominal size that approximates the generator's highest capacity to generate electricity under specified conditions.
Term	Definition
Useful Waste Heat	This is the heat actually delivered and used to meet the on-site heating demand for a specific process or application at the host site. Useful waste heat may differ significantly from total waste heat referred to in CHP manufacturer specifications. <i>See also: Total Waste Heat</i>
Venting (of Biogas)	Within the context of this report, venting refers to a basis of how biogas is treated for GHG emission accounting purposes. A basis of venting means that prior to the installation of an SGIP rebated project, the facility was assumed to be venting (releasing CH <sub>4</sub> ) the biogas that is currently fed to the generator. . <i>See also: Flaring (of Biogas).</i>
WD	Wind Turbines

# Table of Contents

---

<b>1 Executive Summary .....</b>	<b>1-1</b>
Abstract.....	1-1
1.1 Conclusions & Recommendations .....	1-2
1.2 Introduction & Background.....	1-4
Key Take-Aways.....	1-4
1.3 Program-Status.....	1-6
Key Take-Aways:.....	1-6
1.4 Electric Energy Impacts .....	1-7
Key Take-Aways.....	1-7
1.5 Peak Demand Impacts.....	1-8
Key Take-Aways:.....	1-8
1.6 Efficiency and Waste Heat Utilization .....	1-9
Key Take-Aways:.....	1-9
1.7 Greenhouse Gas Emission Reduction Impacts .....	1-10
Key Take-Aways:.....	1-10
<b>2 Introduction .....</b>	<b>2-1</b>
2.1 Program Background.....	2-1
2.2 Recent Changes in the SGIP Handbook.....	2-3
2.3 Impact Evaluation Requirements .....	2-4
2.4 Scope of this Report .....	2-5
2.4.1 Impact Evaluation Objectives .....	2-5
2.5 Report Organization.....	2-6
<b>3 Program Status.....</b>	<b>3-1</b>
3.1 Introduction .....	3-1
3.2 Geographical Distribution.....	3-1
3.3 Background.....	3-3
3.3.1 Definitions.....	3-3
3.3.2 Implementation Status.....	3-3
3.3.3 Program Trends.....	3-4
3.4 Technology and Fuel Type Characteristics .....	3-6
3.4.1 SGIP Complete Projects .....	3-6
3.4.2 SGIP Active Projects .....	3-10
3.5 Financial and Cost Characteristics.....	3-10
3.5.1 Incentives Paid .....	3-10
3.5.2 Incentives Reserved.....	3-12
3.6 Participants' Out-of-pocket Costs after SGIP Incentive.....	3-14
3.6.1 Participants' Out-of-pocket Costs for Complete Projects .....	3-14
3.6.2 Participants' Out-of-pocket Costs for Active Projects.....	3-15
3.6.3 Leveraging of SGIP Funding.....	3-16
3.7 Program Administrator Characteristics .....	3-17
3.7.1 Complete SGIP Projects by PA.....	3-17

3.7.2 Active SGIP Projects by PA .....	3-19
3.7.3 Overlap of SGIP Projects between IOU and Municipal Utilities .....	3-20
3.8 Key Observations.....	3-21
<b>4 Electric Energy and Demand Impacts .....</b>	<b>4-1</b>
4.1 Introduction .....	4-1
4.2 The Importance of Capacity and Utilization .....	4-1
4.2.1 Changes in Program Capacity over Time .....	4-2
4.2.2 Changes in Utilization over Time.....	4-3
4.3 Technology Utilization Trends.....	4-5
4.3.1 Overview of Program Capacity by Technology .....	4-5
4.3.2 IC Engine Utilization Trends.....	4-6
4.3.3 Microturbine Utilization Trends.....	4-11
4.3.4 Gas Turbine Utilization Trends.....	4-14
4.3.5 Fuel Cell Utilization Trends .....	4-15
4.3.6 Program Annual Capacity Factor Trends.....	4-17
4.4 Program Impact Trends .....	4-18
4.4.1 Demand Impacts .....	4-19
4.4.2 Program Energy Impacts.....	4-24
4.5 Program Administrator Impact Trends .....	4-27
4.6 Key Observations.....	4-30
<b>5 Efficiency and Waste Heat Utilization.....</b>	<b>5-1</b>
5.1 Introduction .....	5-1
5.1.1 Terms and Definitions .....	5-1
5.2 PUC 216.6 Compliance .....	5-5
5.3 AB 1685 (60%) Efficiency Status .....	5-10
5.4 California Air Resources Board (CARB) NOx Compliance .....	5-11
5.5 Fuel and Heat Trends .....	5-13
5.6 Key Observations.....	5-17
<b>6 Greenhouse Gas Emission Impacts .....</b>	<b>6-1</b>
6.1 Overview .....	6-1
6.2 GHG Analysis Approach .....	6-1
6.2.1 GHG Analysis Results.....	6-4
6.3 Trends in Greenhouse Gas Emissions Impacts.....	6-19
6.4 Key Observations.....	6-25
<b>Appendix A Energy and Demand Impacts and Trends .....</b>	<b>A-1</b>
A.1 Overview .....	A-1
A.1.1 Appendix A Energy and Demand Impacts and Trends .....	A-1
A.1.2 2011 Annual Energy .....	A-2
A.1.3 2011 Peak Demand Impacts.....	A-5
A.1.4 2011 Capacity Factors .....	A-14
A.2 Renewable Fuel Projects.....	A-19
A.2.1 Renewable Fuel Cells.....	A-19
A.2.2 Renewable Internal Combustion Engines and Microturbines.....	A-26
A.3 Non-Renewable Fuel Projects.....	A-34
A.3.1 Non-renewable Fuel Cells.....	A-34
A.3.2 Non-renewable Gas Turbines, Internal Combustion Engines, and Microturbines...	A-39
A.4 Annual Trends .....	A-50

A.4.1 Growth in Capacity and Annual Impacts by Year .....	A-51
Annual Capacity Factor and Off-line Trends with Age .....	A-54
CAISO Peak Hour Capacity Factor and Off-line Trends with Age .....	A-58
2011 Decommissioned and Off-line Capacities by Project Vintage .....	A-62
<b>Appendix B Greenhouse Gas Emissions Impacts Methodology .....</b>	<b>B-1</b>
B.1 Overview .....	B-1
B.2 SGIP System GHG Emissions .....	B-4
B.2.1 Emissions from Rebated SGIP Systems .....	B-5
B.2.2 Heating and Cooling Services Provided by SGIP CHP Systems .....	B-6
B.3 Baseline GHG Emissions .....	B-8
B.3.1 Electric Power Plant GHG Emissions .....	B-8
B.3.2 Natural Gas Boiler GHG Emissions .....	B-11
B.3.3 Biogas GHG Emissions .....	B-12
B.4 Emission Details by PA, Technology and Fuel .....	B-17
<b>Appendix C Data Sources and Data Analysis.....</b>	<b>C-1</b>
C.1 Overview of Key Data Types.....	C-1
C.1.1 Project Lists Maintained by Program Administrators.....	C-1
C.1.2 Reports from Monitoring Planning and Installation Verification Site Visits .....	C-2
C.1.3 Metered Performance Data .....	C-2
C.2 Data Processing Methods .....	C-4
C.2.1 ENGO Data Processing.....	C-4
C.2.2 HEAT Data Processing.....	C-4
C.2.3 FUEL Data Processing .....	C-5
C.3 Estimating Impacts of Unmetered Systems.....	C-5
C.4 Assessing Uncertainty of Impacts Estimates.....	C-7
C.4.1 Electricity, Fuel, and Heat Impacts .....	C-7
C.4.2 GHG Emission Impacts .....	C-8
C.4.3 Data Sources .....	C-9
C.4.4 Analytic Methodology.....	C-10
C.4.5 Results .....	C-31
<b>Appendix D Cumulative System Cost and Incentive Trends.....</b>	<b>D-1</b>

## **List of Figures**

Figure 3-1: Distribution of SGIP Projects by Electric Service Territory .....	3-2
Figure 3-2: SGIP Projects Status by Rebated Capacity .....	3-4
Figure 3-3: Rebated Capacity Trends by Fuel Type.....	3-5
Figure 3-4: Rebated Capacity Trends by Technology .....	3-6
Figure 3-5: Quantity and Capacity by Technology .....	3-7
Figure 3-6: Quantity and Capacity by Fuel Type .....	3-9
Figure 3-7: Quantity of Incentives Paid (\$ Millions) by Technology Type.....	3-11
Figure 3-8: Quantity of Incentives Reserved (\$ Millions) by Technology Type.....	3-13
Figure 3-9: Incentives Paid by Fuel Type.....	3-14
Figure 3-10: Weighted Participants' Out-of-pocket Cost on Complete Projects ..	3-15
Figure 3-11: Weighted Participants' Out-of-pocket Cost on Active Projects.....	3-16
Figure 3-12: Ratio of Other Funding to SGIP Incentive Funding by Program Year	3-17
Figure 3-13: Distribution of Technology Type by PA (Complete Projects).....	3-19
Figure 4-1: Cumulative Program Capacity Growth (without Wind) .....	4-2
Figure 4-2: Annual Capacity Additions by Technology .....	4-5
Figure 4-3: Mean Ages of Program Aggregate Capacities by Technology .....	4-6
Figure 4-4: ICE-N Annual Capacity Factor and Project Age.....	4-7
Figure 4-5: ICE-N Annual Energy Impact and End-of Year Aggregate Capacity....	4-8
Figure 4-6: ICE-N CAISO Peak Hour Capacity Factor and Project Age.....	4-9
Figure 4-7: 2011 ICE Retired Capacity by Project Vintage.....	4-10
Figure 4-8: MT-N Annual Capacity Factor and Project Age .....	4-11
Figure 4-9: MT-N CAISO Peak Hour Capacity Factor and Project Age.....	4-12
Figure 4-10: 2011 CAISO Peak Day Hourly Capacity Factors .....	4-13
Figure 4-11: GT-N Annual Capacity Factor and Project Age.....	4-14
Figure 4-12: FC-N Annual Capacity Factor and Project Age.....	4-15
Figure 4-13: FC-N CAISO Peak Hour Capacity Factor and Project Age .....	4-16
Figure 4-14: Calendar Year Annual Mean Capacity Factors .....	4-17
Figure 4-15: Mean Annual Capacity Factor Trends with Age .....	4-18
Figure 4-16: CAISO Annual Peak Hours from 2002 to 2011 .....	4-19
Figure 4-17: Program CAISO Top 2000 Peak Hour Capacity Factors .....	4-23

Figure 4-18: Program Annual Energy Contribution History ..... 4-26

Figure 4-19: Investor-owned Utilities 2011 Peak Demand Days ..... 4-30

Figure 5-1: Energy Flow Schematic ..... 5-1

Figure 5-2: Energy Flow Schematic for Hypothetical IC Engine ..... 5-2

Figure 5-3: PUC 216.6(b) Compliance ..... 5-7

Figure 5-4: Metered Microturbine and IC Engine PUC 216.6(b) Project Efficiencies ..... 5-8

Figure 5-5: Total Project Efficiency, LHV..... 5-11

Figure 5-6: Electrical and Thermal Energy by Year and Technology ..... 5-14

Figure 5-7: Electrical and Thermal Energy by Year, Technology, and Fuel ..... 5-15

Figure 5-8: Electrical and Thermal Energy by Year for Fuel Cells..... 5-16

Figure 5-9: Electrical and Thermal Energy by Year for IC Engines ..... 5-17

Figure 6-1: GHG Impacts Assumptions for Non-renewable Systems..... 6-2

Figure 6-2: Monthly Energy Produced by IC Engines in 2011 ..... 6-3

Figure 6-3: CO<sub>2</sub> Emission Rates for Non-renewable Projects in 2011 ..... 6-8

Figure 6-4: GHG Emission Impacts Associated with On-site Renewable DG ..... 6-9

Figure 6-5: CO<sub>2</sub> Emission Rates from Biogas Projects in 2011 - Flared CH<sub>4</sub> Baseline ..... 6-14

Figure 6-6: CO<sub>2</sub> (and CO<sub>2</sub>Eq) Emission Rates from Biogas Projects in 2011 – Vented CH<sub>4</sub> Baseline..... 6-15

Figure 6-7: Geographic Distribution of SGIP GHG Emission Impacts (Includes Tons of CO<sub>2</sub> and CO<sub>2</sub>Eq) ..... 6-19

Figure 6-8: Trends in CO<sub>2</sub> (and CO<sub>2</sub>Eq) Emission Impacts by Fuel Type ..... 6-20

Figure 6-9: Trends in CO<sub>2</sub> (and CO<sub>2</sub>Eq) Emission Impacts by Technology and Fuel Type ..... 6-21

Figure 6-10: Trends in CO<sub>2</sub> (and CO<sub>2</sub>Eq) Emissions Impacts and Rebated Capacity for Renewable Fuel Cells ..... 6-22

Figure 6-11: Trends in CO<sub>2</sub> (and CO<sub>2</sub>Eq) Emission Impacts and Rebated Capacity for Non-renewable IC Engines ..... 6-23

Figure 6-12: Trends in CO<sub>2</sub> (and CO<sub>2</sub>Eq) Emission Impacts and Avoided Heating/Cooling Emissions for Non-renewable IC Engines ..... 6-24

Figure 6-13: Program Trends in CO<sub>2</sub> (and CO<sub>2</sub>Eq) Emission Impacts and Incentives Paid..... 6-25

Figure A-1: 2011 CAISO Peak Day Output by Technology ..... A-6

Figure A-2: 2011 CAISO Peak Day Output by Technology, and Fuel—PG&E.... A-10

Figure A-3: 2011 CAISO Peak Day Output by Technology, and Fuel—SCE ..... A-11

Figure A-4: 2011 CAISO Peak Day Output by Technology, and Fuel—SDG&E . A-11

Figure A-5: 2011 Monthly Capacity Factors by Technology ..... A-16

Figure A-6: 2011 CAISO Peak Day Capacity Factors by Technology ..... A-17

Figure A-7: 2011 IOU Peak Day Capacity Factors by Technology—PG&E ..... A-18

Figure A-8: 2011 IOU Peak Day Capacity Factors by Technology—SCE ..... A-18

Figure A-9: 2011 IOU Peak Day Capacity Factors by Technology—SDG&E..... A-19

Figure A-10: 2011 Monthly Capacity Factors by PA..... A-22

Figure A-11: 2011 CAISO Peak Day Capacity Factors by PA..... A-23

Figure A-12: 2011 IOU Peak Day Capacity Factors—PG&E ..... A-24

Figure A-13: 2011 IOU Peak Day Capacity Factors—SCE ..... A-24

Figure A-14: 2011 IOU Peak Day Capacity Factors—SDG&E ..... A-25

Figure A-15: 2011 Monthly Capacity Factors by PA—ICE-R ..... A-29

Figure A-16: 2011 Monthly Capacity Factors by PA—MT-R ..... A-30

Figure A-17: 2011 CAISO Peak Day Capacity Factors by PA—ICE-R ..... A-31

Figure A-18: 2011 CAISO Peak Day Capacity Factors by PA—MT-R ..... A-31

Figure A-19: 2011 IOU Peak Day Capacity Factors by Technology—PG&E ..... A-32

Figure A-20: 2011 IOU Peak Day Capacity Factors by Technology—SCE ..... A-33

Figure A-21: 2011 IOU Peak Day Capacity Factors by Technology—SDG&E.... A-33

Figure A-22: 2011 Monthly Capacity Factors by Technology and PA ..... A-36

Figure A-23: 2011 CAISO Peak Day Capacity Factors by PA..... A-37

Figure A-24: 2011 IOU Peak Day Capacity Factors—PG&E ..... A-38

Figure A-25: 2011 IOU Peak Day Capacity Factors—SCE ..... A-38

Figure A-26: 2011 IOU Peak Day Capacity Factors—SDG&E ..... A-39

Figure A-27: 2011 Monthly Capacity Factors by Technology—GT ..... A-43

Figure A-28: 2011 Monthly Capacity Factors by Technology—ICE-N..... A-43

Figure A-29: 2011 Monthly Capacity Factors by Technology—MT-N..... A-44

Figure A-30: 2011 CAISO Peak Day Capacity Factors by Technology ..... A-45

Figure A-31: 2011 CAISO Peak Day Capacity Factors by Technology and PA—  
GT ..... A-46

Figure A-32: 2011 CAISO Peak Day Capacity Factors by Technology and PA—  
ICE-N ..... A-47



Figure A-33: 2011 CAISO Peak Day Capacity Factors by Technology and PA—  
 MT-N ..... A-48

Figure A-34: 2011 IOU Peak Day Capacity Factors by Technology—PG&E ..... A-49

Figure A-35: 2011 IOU Peak Day Capacity Factors by Technology—SCE..... A-49

Figure A-36: 2011 IOU Peak Day Capacity Factors by Technology—SDG&E.... A-50

Figure A-37: FC-N Capacity and Annual Impacts by Year ..... A-51

Figure A-38: FC-R Capacity and Annual Impacts by Year ..... A-51

Figure A-39: ICE-N Capacity and Annual Impacts by Year ..... A-52

Figure A-40: ICE-R Capacity and Annual Impacts by Year ..... A-52

Figure A-41: GT Capacity and Annual Impacts by Year..... A-53

Figure A-42: MT-N Capacity and Annual Impacts by Year ..... A-53

Figure A-43: MT-R Capacity and Annual Impacts by Year..... A-54

Figure A-44: FC-N Annual Capacity Factor and Off-line by Age ..... A-54

Figure A-45: FC-R Annual Capacity Factor and Off-line by Age ..... A-55

Figure A-46: GT- Annual Capacity Factor and Off-line by Age..... A-55

Figure A-47: ICE-N Annual Capacity Factor and Off-line by Age ..... A-56

Figure A-48: ICE-R Annual Capacity Factor and Off-line by Age ..... A-56

Figure A-49: MT-N Annual Capacity Factor and Off-line by Age..... A-57

Figure A-50: MT-R Annual Capacity Factor and Off-line by Age..... A-57

Figure A-51: FC-N CAISO Peak Hour Capacity Factor and Off-line by Age ..... A-58

Figure A-52: FC-R CAISO Peak Hour Capacity Factor and Off-line by Age ..... A-58

Figure A-53: GT CAISO Peak Hour Capacity Factor and Off-line by Age ..... A-59

Figure A-54: ICE-N CAISO Peak Hour Capacity Factor and Off-line by Age ..... A-59

Figure A-55: ICE-R CAISO Peak Hour Capacity Factor and Off-line by Age ..... A-60

Figure A-56: MT-N CAISO Peak Hour Capacity Factor and Off-line by Age ..... A-60

Figure A-57: MT-R CAISO Peak Hour Capacity Factor and Off-line by Age ..... A-61

Figure A-58: 2011 Capacities Decommissioned, Off-line, and On-line by VintageA-62

Figure A-59: 2011 FC Capacities Decommissioned, Off-line, and On-line by  
 Vintage..... A-62

Figure A-60: 2011 GT Capacities Decommissioned, Off-line, and On-line by  
 Vintage..... A-63

Figure A-61: 2011 ICE Capacities Decommissioned, Off-line, and On-line by  
 Vintage..... A-63

Figure A-61: 2011 MT Capacities Decommissioned, Off-line, and On-line by Vintage..... A-64

Figure B-1: Graphical Depiction of GHG Impacts Equation for Non-Renewable Systems ..... B-4

Figure B-2: Landfill Gas with CH<sub>4</sub> Capture Diagram..... B-15

Figure C-1: Non-Renewable-Fueled Microturbine Measured Coincident Peak Output ..... C-13

Figure C-2: Renewable-Fueled Fuel Cell Measured Coincident Peak Output.... C-14

Figure C-3: Peak CF Distribution used in MCS for Renewable-Fueled Fuel CellsC-15

Figure C-4: Fuel Cell Measured Coincident Peak Output (Non-Renewable Fuel)C-17

Figure C-5: MCS Distribution –Fuel Cell Coincident Peak Output (Non-Renewable Fuel) ..... C-17

Figure C-6: Fuel Cell Measured Coincident Peak Output (Renewable Fuel) ..... C-18

Figure C-7: MCS Distribution –Fuel Cell Coincident Peak Output (Renewable Fuel)..... C-18

Figure C-8: IC Engine Measured Coincident Peak Output (Non-Renewable Fuel)C-19

Figure C-9: MCS Distribution—IC Engine Coincident Peak Output (Non-Renewable Fuel) ..... C-19

Figure C-10: IC Engine Measured Coincident Peak Output (Renewable Fuel)... C-20

Figure C-11: MCS Distribution—IC Engine Coincident Peak Output (Renewable Fuel)..... C-20

Figure C-12: Gas Turbine Measured Coincident Peak Output (Non-Renewable Fuel)..... C-21

Figure C-13: MCS Distribution—Gas Turbine Coincident Peak Output (Non-Renewable Fuel) ..... C-21

Figure C-14: Microturbine Measured Coincident Peak Output (Non-Renewable Fuel)..... C-22

Figure C-15: MCS Distribution—Microturbine Coincident Peak Output (Non-Renewable Fuel) ..... C-22

Figure C-16: Microturbine Measured Coincident Peak Output (Renewable Fuel)C-23

Figure C-17: MCS Distribution—Microturbine Coincident Peak Output (Renewable Fuel)..... C-23

Figure C-18: Fuel Cell Measured Energy Production (Capacity Factor)..... C-24

Figure C-19: MCS Distribution—Fuel Cell Energy Production (Capacity Factor) C-24

Figure C-20: Engine/Turbine (Non-Renewable) Measured Electricity Production (Capacity Factor)..... C-25

Figure C-21: MCS Distribution—Engine/Turbine (Non-Renewable) Electricity Production (Capacity Factor)..... C-25

Figure C-22: Engine/Turbine (Renewable) Measured Electricity Production (Capacity Factor)..... C-26

Figure C-23: MCS Distribution—Engine/Turbine (Renewable) Electricity Production (Capacity Factor)..... C-26

Figure C-24: Fuel Cell (Non-Renewable) Measured Heat Recovery Rate ..... C-27

Figure C-25: MCS Distribution—Fuel Cell (Non-Renewable) Heat Recovery RateC-27

Figure C-26: Engine/Turbine Measured Heat Recovery Rate ..... C-28

Figure C-27: MCS Distribution—Engine/Turbine Heat Recovery Rate ..... C-28

**List of Tables**

Table 1-1: Key Terms in SGIP 2011 Evaluation Report ..... 1-5

Table 2-1: SGIP Technologies and Applicable Program Years ..... 2-4

Table 3-1: Quantity and Capacity of Complete Projects by Technology ..... 3-7

Table 3-2: Operation Status of Complete Projects by Technology Type ..... 3-8

Table 3-3: Operation Status of Complete Projects by Fuel Type ..... 3-9

Table 3-4: Project Characteristics of Active Projects ..... 3-10

Table 3-5: Rebated Capacity and Incentives Paid ..... 3-11

Table 3-6: Incentives Reserved for Active Projects ..... 3-12

Table 3-7: Participants’ Out-of-pocket Costs for Complete Projects ..... 3-14

Table 3-8: Participants’ Out-of-pocket Costs for Active Projects ..... 3-15

Table 3-9: Quantity and Capacity of Complete Projects by PAs ..... 3-18

Table 3-10: Quantity and Capacity of Active Projects by PAs ..... 3-20

Table 3-11: Overlap of IOU and Municipal for On-line Projects ..... 3-20

Table 4-1: 2011 CAISO Peak Hour Impacts and Capacity Factors ..... 4-20

Table 4-2: CAISO Peak Hour Impact Trends ..... 4-21

Table 4-3: CAISO Annual Peak Hour Capacity Factor Trends ..... 4-22

Table 4-4: Program 2011 Energy Impacts by Technology ..... 4-24

Table 4-5: Program 2011 Quarterly Energy Impacts ..... 4-25

Table 4-6: Program Annual Energy Impacts from 2002 to 2011 ..... 4-25

Table 4-7: Program Administrator 2011 Energy Impacts ..... 4-27

Table 4-8: Program Administrator Mean Annual Capacity Factors ..... 4-27

Table 4-9: Investor-owned Utilities 2011 Peak Hour Demands ..... 4-28

Table 4-10: PG&E Peak Hour Demand Impacts ..... 4-28

Table 4-11: SCE Peak Demand Impacts ..... 4-29

Table 4-12: SDG&E Peak Demand Impacts ..... 4-29

Table 5-1: Required Minimum PUC 216.6 Levels of Performance ..... 5-4

Table 5-2: Program Level Heat and Fuel Impacts ..... 5-4

Table 5-3: End-uses Served by Recovered Useful Thermal Energy ..... 5-5

Table 5-4: PUC 216.6 CHP Project Performances by Technology ..... 5-5

Table 5-5: Electric Conversion Efficiencies—Metered Projects ..... 5-9

Table 5-6: Details of Heat Rate Recovery by Technology .....5-10

Table 5-7: CHP Project Overall Project Efficiency by Technology .....5-10

Table 5-8: Completed Projects by CARB NO<sub>x</sub> Standards .....5-13

Table 6-1: Baseline CO<sub>2</sub> Emission Components by Fuel Type .....6-4

Table 6-2: CO<sub>2</sub> Emission Impacts from Non-renewable Projects in 2011 .....6-6

Table 6-3: CO<sub>2</sub> Emission Rates for Non-renewable Projects in 2011.....6-7

Table 6-4: Biogas Baseline Assumption.....6-11

Table 6-5: CO<sub>2</sub> Emission Impacts from Biogas Projects in 2011 - Flared CH<sub>4</sub> Baseline .....6-12

Table 6-6: CO<sub>2</sub> (and CO<sub>2</sub>Eq) Emission Impacts from Biogas Projects in 2011 - Vented CH<sub>4</sub> Baseline.....6-12

Table 6-7: CO<sub>2</sub> Emission Rates from Biogas Projects in 2011 - Flared CH<sub>4</sub> Baseline .....6-13

Table 6-8: CO<sub>2</sub> (and CO<sub>2</sub>Eq) Emission Rates from Biogas Projects in 2011 – Vented CH<sub>4</sub> Baseline.....6-13

Table 6-9: CO<sub>2</sub> (and CO<sub>2</sub>Eq) Emission Impacts from All SGIP Projects in 2011...6-15

Table 6-10: CO<sub>2</sub> (and CO<sub>2</sub>Eq) Emission Impacts and Emission Rates from all SGIP Projects in 2011 by Type and Fuel .....6-16

Table 6-11: CO<sub>2</sub> (and CO<sub>2</sub>Eq) Emission Impacts from all SGIP Projects in 2011 by PA and Technology Type .....6-17

Table 6-12: CO<sub>2</sub> (and CO<sub>2</sub>Eq) Emission Impacts from all SGIP Projects in 2011 by PA and Fuel Type.....6-18

Table A-1: Annual Electric Energy Totals by Technology and PA..... A-3

Table A-2: 2011 Quarterly Electric Energy Totals ..... A-4

Table A-3: 2011 CAISO Peak Hour Demand Impacts..... A-5

Table A-4: 2011 CAISO Peak Hour Output by Technology, Fuel, and Basis—PG&E ..... A-7

Table A-5: 2011 CAISO Peak Hour Output by Technology, Fuel, and Basis—SCE..... A-8

Table A-6: 2011 CAISO Peak Hour Output by Technology, Fuel, and Basis—SDG&E..... A-9

Table A-7: 2011 IOU Peak Hours Demand Impacts—PG&E ..... A-12

Table A-8: 2011 IOU Peak Hours Demand Impacts—SCE ..... A-13

Table A-9: 2011 IOU Peak Hours Demand Impacts—SDG&E..... A-14

Table A-10: 2011 Annual Capacity Factors..... A-15

Table A-11: 2011 Annual Capacity Factors by Technology and PA..... A-15

Table A-12: 2011 Annual Capacity Factors by Technology and Fuel..... A-16

Table A-13: 2011 Annual Electric Energy Totals by PA ..... A-20

Table A-14: 2011 Quarterly Electric Energy Totals ..... A-20

Table A-15: 2011 CAISO Peak Hour Demand Impacts..... A-20

Table A-16: 2011 IOU Peak Hours Demand Impacts..... A-21

Table A-17: 2011 Annual Capacity Factors..... A-21

Table A-18: 2011 Annual Capacity Factors by PA ..... A-21

Table A-19: 2011 Annual Electric Energy Totals by Technology and PA..... A-26

Table A-20: 2011 Quarterly Electric Energy Totals by Technology ..... A-27

Table A-21: 2011 CAISO Peak Hour Demand Impacts by Technology ..... A-27

Table A-22: 2011 IOU Peak Hours Demand Impacts by Technology ..... A-28

Table A-23: 2011 Annual Capacity Factors by Technology..... A-28

Table A-24: 2011 Annual Capacity Factors by Technology and PA..... A-29

Table A-25: 2011 Annual Electric Energy Totals by PA ..... A-34

Table A-26: 2011 Quarterly Electric Energy Totals ..... A-34

Table A-27: 2011 CAISO Peak Hour Demand Impacts..... A-35

Table A-28: 2011 IOU Peak Hours Demand Impacts..... A-35

Table A-29: 2011 Annual Capacity Factors..... A-35

Table A-30: 2011 Annual Capacity Factors by PA ..... A-36

Table A-31: 2011 Annual Electric Energy Totals by PA ..... A-40

Table A-32: 2011 Quarterly Electric Energy Totals ..... A-40

Table A-33: 2011 CAISO Peak Hour Demand Impacts..... A-41

Table A-34: 2011 IOU Peak Hours Demand Impacts..... A-41

Table A-35: 2011 Annual Capacity Factors..... A-42

Table A-36: 2011 Annual Capacity Factors by Technology and PA..... A-42

Table B-1: GHG Emission Impacts for all PAs by Technology Type and Fuel  
(Metric Tons of CO<sub>2</sub> Equivalents)..... B-17

Table B-2: GHG Emission Impacts for all PAs by Technology Type and Fuel  
(Metric Tons of CO<sub>2</sub> Equivalents)—Continued ..... B-18

Table B-3: Emission Impact Factors for All PAs by Technology Type and Fuel  
(Tons of CO<sub>2</sub> equivalents per MWh)..... B-19

Table B-4: Emission Impact Factors for All PAs by Technology Type and Fuel (Tons of CO <sub>2</sub> equivalents per MWh)—Continued .....	B-20
Table B-5: Emission Impact Factors for All PAs by Technology Type and Fuel (Tons of CO <sub>2</sub> equivalents per MWh)—Continued .....	B-21
Table C-1: CH <sub>4</sub> Disposition Baseline Assumptions for Biogas Projects .....	C-9
Table C-2: Summary of Random Measurement-Error Variables .....	C-12
Table C-3: Performance Distributions Developed for the 2010 CAISO Peak Hour MCS Analysis.....	C-16
Table C-4: Performance Distributions Developed for the 2010 Annual Energy Production MCS Analysis.....	C-16
Table C-5: Uncertainty Analysis Results for Annual Energy Impact Results by Technology and Basis .....	C-32
Table C-6: Uncertainty Analysis Results for Annual Energy Impact Results by Technology, Fuel, and Basis .....	C-33
Table C-7: Uncertainty Analysis Results for PG&E Annual Energy Impact.....	C-34
Table C-8: Uncertainty Analysis Results for SCE Annual Energy Impact.....	C-34
Table C-9: Uncertainty Analysis Results for SCG Annual Energy Impact .....	C-35
Table C-10: Uncertainty Analysis Results for CCSE Annual Energy Impact .....	C-35
Table C-11: Uncertainty Analysis Results for Peak Demand Impact.....	C-36
Table C-12: Uncertainty Analysis Results for Peak Demand Impact Results by Technology, Fuel, and Basis for PG&E .....	C-37
Table C-13: Uncertainty Analysis Results for Peak Demand Impact Results by Technology, Fuel, and Basis for SCE .....	C-38
Table C-14: Uncertainty Analysis Results for Peak Demand Impact Results by Technology, Fuel, and Basis for SCG .....	C-39
Table C-15: Uncertainty Analysis Results for Peak Demand Impact Results by Technology, Fuel, and Basis for CCSE .....	C-40
Table C-16: Uncertainty Analysis Results for Annual PUC 216.6(b) .....	C-41
Table D-1: Cumulative System Cost and Incentive Trends .....	D-2
Table D-2: Renewable and Non-Renewable Cumulative System Cost and Incentive Trends.....	D-3

# 1

## Executive Summary

---

### Abstract

This report provides an evaluation of the impacts of the Self-Generation Incentive Program (SGIP) at the end of its eleventh year of operation. The SGIP is unique in several ways. As an 11-year old program, it is the longest-lived distributed generation (DG) incentive program in the United States. Although the SGIP supplies incentives to numerous DG technologies, it represents a greater number and rebated capacity of combined heat and power (CHP) projects than any other CHP incentive program in the country. SGIP is also unique in that it has consistently placed invaluable cost and metered performance data on DG and CHP technologies in the public domain for over ten years.

Starting in 2011, the SGIP required projects achieve specific targets for reducing greenhouse gas (GHG) emissions to help mitigate global climate change. At the same time, SGIP projects have continued to address critical peak electricity demands. Based on a re-examination by the California Public Utilities Commission (CPUC) of the eligibility of SGIP technologies, 2011 saw the re-emergence of a wider variety of combined heat and power (CHP) technologies into the program. In many cases, these CHP technologies reflect improvements in performance, costs, and emissions controls.

By the end of 2011, nearly \$300 million in incentives had been provided to SGIP projects. SGIP incentives were matched by approximately \$700 million in other public and private funds, bringing total project investment to nearly \$1 billion. Over 540 SGIP projects have been deployed, contributing over 250 MW of rebated generating capacity to the state's electricity mix. During 2011, SGIP projects supplied over 760 Gigawatt-hours of electricity to California's grid; enough electricity to meet the needs of over 116,340 homes for one year. SGIP projects also supplied 105 MW of needed generating capacity to the grid during the height of California's summer 2011 peak demand. SGIP's combined heat and power (CHP) projects recovered nearly 1.4 trillion Btu's of waste heat during 2011 and used it to meet customer heating and cooling needs. There were mixed results on the ability of SGIP projects to meet efficiency requirements. Internal combustion (IC) engines and fuel cells were able to meet a 42.5% combined electrical/thermal efficiency requirement. However, microturbines and gas turbines fell short of meeting the requirement. Similarly, all of the SGIP CHP projects had problems meeting the 60% system efficiency requirement of AB 1680. Going forward, CHP projects can increase overall system efficiencies and improve GHG emission reductions by increasing recovery of useful waste heat. Overall, the SGIP successfully achieved its greenhouse gas (GHG) emission reduction goal; reducing over 46,000 metric tons of CO<sub>2</sub> equivalent GHG emissions during 2011. For non-renewable fueled CHP projects, GHG emission reductions were tied closely to increased recovery of useful waste heat. Renewable fueled projects were the greatest source of GHG emission reductions



for the SGIP. Significant reductions in GHG emissions in the future can be achieved if the SGIP successfully deploys renewable fuel projects at biogas sites that would have otherwise have vented methane directly to the atmosphere.

## **1.1 Conclusions & Recommendations**

The SGIP has operated for eleven years, producing significant benefits for California ratepayers, the California environment and the DG community. Recent changes in the SGIP are reshaping the program to achieve greater amounts and enhanced levels of benefits. Based on a blend of Itron's knowledge of DG and CHP technologies and over ten years of metered SGIP project performance data, we provide the following overall conclusions and recommendations:

1. Programs need clear goals and objectives. Goals and objectives enable the success of the program to be measured and assessed. In addition, interim milestones allow progress toward goals or objectives to be assessed and corrective measures taken to help ensure success. The SGIP currently only has quantitative goals for GHG emission reductions. The CPUC and PAs should consider adopting quantitative goals and objectives that build off of the eight guiding principles of the SGIP.<sup>1</sup>
2. The SGIP consists of a blend of new and older DG projects. There is clear evidence that as projects age, there is an increasing percentage that retire and is decommissioned. Aging projects may also provide less output than expected from their rebated generating capacity. The result is a lower than anticipated level of program benefits including electric energy and demand impacts, as well as reductions in GHG emissions. Because all projects age, the CPUC and PAs should explicitly plan for the effect of older projects on future impacts and the ability of the SGIP to hit desired future goals and objectives.
3. A primary goal of the SGIP is to reduce GHG emissions. The SGIP achieved net GHG emission reductions in 2011 primarily due to the large amount of renewable fueled projects. Future and significant GHG emissions reductions are possible and can be achieved through careful pursuit of a mix of strategies. We recommend the following three strategies to help achieve enhanced reductions in GHG emissions:
  - a. For electric-only technologies, ensure that electrical efficiencies are high enough to exceed the efficiencies of off-peak grid generation on a continuing basis (generally, this will require electrical conversion efficiencies in excess of 45%<sub>LHV</sub>).
  - b. For non-renewable CHP technologies, ensure these projects are designed for and achieve high useful heat recovery rates and at least modest electrical conversion efficiencies on an on-going basis. Appropriate levels of useful heat recovery rates and electrical conversion efficiencies are discussed in this impact report. In addition, the

---

<sup>1</sup> The eight guiding principles of the SGIP are contained in the Final Decision Modifying the SGIP. [http://docs.cpuc.ca.gov/published/Final\\_decision/143459-03.htm](http://docs.cpuc.ca.gov/published/Final_decision/143459-03.htm)

2010 SGIP Impact Report contained a GHG Nomograph that may be helpful in establishing appropriate useful heat recovery rates.<sup>2</sup>

- c. Seek adoption of renewable-fueled projects that offset the flaring or venting of methane where feasible.
4. The CPUC and PAs should consider ways to ensure SGIP CHP projects achieve high levels of useful heat recovery on an on-going basis. As noted above, high heat recovery rates are essential to achieving the GHG emission goals of the program. High useful heat recovery rates can also increase the economic feasibility of the project. In addition, increasing useful waste heat recovery could allow projects to better meet energy efficiency goals recently introduced into the program. At present, useful heat recovery rates are only examined when CHP projects apply to the SGIP. In particular, useful heat recovery rates are contained in the waste heat utilization workbook which is reviewed when the project applies for an SGIP incentive. However, there is no “true up” of the useful heat recovery rates after the project receives the incentive.<sup>3</sup> Thermal energy loads may have changed in the interim. Appropriate sampling of projects to assess the useful heat recovery rate and how well it matches the values assumed in the application can help identify possible problems and enable corrective action.
5. The SGIP was originally designed as a peak demand reduction program. The SGIP continues to provide peak demand benefits. However, as indicated in this impact report, some projects appear to be relatively insensitive to peak demand. The CPUC and PAs should consider developing specific targets or goals for peak demand reductions. This may be especially appropriate given the wider emergence of advanced energy storage technologies into the SGIP. Peak demand reductions tailored to utility-specific needs may be particularly beneficial in helping SGIP projects to address peak demand and reduce distribution feeder loading.

---

<sup>2</sup> See “CPUC Self-Generation Incentive Program: Tenth-Year Impact Evaluation,” Itron, July 7, 2011

<sup>3</sup> Under the hybrid PBI structure, GHG emission rates are examined on a yearly basis but there is no mechanism for “trueing up” the assumptions behind the useful heat recovery aspects of the GHG emission rates.

## 1.2 Introduction & Background

### **Key Take-Aways**

This impact report provides an Executive Summary that is a concise listing of the key facts presented in the report. Each page includes tables or figures followed by a limited number of “Key Take-Away” bullet points. The Executive Summary is, in essence, a deck of snapshots of key report topics. The report also uses hyperlinks to more easily allow readers to quickly find additional information on a topic presented in the Executive Summary. Hyperlinks, indicated by [blue underlined text](#), are used for ease of finding related sections in the body of the report or to related websites for such items as legislation and regulatory proceedings. For those reading a print copy, a “hard-copy link” to the main related report section is included immediately after the page heading, indicating the relevant section (e.g., *see Section 4*). While it is our intent that the Executive Summary provide a solid overview of evaluation findings, we strongly encourage reading the detail behind the graphics and “Key Take-Aways” to ensure they are not taken or used out of context. For further ease of use, a summary of topics covered in the Executive Summary and Key Terms used in the report are shown below.

<b>Executive Summary Topics</b>	
<a href="#">1.1 Conclusions &amp; Recommendations</a>	<a href="#">1.5 Peak Demand Impacts</a>
<a href="#">1.2 Introduction &amp; Background</a>	<a href="#">1.6 Efficiency &amp; Waste Heat Utilization</a>
<a href="#">1.3 Program-Status</a>	<a href="#">1.7 Greenhouse Gas Emission Reduction Impacts</a>
<a href="#">1.4 Electric Energy Impacts</a>	

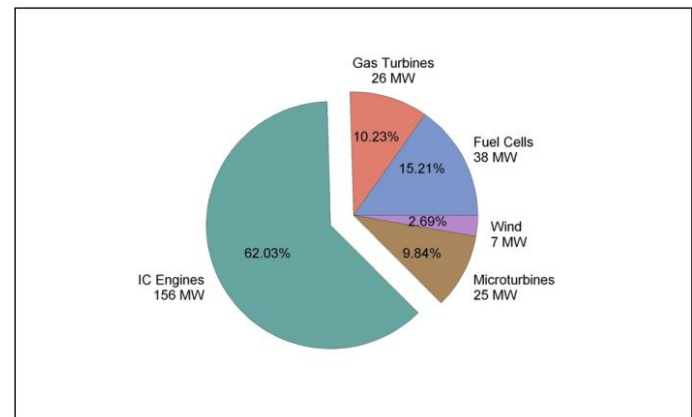
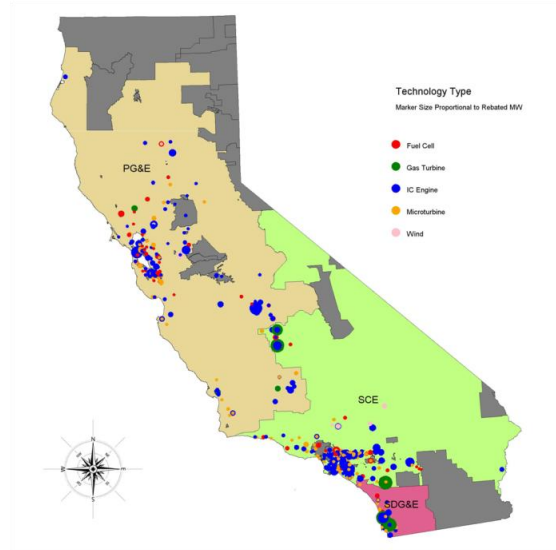
**Table 1-1: Key Terms in SGIP 2011 Evaluation Report**

<b>SGIP Project Categories</b>	
Active	Projects that have not been withdrawn, rejected, completed, or placed on a wait list. Active projects will eventually migrate either to the Complete or Inactive category.
Complete	Projects where the generation or storage system has been installed, verified through on-site inspections, and an incentive check has been issued.
Decommissioned	Decommissioned projects are ones where the SGIP equipment has been removed from the project site.
Inactive	No longer progressing in SGIP implementation process because they have been withdrawn by applicant or rejected by PA.
On-line	Projects that have entered normal operations but may be only operational for a limited time during 2011
Rebated Capacity	The capacity rating associated with the rebate (incentive) provided to the applicant. The rebate capacity may be lower than the typical “nameplate” rating of a generator.
<b>Technologies</b>	
AES	Advanced Energy Storage
CHP	Combined Heat and Power (used interchangeably with “cogeneration”)
DG	Distributed Generation
FC-N	Fuel Cells (Non-renewable)
FC-R	Fuel Cells (Renewable)
GT-N	Gas Turbines (Non-renewable-fueled)
GT-R	Gas Turbines (Renewable-fueled)
IC Engine-N	Internal Combustion Engines (Non-renewable-fueled)
IC Engine-R	Internal Combustion Engines (Renewable-fueled)
MT-N	Microturbines (Non-renewable-fueled)
MT-R	Microturbines (Renewable-fueled)
PV	Photovoltaics
WD	Wind Turbines
<b>Misc. Defined Terms</b>	
CCSE	California Center for Sustainable Energy (Formerly San Diego Regional Energy Office)
CEC	California Energy Commission
CPUC	California Public Utilities Commission
IOU	Investor-Owned Utility
PA	Program Administrator
PG&E	Pacific Gas and Electric Company
PY	Program Year
SCG	Southern California Gas Company
SDG&E	San Diego Gas and Electric Company
SCE	Southern California Edison

### 1.3 Program-Status (refer to Section 3)

#### Key Take-Aways:

- **Program Makeup:**
  - By the end of 2011, the SGIP is one of the longest lived and largest DG incentive programs in the county
  - SGIP’s 544 projects represent over 252 MW of rebated capacity and are located throughout the state; with heavier concentrations in urban areas
  - DG technologies deployed in the SGIP include fossil and renewable fueled IC engines, fuel cells, gas turbine and microturbines; wind and advanced energy storage
  - At 203 MW, non-renewable projects provided over 80% of the total rebated SGIP capacity
  - IC engines (non-renewable and renewable) provided 62% of total rebated capacity (156 MW)
- **Incentives Paid:**
  - At the end of 2011, over \$298 million in incentives had been paid to SGIP projects
  - Total cumulative eligible projects costs were approximately \$1 billion; with \$700 million in out-of-pocket costs.
  - SGIP funds were leveraged at \$2.35 of other funds to every \$1 in SGIP incentives
  - \$135 million in incentives were paid to renewable projects vs. \$163 million for non-renewable projects



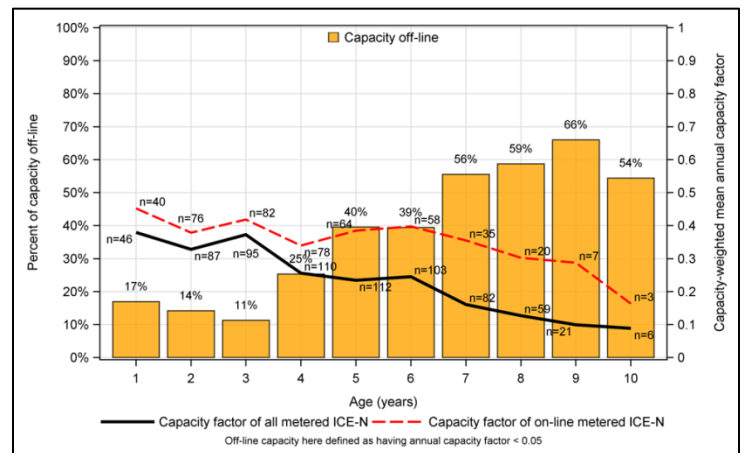
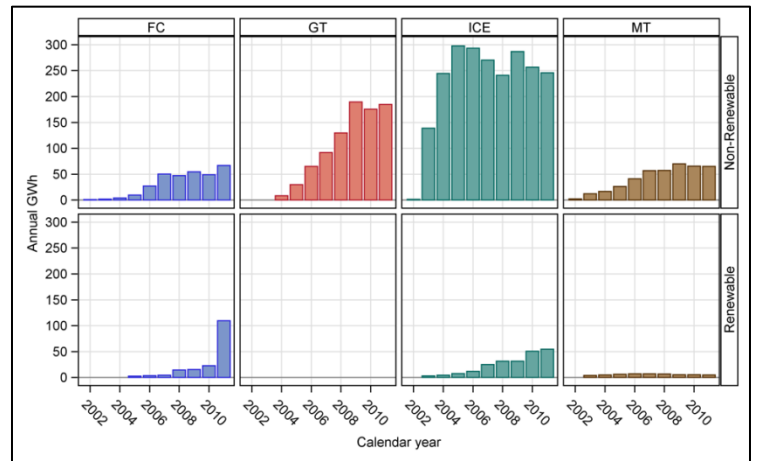
Technology	Paid		
	Rebated Capacity (M W )	Wt.Avg. \$/W	Total (\$ M M )
Fuel Cells	38	\$3.79	\$145
IC Engines	156	\$0.72	\$112
Microturbines	25	\$1.03	\$26
Wind	7	\$1.18	\$8
Gas Turbines	26	\$0.26	\$7
Overall	252	\$1.18	\$298

## 1.4 Electric Energy Impacts [\(refer to Section 4\)](#)

### Key Take-Aways

- **Annual Energy:**
  - During 2011, SGIP projects delivered 760 Gigawatt-hours (GWh) of electricity; enough electricity to meet the demand of over 116,340 homes for one year
  - Non-renewable projects supplied nearly 77% of the electricity delivered by the SGIP in 2011
  - IC engines (both renewable and non-renewable) provided nearly 42% of the overall delivered electricity
  - [IC engines](#) have historically contributed the greatest share of annual energy. Since 2010, fuel cells are contributing an increasing amount of the annual energy
- **Performance Metrics and Trends:**
  - For most program technologies, mean ages of capacity have been steadily increasing, contributing to increased percentages of retired capacity, declines in capacity utilization, and relative declines in their program impacts
  - Gas turbines had the highest annual capacity factor at 0.83 kW of power for each kW of rebated capacity
  - Annual and [CAISO peak hour](#) utilizations of IC engine capacity have fallen with increasing mean capacity age

Technology	Fuel	Q1-2011 (GWh)	Q2-2011 (GWh)	Q3-2011 (GWh)	Q4-2011 (GWh)	Total* (GWh)
FC	N	14	17	19	18	68
	R	21	26	31	31	110
GT	N	44	47	47	50	187
	R	11	16	18	18	62
ICE	N	57	61	78	62	257
	R	11	16	18	18	62
MT	N	14	19	18	20	71
	R	1.2	0.9	1.4	1.4	5
TOTAL	N	128	143	162	150	583
	R	33	43	50	51	177
TOTAL		161	186	211	201	760

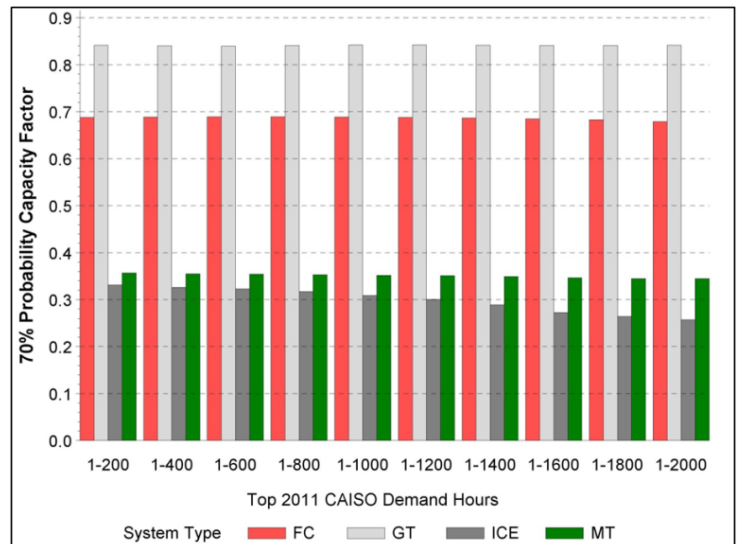
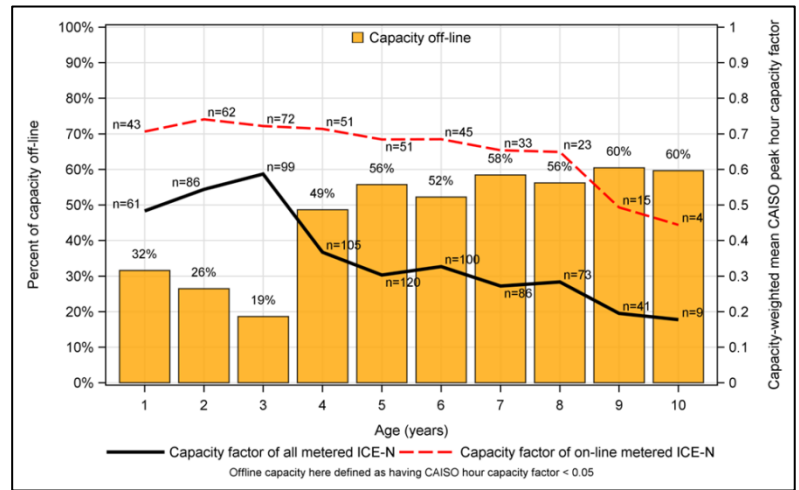


## 1.5 Peak Demand Impacts [\(refer to Section 4\)](#)

### Key Take-Aways:

- **CAISO Summer Peak:**
  - SGIP projects provided 105 MW of capacity during the 2011 CAISO summer peak
  - In aggregate, SGIP projects provided 0.44 kW of generating capacity for each kW of rebated capacity during the 2011 CAISO peak
  - Gas turbines and fuel cells had the highest CAISO peak hour capacity factors at 0.83 and 0.70 kW of generating capacity for each kW of rebated capacity, respectively
  - CAISO peak hour utilizations of [IC engine capacities](#) have fallen with increasing mean capacity age, falling sharply at age 4
- **Top 2000 CAISO Demand Hours:**
  - SGIP’s CHP projects are relatively insensitive to CAISO demand
  - Gas turbines demonstrate hourly capacity factors above 0.8 while fuel cells show hourly capacity factors close to 0.7 kW per kW of rebated capacity across the top 2000 hours of CAISO demand

Type	Count (n)	Capacity* (MW)	Impact* (MW)	Capacity factor (kWh/kWh)
FC	113	32	23	0.70
GT	8	26	21	0.83
ICE	254	156	53	0.34
MT	140	25	9	0.35
<b>Total</b>	<b>515</b>	<b>238</b>	<b>105</b>	<b>0.44</b>



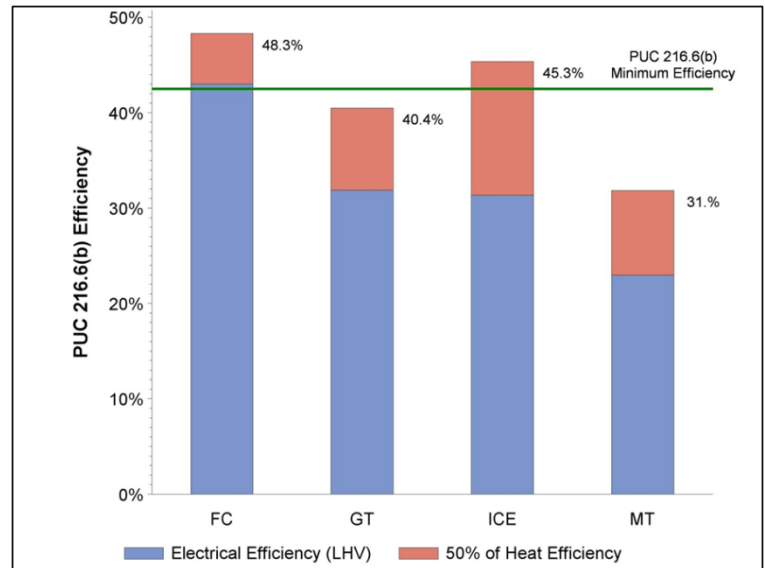
## 1.6 Efficiency and Waste Heat Utilization [\(refer to Section 5\)](#)

### Key Take-Aways:

- **Fuel Consumed and Heat Recovered:**
  - SGIP projects consumed nearly 7 trillion Btu’s of fuel during 2011 and recovered close to 1.4 trillion Btu’s (or 20% of the energy consumed as fuel) to help meet on-site energy needs
  - Over 300 SGIP projects recovered waste heat to help meet on-site heating needs; another 83 recovered waste heat to help meet on-site heating and cooling needs
- **Useful Heat Recovery Requirements:**
  - PUC 216.6(a) requires recovered useful heat from CHP systems to exceed 5% of combined recovered heat plus the electrical energy output of the system
  - All CHP technologies in the SGIP exceeded this requirement
- **Efficiency Requirements:**
  - PUC 216.6(b) requires the sum of electricity generated and half of the recovered heat by CHP systems to exceed 42.5% of energy entering the system as fuel
  - FC and IC engines were able to achieve the PUC 216.6(b) requirement, while GT and MT fell short of the requirement
- **60% System Efficiency Requirement:**
  - AB 1685 requires combustion-based CHP technologies in the SGIP to achieve a 60% system efficiency on a higher heating basis
  - None of the CHP technologies achieved the 60% threshold; IC engines at 53.6% came the closest

Technology Type	Estimated Useful Heat Recovered (Billion Btu)	Estimated Fuel Consumed (Billion Btu) <sub>LHV</sub>	Useful Heat Energy as Percentage of Electrical Energy
FC	43	1,035	7%
GT	346	2,006	54%
ICE	776	2,834	71%
MT	192	1,066	74%
<b>Total</b>	<b>1,358</b>	<b>6,942</b>	<b>52%</b>

End Use Application	Completed Projects (n)	Completed Capacity (kW)
Cooling Only	39	33,811
Heating & Cooling	83	62,960
Heating Only	309	104,654
To Be Determined	2	360
<b>Total</b>	<b>433</b>	<b>201,785</b>

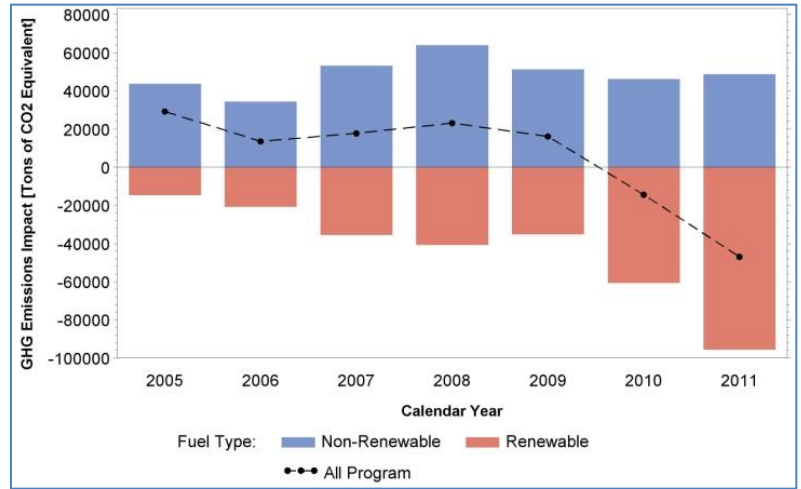




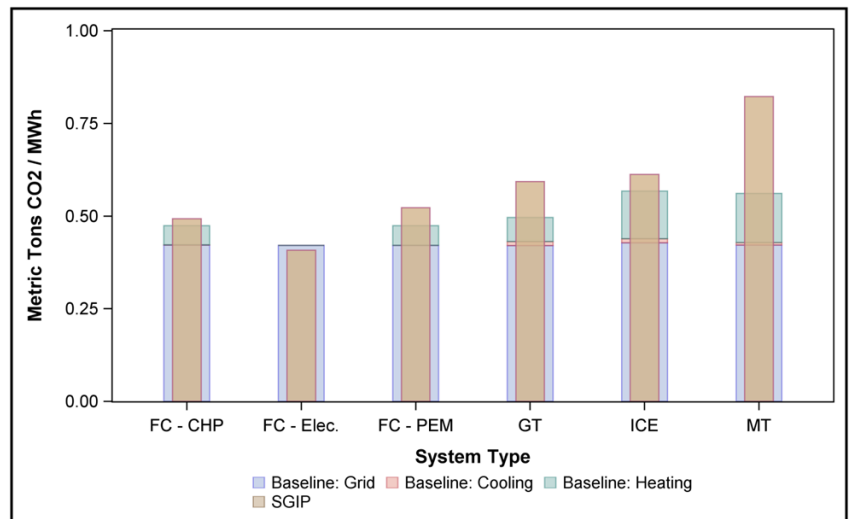
## 1.7 Greenhouse Gas Emission Reduction Impacts [\(refer to Section 6\)](#)

### Key Take-Aways:

- **GHG Goals:**
  - The SGIP has shown steady reductions in GHG emissions since 2008 and was a net GHG reducing program starting in 2010
  - At the end of calendar year 2011, the SGIP reduced GHG emissions by over [46,000](#) metric tons per year (as CO<sub>2</sub> equivalent)
- **Sources of GHG Emissions:**
  - Non-renewable projects increased net GHG emissions by over 48,000 metric tons per year
  - Renewable fueled projects that would have otherwise [flared](#) captured methane were the greatest source of net GHG emission reductions, reducing GHG emissions by nearly 66,000 metric tons per year
  - Renewable fueled IC engine projects that would have otherwise [vented methane](#) directly into the atmosphere represented the single largest source of GHG emission rate reductions (4.5 metric tons of CO<sub>2</sub> equivalent per MWh) and reduced GHG emissions by over 29,000 metric tons per year



Type	SGIP CO <sub>2</sub> Emissions (Metric Tons of CO <sub>2</sub> per Year) A	Baseline Emissions (Metric Tons of CO <sub>2</sub> per Year)					Total Baseline Emissions F=B+C+D+E	GHG Emissions Impact (Metric Tons of CO <sub>2</sub> per Year) G=A-F
		Electric Power Plant Emissions B	Heating Services C	Cooling Services D	CO <sub>2</sub> Emissions from Biogas Treatment E			
FC	78,949	74,669	2,554	32	39,084	116,339	-37,390	
GT	111,071	78,780	12,218	2,002	0	93,000	18,071	
ICE	195,234	136,066	35,237	2,861	64,980	239,144	-43,910	
MT	62,512	32,038	9,545	529	4,064	46,176	16,336	
<b>Total</b>	<b>447,766</b>	<b>321,553</b>	<b>59,553</b>	<b>5,425</b>	<b>108,128</b>	<b>494,659</b>	<b>-46,893</b>	



# 2

## Introduction

---

### 2.1 Program Background

The Self-Generation Incentive Program (SGIP) represents one of the largest and longest-lived incentive programs for distributed generation (DG) and combined heat and power (CHP) technologies in the country. The SGIP was originally established in 2001 to help address peak electricity demand problems confronting California. Over time, the SGIP has evolved in response to changes in California’s electricity system, establishment of new energy policies and the emergence of new and innovative energy technologies.

Since its inception, the SGIP has provided incentives to a wide variety of DG and CHP technologies. Technologies receiving SGIP incentives have included solar photovoltaic (PV) systems, wind turbines, fossil- and renewable-fueled internal combustion (IC) engines, fuel cells, microturbines, small-scale gas turbines, and more recently, advanced energy storage systems.

The SGIP was initiated in 2001 as a peak demand reduction program.<sup>1</sup> It also represented a way to help utilities and stakeholders assess the performance and costs of DG and CHP technologies in real world settings. As proposed, the SGIP did not originally set goals for the capacity of DG to be installed under the program or the amount of electricity to be delivered by the projects. Similarly, SGIP projects were intended only to offset electricity demand incurred at the utility customer site. Projects were not expected or allowed to export electricity into the grid. While the SGIP lacked quantitative program goals, the program contained a variety of measures to help ensure SGIP projects performed as expected. For example, SGIP projects were required to meet minimum specified electrical and waste heat recovery efficiencies. In addition, maintenance warranties ranging from three to five years were required on all installed DG and CHP equipment to make sure systems remained in good working condition.

As noted above, the portfolio of SGIP projects has changed over time, reflecting different policies and new technologies. The early “fleet” of DG and CHP technologies deployed through the SGIP consisted primarily of IC engines, the then emerging microturbine systems, some small

---

<sup>1</sup> The SGIP was enacted as part of Assembly Bill 920 (California Energy Security and Reliability Act of 2000) (Ducheny, September 6, 2000). [http://www.leginfo.ca.gov/pub/99-00/bill/asm/ab\\_0951-1000/ab\\_970\\_bill\\_20000907\\_chaptered.html](http://www.leginfo.ca.gov/pub/99-00/bill/asm/ab_0951-1000/ab_970_bill_20000907_chaptered.html)

gas turbines and fuel cells and a promising generation of PV systems. By 2006, the energy landscape had changed dramatically. There was intense interest by the Governor and Legislature in increased deployment of PV technologies. Enacted in August of 2006, Senate Bill 1 (SB1) created the California Solar Initiative (CSI). The CSI targeted a significant growth in new solar generation and transformation of the California solar market. The CSI replaced the SGIP as a PV incentive vehicle. Effective January 1, 2007, PV technologies were no longer eligible to receive SGIP incentives.<sup>2</sup>

Other significant changes affected the CHP component of the SGIP fleet from 2007 through 2009. Growing concerns with potential air quality impacts prompted changes to the eligibility of DG and CHP technologies.<sup>3</sup> In particular, approval of AB 2778<sup>4</sup> in September 2006 limited SGIP project eligibility to “ultra-clean and low emission distributed generation” technologies.<sup>5</sup> Beginning January 1, 2007, only fuel cells and wind turbines were eligible for the SGIP.

Advanced energy storage (AES) technologies (used in conjunction with wind turbines or fuel cells) were added to the list of eligible SGIP technologies in November 2008.<sup>6</sup> In September of 2009, “directed” biogas technologies<sup>7</sup> were made eligible to the SGIP by CPUC Decision 09-09-048.<sup>8</sup>

Passage of Senate Bill 42<sup>9</sup> in 2009 refocused the SGIP toward greenhouse gas (GHG) emission reductions and led to a re-examination of CHP eligibility by the California Public Utilities Commission (CPUC). As a result of that re-examination, the list of technologies eligible for the SGIP has expanded. Beginning in October 2011, technologies eligible to apply for SGIP incentives include wind turbines; organic Rankine cycle/waste heat capture systems; pressure reduction turbines; advanced energy storage systems; fuel cells; combined heat and power gas turbines; micro-turbines; and internal combustion engines.

---

<sup>2</sup> Information on the CSI, including impacts, performance and cost aspects can be found at the Go Solar California website: <http://www.gosolarcalifornia.org/csi/index.php>

<sup>3</sup> Details on the CARB DG certification program and rulings can be found at: <http://www.arb.ca.gov/energy/dg/dg.htm>

<sup>4</sup> AB 2778 (Lieber, September 29, 2006). [http://www.leginfo.ca.gov/pub/05-06/bill/asm/ab\\_2751-2800/ab\\_2778\\_bill\\_20060929\\_chaptered.html](http://www.leginfo.ca.gov/pub/05-06/bill/asm/ab_2751-2800/ab_2778_bill_20060929_chaptered.html)

<sup>5</sup> These were defined as technologies that met or exceeded emissions standards required under a DG certification program adopted by the California Air Resources Board (CARB)

<sup>6</sup> CPUC D.08.011.044, November 21, 2008. [http://docs.cpuc.ca.gov/PUBLISHED/FINAL\\_DECISION/94272.htm](http://docs.cpuc.ca.gov/PUBLISHED/FINAL_DECISION/94272.htm)

<sup>7</sup> Directed biogas is biogas collected from landfills, wastewater treatment facilities or dairies located outside the SGIP host site, and delivered into the utility natural gas pipeline system. SGIP facilities can procure quantities of “nominated” biogas for use as a renewable fuel, although none of the biogas is required to be physically delivered to the SGIP site.

<sup>8</sup> CPUC D.09.09.048, September 24, 2009. [http://docs.cpuc.ca.gov/PUBLISHED/FINAL\\_DECISION/107574.htm](http://docs.cpuc.ca.gov/PUBLISHED/FINAL_DECISION/107574.htm)

<sup>9</sup> Senate Bill 412 (Kehoe 2009): [http://www.leginfo.ca.gov/pub/09-10/bill/sen/sb\\_0401-0450/sb\\_412\\_bill\\_20091011\\_chaptered.pdf](http://www.leginfo.ca.gov/pub/09-10/bill/sen/sb_0401-0450/sb_412_bill_20091011_chaptered.pdf)

## **2.2 Recent Changes in the SGIP Handbook**

Changes in the portfolio of projects influence program impacts and trends. The degree to which these new projects affect the ability of the SGIP to achieve GHG emission reductions or other program goals is dependent on the objectives set for the projects and the success of their implementation. The SGIP Handbook sets out specific guidelines on project goals and targets to be achieved by SGIP projects when being implemented. Several significant changes occurred in the 2011 handbook that may affect program impacts, including the following:

- Eligibility of CHP technologies has been set in accordance with GHG emission reductions.
  - Non-renewable CHP project eligibility is determined on a case by case basis.
  - Electric only technologies using fossil fuels will need certification of performance based on a testing protocol.
  - The GHG baseline that determines eligibility is 349 kg of CO<sub>2</sub> (eq)/MWh (769 lb/MWh)
- Payment structure has been revised as a hybrid PBI where 50% of the incentive is paid upfront and the other 50% is paid as a PBI based on kWh generation of on-site load.
  - Projects under 30 kW will receive the entire incentive upfront.
  - Projects will be subject to a 5% band for GHG emission rate.
  - No penalty is assessed in any year that cumulative emissions rate does not exceed 398 kg CO<sub>2</sub>/MWh.
  - PBI payments will be reduced by half in years where a project's cumulative emission rate is greater than 398 kg CO<sub>2</sub>/MWh but less than or equal to 417 kg CO<sub>2</sub>/MWh.
  - Projects that exceed an emission rate of 417 kg CO<sub>2</sub>/MWh in any given year will receive no PBI payments for the year.
- The waste heat recovery worksheet, used for targeting and determining GHG emission reductions, was revamped to target coincidence of thermal and electrical loads.
  - A simplified residential fuel cell waste heat recovery worksheet was also created.
- AES eligibility: can be stand alone or paired with SGIP eligible or PV technologies, but must be able to discharge at its rated capacity for a minimum of 2 hours each day.
- Biogas eligibility: biogas must be on-site or, if directed biogas, from in-state sources.
  - Directed biogas contracts have a minimum 10-year term and must demonstrate that the directed biogas provides a minimum of 75% of the total energy input required each year.
- Export to grid is allowed: 25% maximum on an annual net basis.

## 2.3 Impact Evaluation Requirements

The original 2001 CPUC decision establishing the SGIP required “program evaluations and load impact studies to verify energy production and system peak demand reductions” resulting from the SGIP.<sup>10</sup> D.01-03-073 also directed the assigned Administrative Law Judge (ALJ), in consultation with the CPUC Energy Division and the PAs, to establish a schedule for filing the required evaluation reports. Ten annual impact evaluations have been conducted to date on the SGIP.<sup>11</sup>

Specific objectives of the impact evaluations have varied each year but generally include impacts on electrical energy production; peak demand; operating and reliability statistics; transmission and distribution system impacts; air pollution emission impacts; and compliance of SGIP projects with thermal energy utilization and system efficiency requirements.

In addition to being one of the largest and longest-lived DG incentive programs in the country, the SGIP also represents a program with an extremely diverse family of technologies. DG technologies deployed under the SGIP receive incentives in accordance with their associated “incentive level.” Because incentive levels and the groupings of technologies that fall within them have changed over time, impact results are summarized in this report by technology and fuel type instead of incentive level.<sup>12</sup>

Table 2-1 summarizes the SGIP technology groups used in this report.

**Table 2-1: SGIP Technologies and Applicable Program Years**

SGIP Generation Technology	Applicable Program Years
Photovoltaics (PV)	PY01–PY06
Wind turbines (WD)	PY01–PY11
Non-renewable fuel cells (FC-N)	PY01–PY11
Renewable fuel cells (FC-R)	PY01–PY11
Non-renewable-fueled internal combustion engines (IC Engine-N)	PY01–PY07
Renewable-fueled internal combustion engines (IC Engine-R)	PY01–PY07
Non-renewable-fueled microturbines (MT-N)	PY01–PY07
Renewable-fueled microturbines (MT-R)	PY01–PY07
Non-renewable-fueled gas turbines (GT-N)	PY01–PY07
Renewable-fueled gas turbines (GT-R)	PY01–PY07
Advanced energy storage (AES)	PY08–PY11

<sup>10</sup> CPUC D.01-03-073, March 27, 2001, page 37.

<sup>11</sup> A listing of past SGIP impact reports can be found and downloaded at the following CPUC web site: <http://www.cpuc.ca.gov/PUC/energy/DistGen/sgip/sgipreports.htm>

<sup>12</sup> The use of technology and fuel type in lieu of incentive level was initiated with the Sixth Year Impact Report.

## **2.4 Scope of this Report**

### **2.4.1 Impact Evaluation Objectives**

The 2011 Impact Evaluation Report represents the eleventh impact evaluation conducted for the SGIP. At the most fundamental level, the overall purpose of all annual SGIP impact evaluation analyses is identical: to produce information that helps policy makers and SGIP stakeholders make informed decisions about the SGIP’s design and implementation.

The 2011 SGIP Impact Evaluation Report examines impacts at both the program-wide and utility-specific levels on electrical energy production; coincident peak demand; operating and reliability characteristics; air pollution and greenhouse gas emission (GHG) impacts; and compliance of SGIP projects with thermal energy utilization and system efficiency requirements. Transmission and distribution system impacts are not examined in this impacts evaluation report as they were investigated in the 2010 topical report, “Optimizing Dispatch and Location of Distributed Generation.”<sup>13</sup>

Specific impact evaluation objectives for the 2011 evaluation include:

- Electricity energy production and demand reduction:
  - Annual energy production (both program-wide and at individual PA levels) and further broken down by SGIP technology and fuel type
  - Peak demand impacts (both at CAISO system and at individual IOU-specific summer peaks) and further broken down by SGIP technology and fuel type (where possible)
  - Overall generation performance as indicated by annual capacity factor and peak hour capacity factor
- Assessing compliance of fuel cell, internal combustion (IC) engine, microturbine, and gas turbine technologies against PUC 216.6<sup>14</sup> requirements
  - PUC 216.6 (a): useful recovered waste heat requirements
  - PUC 216.6 (b): system efficiency requirements
- Estimating GHG emission reductions by SGIP technology

---

<sup>13</sup> Itron, Inc. and BEW Engineering, *California Self-Generation Incentive Program: Optimizing Dispatch and Location of Distributed Generation*. Submitted to Pacific Gas & Electric, July 2010.  
[https://www.itron.com/na/PublishedContent/SGIP\\_Optimizing\\_DG\\_Dispatch\\_Location.pdf](https://www.itron.com/na/PublishedContent/SGIP_Optimizing_DG_Dispatch_Location.pdf)

<sup>14</sup> Public Utilities Code 216.6 was previously Public Utilities Code 218.5. The requirements have not changed.  
<http://www.leginfo.ca.gov/cgi-bin/displaycode?section=puc&group=00001-01000&file=201-248>

- Net CO<sub>2</sub> emissions generated from SGIP projects relative to a baseline of power and energy supplied by the grid (i.e., the baseline represents operation of the host site in absence of the SGIP project)
- Methane captured by renewable fuel use projects and CO<sub>2</sub> emissions from flaring of captured biogas is avoided (by routing the captured biogas into the SGIP generator)
- Trending of performance by SGIP technology from 2002 through 2011

## **2.5 Report Organization**

This report is organized into six sections and four appendices, as described below.

- **Section 1** provides an executive summary of the key objectives and findings of this eleventh-year impact evaluation of the SGIP through the end of 2011.
- **Section 2** is this introduction.
- **Section 3** presents a summary of the program status of the SGIP through the end of 2011.
- **Section 4** discusses the 2011 impacts associated with energy delivery and peak demand reduction at the program and PA levels.
- **Section 5** discusses the 2011 impacts associated with fuel use and heat recovery at the program and PA levels. This section specifically examines compliance of SGIP technologies with program requirements related to efficiency.
- **Section 6** presents results of an analysis of the GHG emissions from SGIP technologies and the performance of the SGIP in reducing GHG emissions.
- **Appendix A** provides more detailed information on annual energy produced, peak demand, and capacity factors by technology and fuel type.
- **Appendix B** describes the methodology used for developing estimates of SGIP GHG impacts.
- **Appendix C** describes the data collection and processing methodology, including the uncertainty analysis of the program-level impacts. This appendix also contains the performance distributions used in the uncertainty analysis.
- **Appendix D** provides information on system costs and trends.

# 3

## Program Status

---

### 3.1 Introduction

This section provides information on the status of the SGIP as of December 31, 2011. The status is based on project data provided by the PAs relative to all applications extending from Program Year 2001 (PY01) through the end of Program Year 2011 (PY11). The program status does not include photovoltaic (PV) systems which prior to 2007 had been eligible to receive incentives under the SGIP.<sup>1</sup> Information in this section includes the geographical distribution of SGIP projects, background information on trends within the SGIP, the technology and fuel type characteristics of SGIP projects, the financial and cost characteristics of projects, and characteristics of projects by Program Administrator (PA). Information on wind projects has been included in this section to provide complete accounting of SGIP capacities. However, due to limited metered data, impacts from wind projects are not presented in the analysis sections of the report.<sup>2</sup>

### 3.2 Geographical Distribution

Geographically, projects deployed under the SGIP are located throughout the service territories of the major investor-owned utilities (IOUs) in California and across a number of municipal electric utilities. Figure 3-1 shows the distribution of SGIP projects by technology type across IOU electric service territories of California. As may be expected, SGIP projects tend to be concentrated in the urban centers of California.

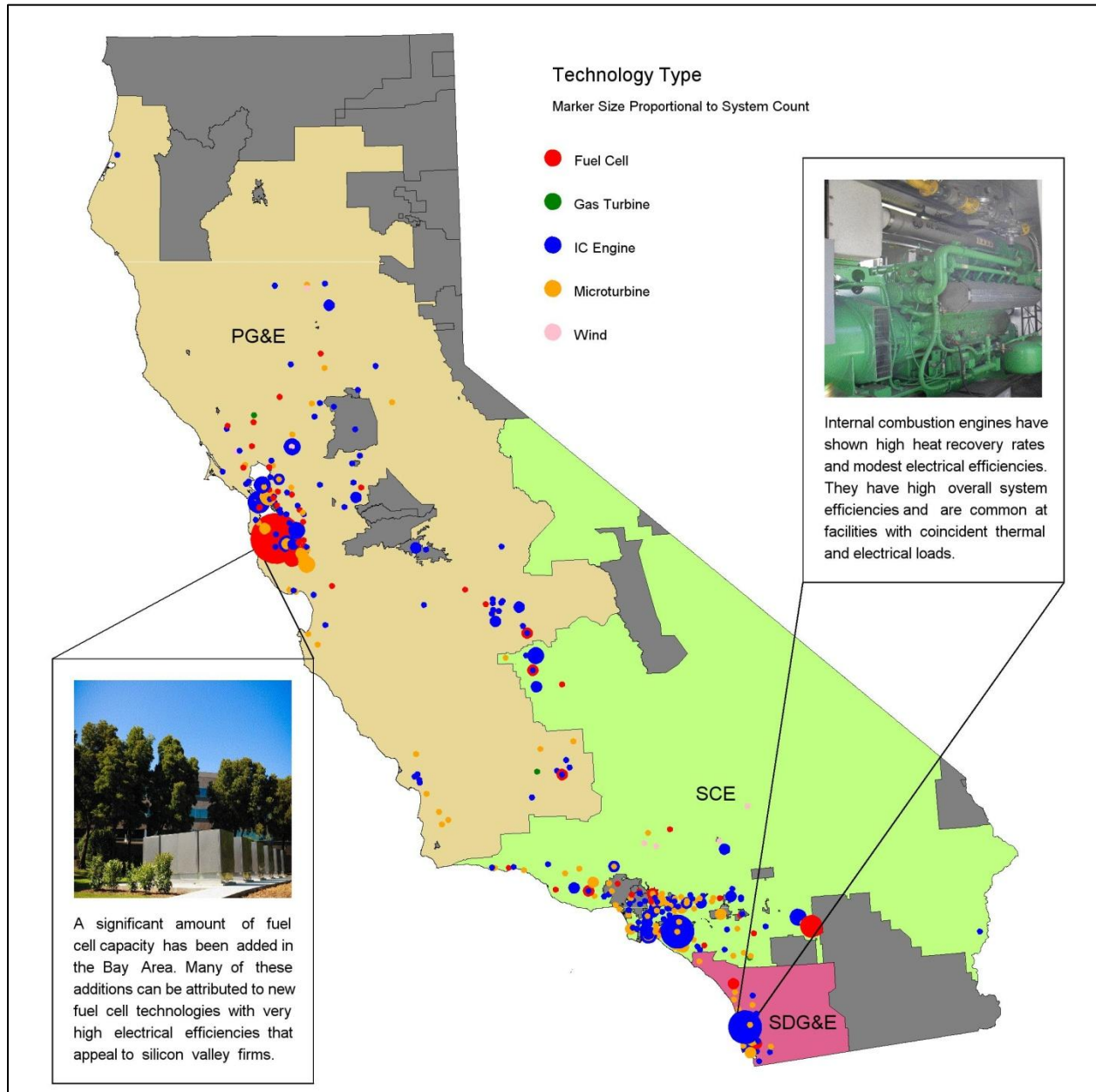
---

<sup>1</sup> Effective January 1, 2007, PV technologies installed on the customer side of the meter were eligible to receive incentives under the California Solar Initiative (CSI). Impacts from PV installed under the SGIP are reported in the CSI impact evaluation studies. Electronic versions of the CSI impact studies are located at: <http://www.cpuc.ca.gov/PUC/energy/Solar/evaluation.htm>

<sup>2</sup> As of 12/31/2011, there were 10 wind projects representing 6.8 MW of rebated capacity in the SGIP. However, metered electricity data were available for only one project.



Figure 3-1: Distribution of SGIP Projects by Electric Service Territory<sup>3</sup>



<sup>3</sup> For simplicity, this map shows the distribution of SGIP projects by IOU electric service territory. Although SCG is a Program Administrator, SCG is a natural gas provider and works with other electric utilities (e.g., SCE) to provide electrical connections. As such, SCG’s service territory is not shown on this map, but with the recognition that SCG’s SGIP projects are represented within the other IOU electric service territories. Similarly, CCSE is an SGIP program administrator and administers the SGIP on behalf of SDG&E but does not have a service territory.

### **3.3 Background**

#### **3.3.1 Definitions**

We categorized the status of SGIP projects into three groups according to their stage of development within the SGIP implementation process: Active projects, Inactive projects, and Complete projects. Program Administrators use significantly more classifications in defining project stages in the implementation process. However, for the purpose of grouping SGIP projects to assess impacts, we have stayed with a more general set of classifications.

Active projects have applied for a rebate and are in the queue working through the program requirements needed to receive an incentive payment. These represent SGIP projects that have not been withdrawn, rejected, completed, or placed on a waiting list. Over time, Active projects will migrate either to the Complete or to the Inactive category.

Inactive projects consist of SGIP projects that are no longer making forward progress in the SGIP implementation process. These projects have been withdrawn, rejected or cancelled by the applicant or the PA.

Complete projects represent SGIP projects for which the generation system has been installed, the system installation verified through an on-site inspection, and an incentive payment has been issued. The impacts evaluation is conducted on all projects in the Complete category.<sup>4</sup>

Complete projects are further classified into Decommissioned, Unknown, and On-line categories. Decommissioned projects are ones in which the generation equipment has been disconnected and removed from the project site. On-line projects include projects that are currently operational. However, on-line projects also include projects that may be down temporarily for various reasons such as maintenance. There are also projects for which we do not know the operational status because the project applicants are no longer traceable. These projects are lumped into the Unknown category.

#### **3.3.2 Implementation Status**

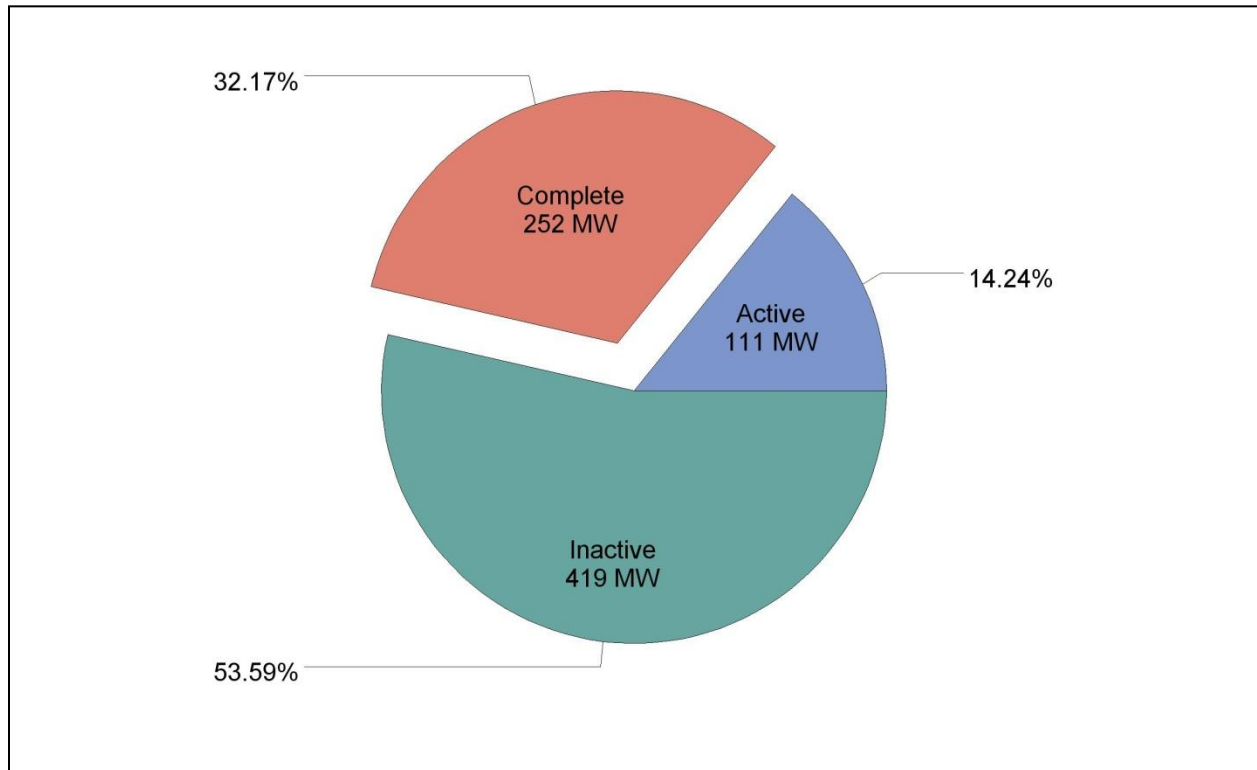
Since 2001, over 1,500 projects have applied for incentives to the SGIP. Forty-seven percent (718 projects) that applied to the SGIP were withdrawn, rejected, or cancelled, and as such fell into the Inactive category. Thirty-six percent (544 projects) successfully completed the application process and received rebates. By the end of 2011, the 264 projects constituting Active projects were in various stages of the incentive and implementation process and represented 17% of all projects that have applied to the SGIP. These Active projects will eventually become either Complete or Inactive projects.

---

<sup>4</sup> For this report, Complete projects are also sometimes referred to as completed projects.

Figure 3-2 shows a breakout of SGIP projects in the three status categories by rebated capacity. The timeframe covers projects applying to the SGIP from program inception in 2001 to the end of calendar year 2011. Figure 3-2 shows that nearly 50% of the project capacity coming into the SGIP made it into the Complete or Active status by 2011. In comparison, project success rates for renewable projects under qualifying facility status has been measured at 45%<sup>5</sup> and typical success rates for research and development applicants making it to implementation are less than 20%. Consequently, SGIP applicants have a reasonably high success rate, making the SGIP a relatively good investment for applicants.

**Figure 3-2: SGIP Projects Status by Rebated Capacity**



### 3.3.3 Program Trends

In order to put the status of the SGIP at 2011 in context, it is good to look at ways in which the program has changed over time. Changes in fuel use and technology type provide some interesting insights into the SGIP.

Figure 3-3 shows trends in SGIP fuel use from 2001 through the end of 2011. Fuel use is shown in terms of the amount of new rebated capacity by year in the SGIP. Historically, the SGIP has been dominated by projects using natural gas as the fuel resource (reported in the figure as non-

<sup>5</sup> California Energy Commission, “Building a ‘Margin of Safety’ Into Renewable Energy Procurements,” CEC300-2006-004, January 2006.

renewable fuel). However, the fraction which natural gas contributed each year gradually decreased over time with increasing use of renewable fuel resources. Beginning in 2010 and continuing through 2011, there was a marked increase in the fraction of SGIP capacity powered by renewable resources; primarily renewable biogas (specifically directed biogas) and wind.

**Figure 3-3: Rebated Capacity Trends by Fuel Type**

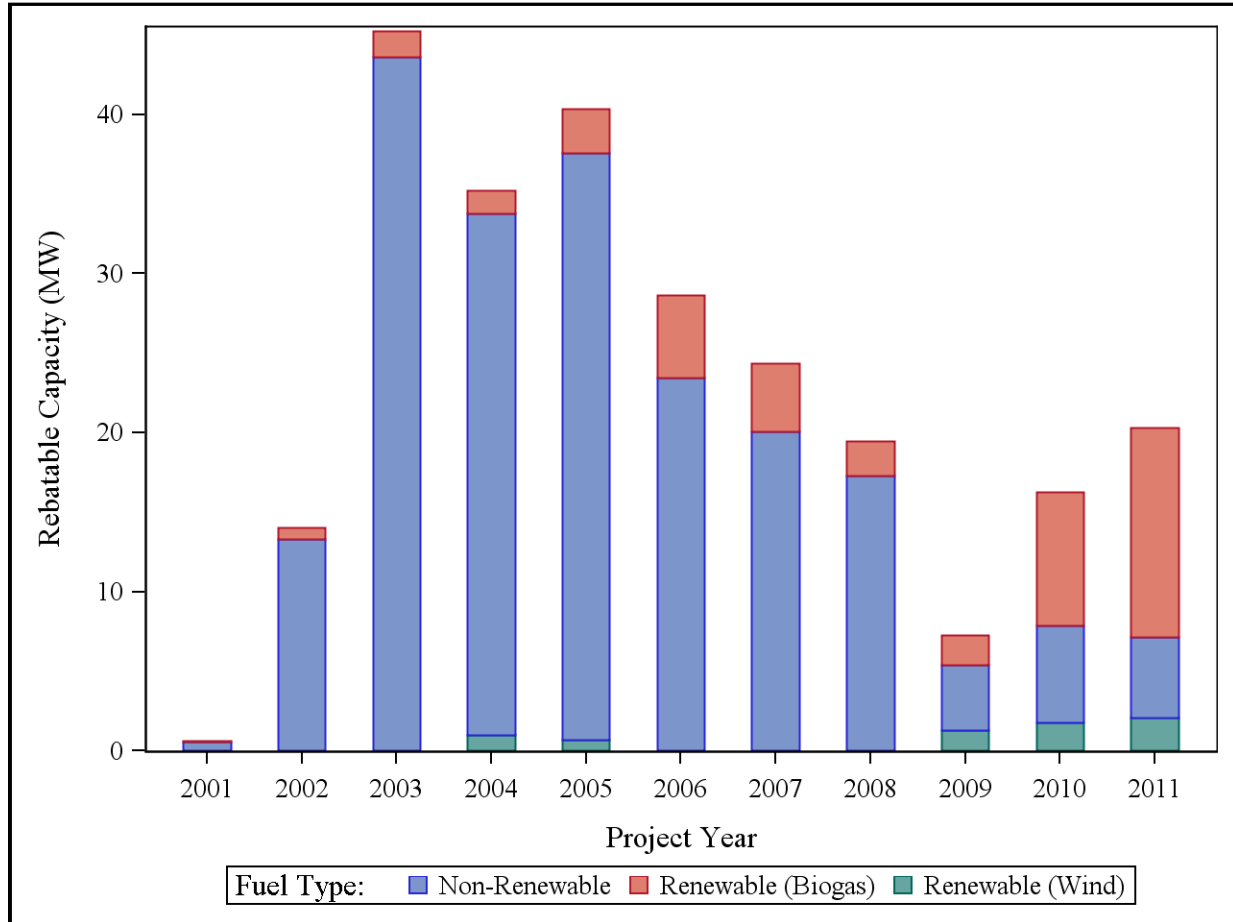
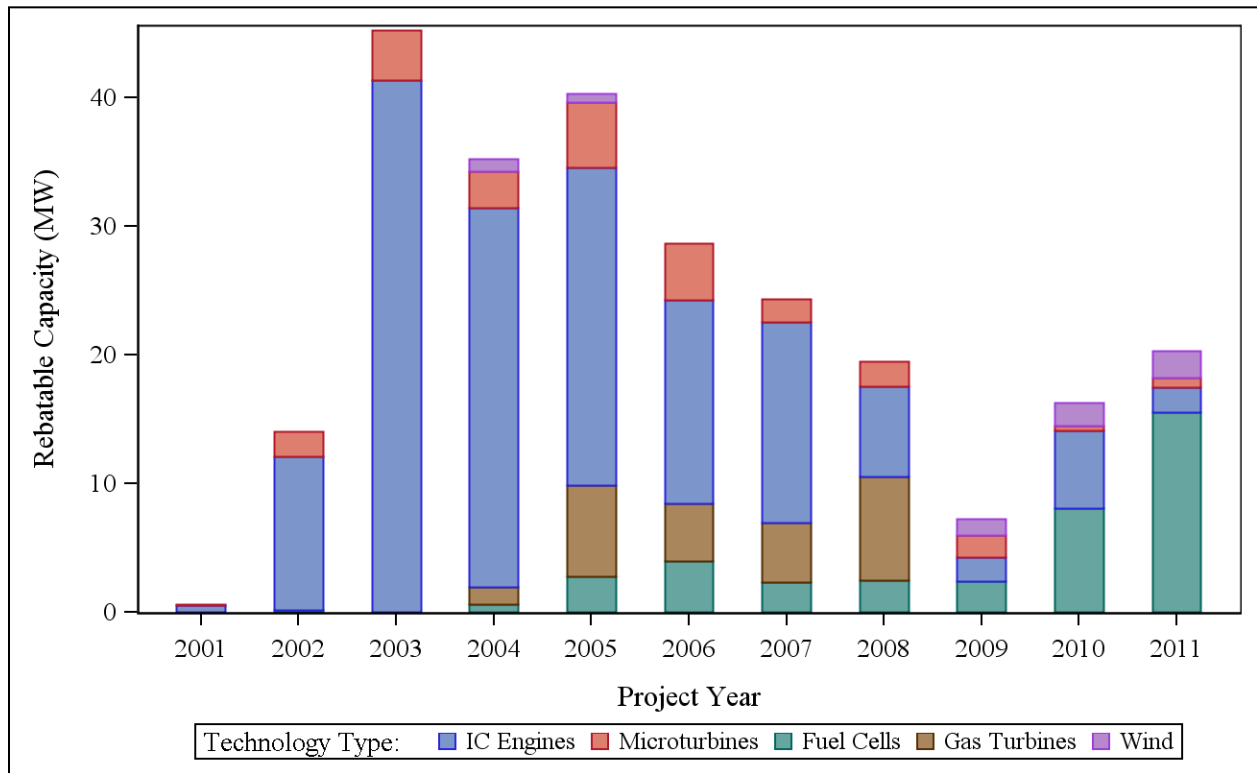


Figure 3-4 shows trends in SGIP technology type each year from 2001 through 2011. The trends in technology type are shown in terms of the amount of rebated capacities each year. IC engines dominated the SGIP in the early years of the program. By 2006, IC engines showed significant decline in the fraction of new rebated capacity and there was increased diversity in technology type. By 2009, there was marked increase in the fraction of new rebated capacity supplied by fuel cells and wind technologies. By 2011, the new rebated capacity was dominated by fuel cells.

In addition, both Figure 3-3 and Figure 3-4 show the gradual decline in rebated capacity within the SGIP beginning in 2005 and the resurgence in the program beginning in 2009. By the end of 2011, there were 808 projects in the Complete and Active pools with a rebated capacity of 363 MW. Though the number of projects grew between 2010 and 2011, the rebated capacity did not

increase significantly. The rebated capacity increase for both Complete and Active projects for the two years was about 20 MW.

**Figure 3-4: Rebated Capacity Trends by Technology**



Keeping in mind how the SGIP has changed over time we can now examine in greater detail the technology and fuel characteristics of the SGIP portfolio as of 2011.

### 3.4 Technology and Fuel Type Characteristics of Projects

#### 3.4.1 SGIP Complete Projects

By 2011, the SGIP was made up of 544 Complete projects. Seventy-three of those projects were completed in 2011 increasing the rebated capacity of Complete projects by 20 MW to a total of 252 MW.

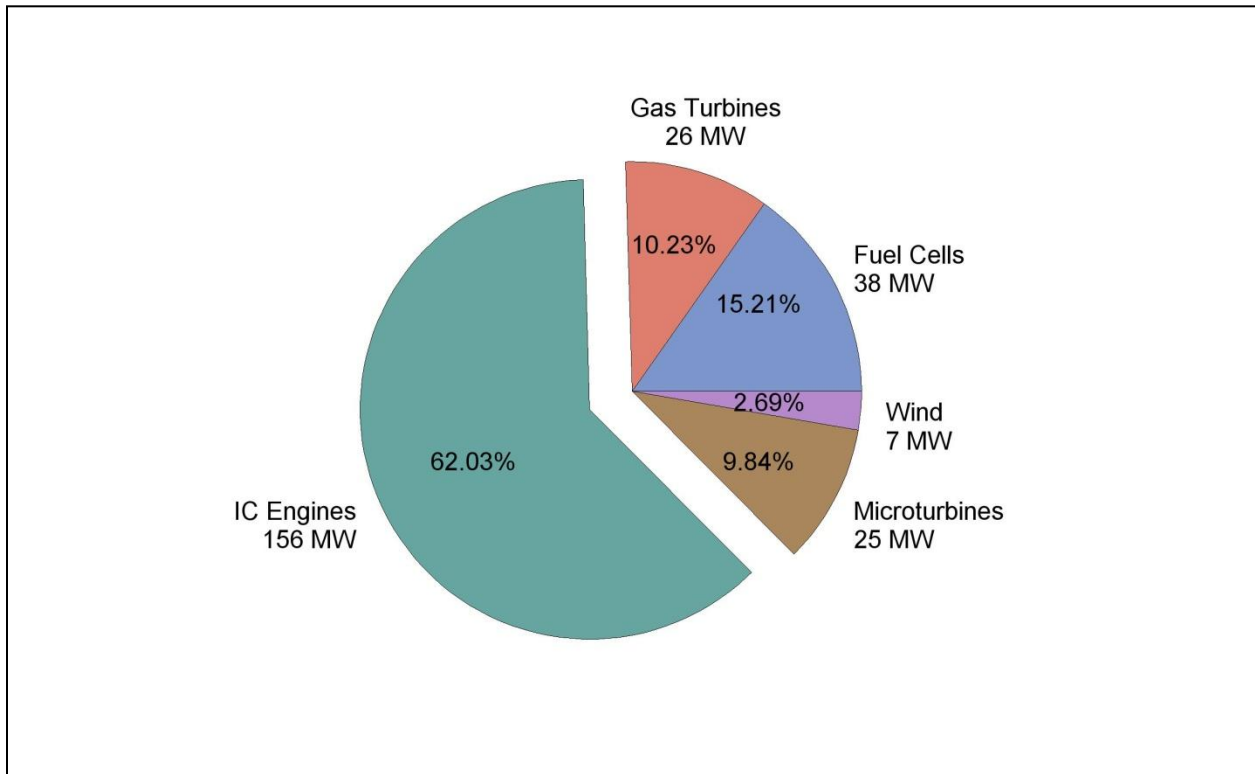
#### Technology Characteristics

Table 3-1 shows the distribution of Complete projects by technology type. The table provides information on the distribution in terms of number of projects and rebated capacity. The technology distribution is depicted graphically in Figure 3-5. While 2010 and 2011 both showed significant new capacity in fuel cells, IC engines continue to be the dominant technology in terms of both capacity and number of projects.

**Table 3-1: Quantity and Capacity of Complete Projects by Technology**

Technology	Complete		Percent of Total Rebated Capacity
	No. of Projects	Rebated Capacity (MW)	
IC Engines	255	156	62%
Fuel Cells	131	38	15%
Gas Turbines	8	26	10%
Microturbines	140	25	10%
Wind	10	7	3%
<b>Total</b>	<b>544</b>	<b>252</b>	<b>100%</b>

**Figure 3-5: Quantity and Capacity by Technology**



Complete projects can be further characterized by their operational status. In particular, Complete projects can be classified as being on-line, decommissioned or unknown. On-line projects are connected to the grid and provide power. Some of the on-line projects may be temporarily off for various reasons such as maintenance. However, for the impact analysis, they are still considered on-line and operational. Decommissioned projects represent SGIP customer

sites where the DG equipment has been retired and the equipment removed from the project site.<sup>6</sup> Decommissioned projects consume no fuel and contribute no power. However, decommissioned projects still contributed rebated capacity to the SGIP and must be taken into account. There are some systems that we do not know the operational status because contact with the facility or project applicant is no longer available. These projects are lumped into an Unknown category.

Table 3-2 provides information on Complete projects broken out by technology and operational status through the end of 2011.

**Table 3-2: Operation Status of Complete Projects by Technology Type**

Technology	On-line			Decommissioned			Unknown		
	No. of Projects	Rebated Capacity (MW)	Percent Total Rebated Capacity	No. of Projects	Rebated Capacity (MW)	Percent Total Rebated Capacity	No. of Projects	Rebated Capacity (MW)	Percent Total Rebated Capacity
IC Engines	176	115.4	62%	33	14.9	76%	46	25.9	57%
Fuel Cells	109	28.6	15%	6	1.3	6%	16	8.4	19%
Gas Turbines	7	24.5	13%	0	0	0	1	1.2	3%
Microturbines	92	18.3	10%	21	3.4	17%	27	3.1	7%
Wind	0	0	0	0	0	0	10	6.8	15%
<b>Total</b>	<b>384</b>	<b>186.8</b>	<b>100%</b>	<b>60</b>	<b>19.6</b>	<b>100%</b>	<b>100</b>	<b>45.3</b>	<b>100%</b>

Examining Table 3-2 leads to several observations. First, it’s impressive to note that after eleven years of operation, the SGIP has had only 19.6 MW of decommissioned projects out of a program total of 252 MW (less than 8% of the total rebated capacity). Second, the older IC engine and microturbine projects were most likely to have been retired and decommissioned. Although not shown in Table 3-2, fifty-four of the sixty decommissioned projects were installed before 2006. Fuels cells represented newer systems and were less likely to have been decommissioned. Last, there was a significant capacity (nearly 18% of the total rebated capacity) of SGIP projects by 2011 for which the operational status was unknown.

**Fuel Characteristics**

Figure 3-6 shows fuel use of SGIP projects at the end of 2011. Eighty percent of the SGIP rebated capacity was produced using non-renewable fuels (i.e., natural gas) and the remainder with renewable fuels (i.e., biogas and wind). In 2011, 34 renewable biogas fueled projects comprising 13 MW of rebated capacity became Complete projects. This compares with 64

---

<sup>6</sup> SGIP projects are not required to report a decommissioned status. Generally, we discover systems have been decommissioned when we call the customer or applicant to check why the project is not showing fuel consumption or energy generation and find the system has been removed. In other instances, the project may call us to remove monitoring equipment installed on behalf of the PA.

biogas projects representing 29 MW of rebated capacity that reached Complete status since the beginning of the SGIP. This represents almost 50% increase in biogas use in the program.

**Figure 3-6: Quantity and Capacity by Fuel Type**

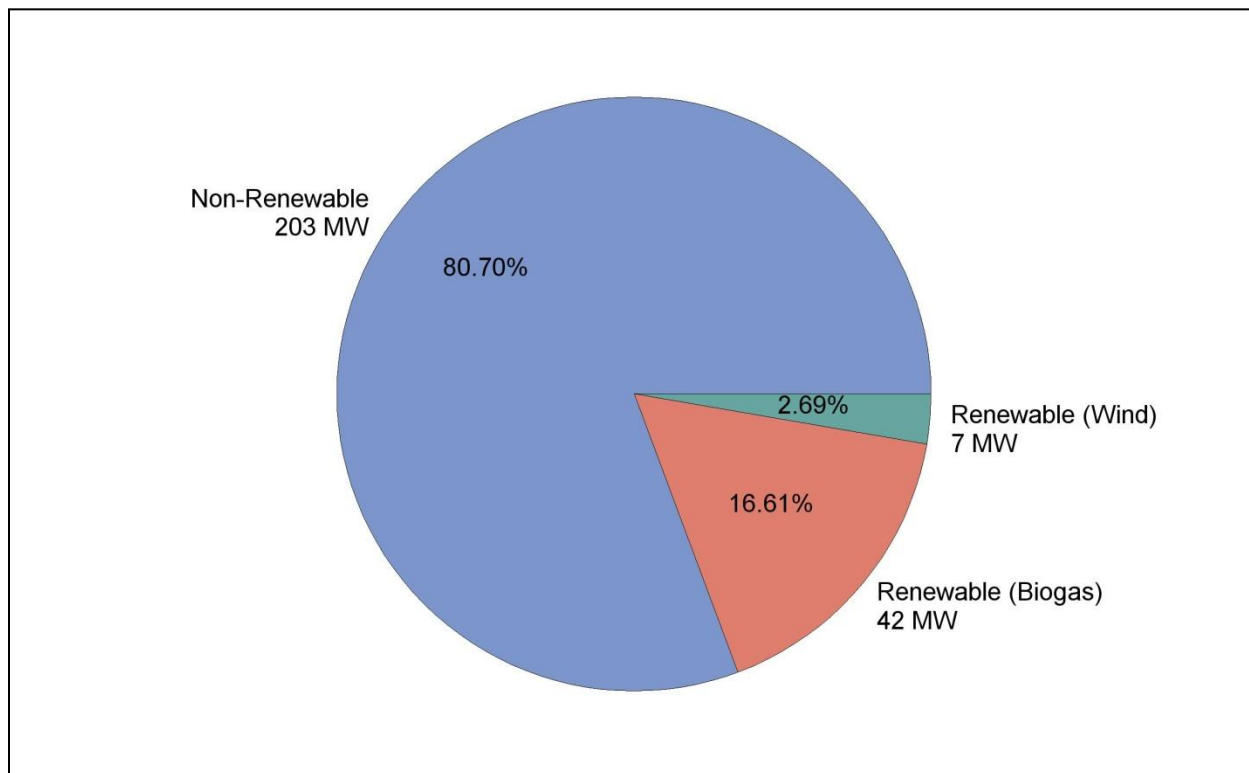


Table 3-3 shows the operational status of Complete projects based on fuel type. The renewable (biogas) includes both on-site biogas and directed biogas. The information shows that fuel type does not appear to have influenced the number of projects that were decommissioned. Projects were decommissioned in about the same proportion irrespective of fuel type.

**Table 3-3: Operation Status of Complete Projects by Fuel Type**

Technology	On-line			Decommissioned			Unknown		
	No. of Projects	Rebated Capacity (MW)	Percent of Total Rebated Capacity	No. of Projects	Rebated Capacity (MW)	Percent of Total Rebated Capacity	No. of Projects	Rebated Capacity (MW)	Percent of Total Rebated Capacity
Non-Renewable	306	154.3	83%	53	16.3	83%	77	32.5	72%
Renewable (Biogas)	78	32.4	17%	7	3.4	17%	13	6.0	13%
Renewable (Wind)	0	0	0	0	0	0	10	6.8	15%
<b>Total</b>	<b>384</b>	<b>186.8</b>	<b>100%</b>	<b>60</b>	<b>19.6</b>	<b>100%</b>	<b>100</b>	<b>45.3</b>	<b>100%</b>



### 3.4.2 SGIP Active Projects

#### Technology Characteristics

Table 3-4 provides information on the potential rebated capacity of Active projects in the SGIP at the end of 2011. Active projects represent projects that were in the queue; potentially making their way towards a Complete status. At the end of 2011, the majority of projects in the queue focus consisted of advanced energy storage and fuel cells. In addition, of the 264 projects in the queue, 72 were 10 kW or smaller and 37 were greater than 1 MW in their potential rebated capacity. The projects less than 10 kW were predominantly advanced energy storage projects. The projects greater than 1 MW in capacity were mostly fuel cells and wind turbines with the largest ones being wind projects. Although not all Active projects will move to a Complete project status, the information in Table 3-4 suggest likelihood that fuel cells and wind projects may have a significant influence on the 2012 or 2013 makeup of the SGIP.

**Table 3-4: Project Characteristics of Active Projects**

Technology	Active		Percent of Total Potential Rebated Capacity
	No. of Projects	Potential Rebated Capacity (MW)	
Fuel Cells	110	59	53%
Wind	20	34	30%
Advanced Energy Storage	125	12	10%
IC Engines	5	4	4%
Microturbines	4	3	2%
<b>Total</b>	264	111	100%

## 3.5 Financial and Cost Characteristics

### 3.5.1 Incentives Paid

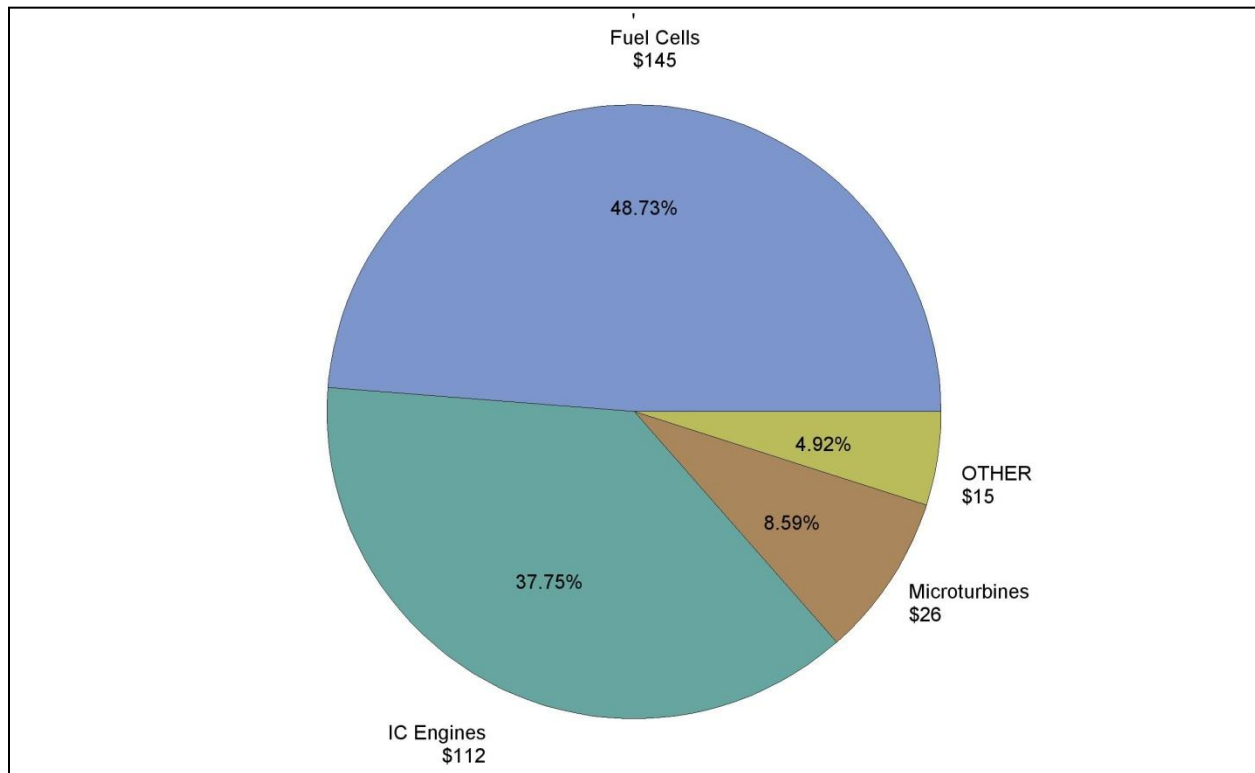
Table 3-5 summarizes the cumulative SGIP incentives paid as of December 31, 2011 by technology type for Complete projects. A total of \$298 million in SGIP incentives had been paid to Complete projects since the program's inception with \$64 million paid in 2011 alone.

**Table 3-5: Rebated Capacity and Incentives Paid**

Technology	Incentives Paid and Capacities		
	Rebated Capacity (MW)	Wt.Avg. \$/W	Total (\$ MM)
Fuel Cells	38	\$3.79	\$145
IC Engines	156	\$0.72	\$112
Microturbines	25	\$1.03	\$26
Wind	7	\$1.18	\$8
Gas Turbines	26	\$0.26	\$7
Overall	252	\$1.18	\$298

Figure 3-7 graphically depicts the quantity and proportion of incentives paid to Complete projects by technology type. Over 80% of the incentives were paid to two technology types (IC engines and fuel cells). However, it is interesting to note that while fuel cells received over 5 times the incentive payment (\$/rebated kW) as IC engines, IC engines provided over 4 times as much rebated capacity as fuel cells.

**Figure 3-7: Quantity of Incentives Paid (\$ Millions) by Technology Type**



### 3.5.2 Incentives Reserved

Table 3-6 summarizes the incentives reserved for Active projects. Reserved incentives represent the backlog of SGIP projects. PAs could use incentive payment status to examine the funding backlog of SGIP projects by technology and fuel type; and determine how backlog may influence both funding diversity and future program makeup. This could be particularly helpful in meeting the desired objectives of diversifying distributed energy resources and reducing over exposure to any one product or manufacturer. At the end of 2011, the SGIP reserved backlog totaled \$277 million. Fuel cells, wind, and advanced energy storage represented 95% of the reserved funds and 97% of the projects in the queue.

**Table 3-6: Incentives Reserved for Active Projects**

Technology	Reserved Incentives and Capacities		
	Potential Rebated Capacity (MW)	Wt.Avg. \$/W	Total (\$ MM)
Fuel Cells	59	\$3.23	\$191
Wind	34	\$1.38	\$46
Advanced Energy Storage	12	\$2.40	\$28
IC Engines	4	\$2.19	\$10
Microturbines	3	\$0.88	\$2
Overall	111	\$2.49	\$277

Figure 3-8 graphically depicts the quantity and proportion of reserved incentives by technology type. If all the reserved fuel cell projects that have reserved incentives moved to Complete project status, fuel cells would represent a vast majority of the future SGIP funding. In contrast, both IC engines and microturbines would constitute less than 5% of the future funding.

Figure 3-8: Quantity of Incentives Reserved (\$ Millions) by Technology Type

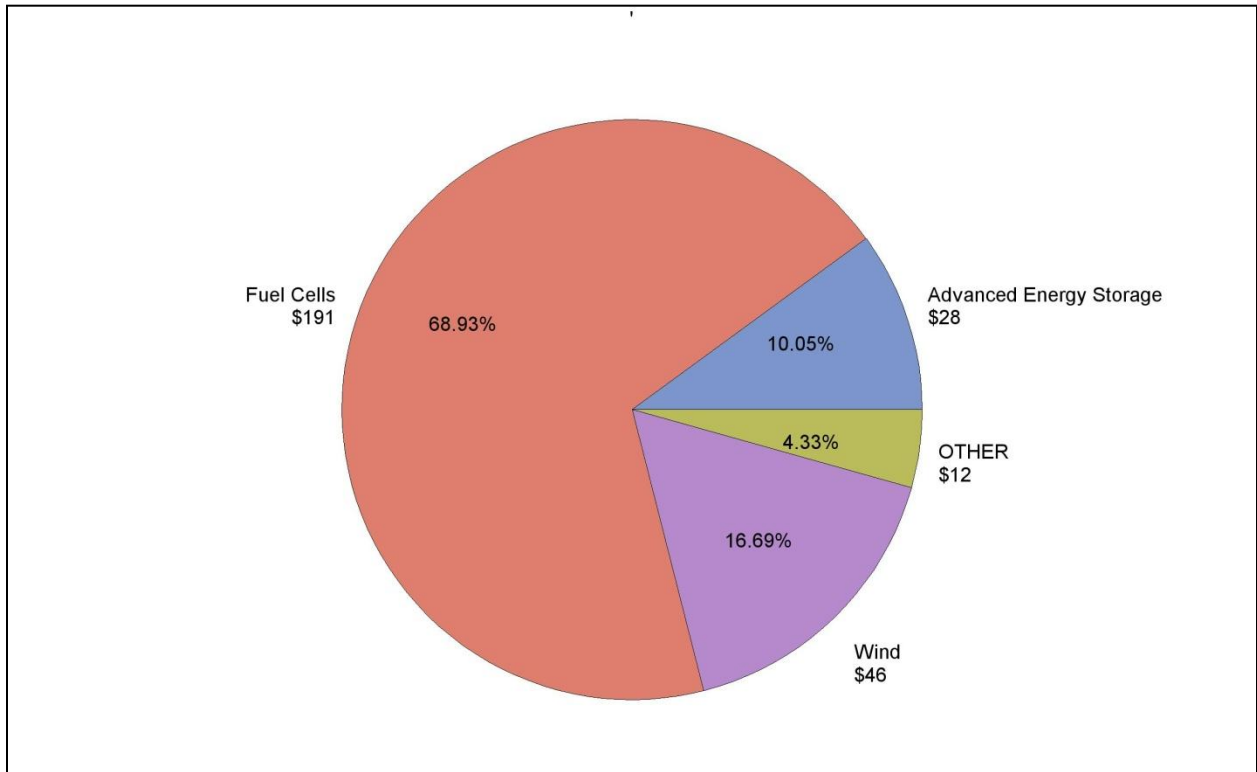
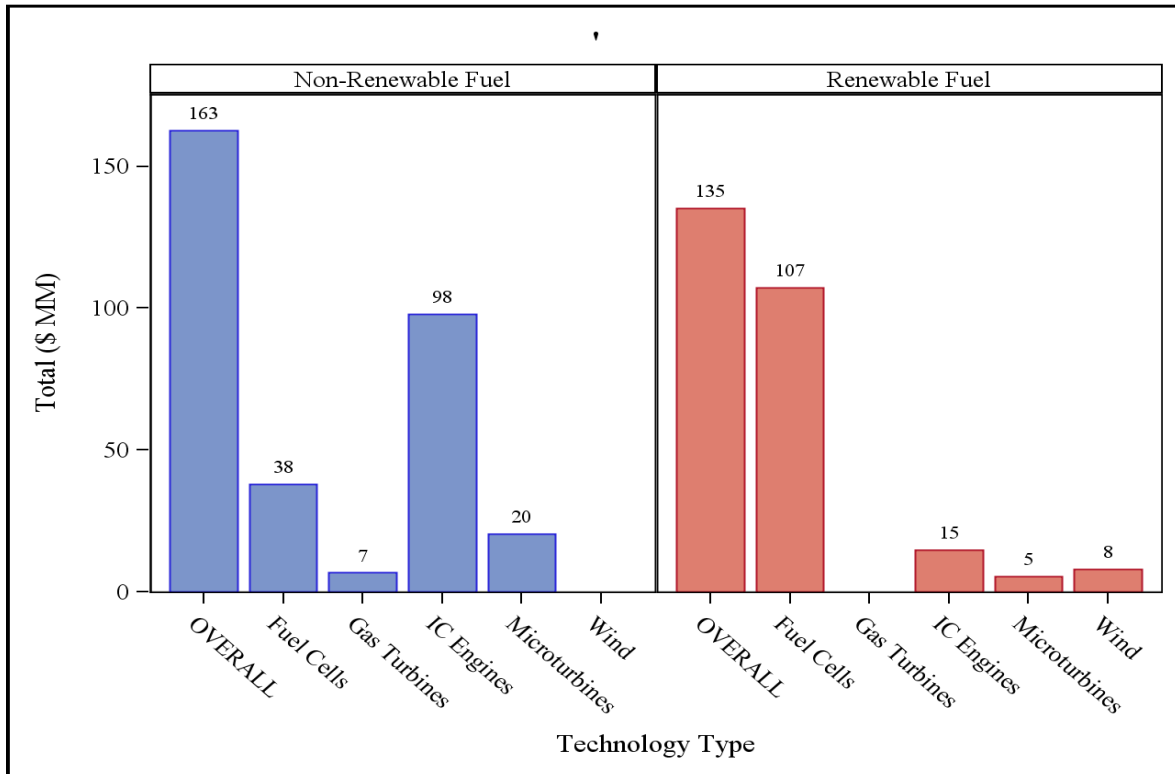


Figure 3-9 illustrates the incentives paid on the different fuel types since the inception of the program. The fuel types are classified as non-renewable (i.e., natural gas) and renewable, which consists of biogas (both directed biogas and on-site biogas) and wind. In 2011, incentives totaling \$64 million were paid for Complete projects. Of this amount, \$57 million was paid for renewable projects and \$7 million for non-renewable projects.

**Figure 3-9: Incentives Paid by Fuel Type**



### 3.6 Participants’ Out-of-pocket Costs after SGIP Incentive

#### 3.6.1 Participants’ Out-of-pocket Costs for Complete Projects

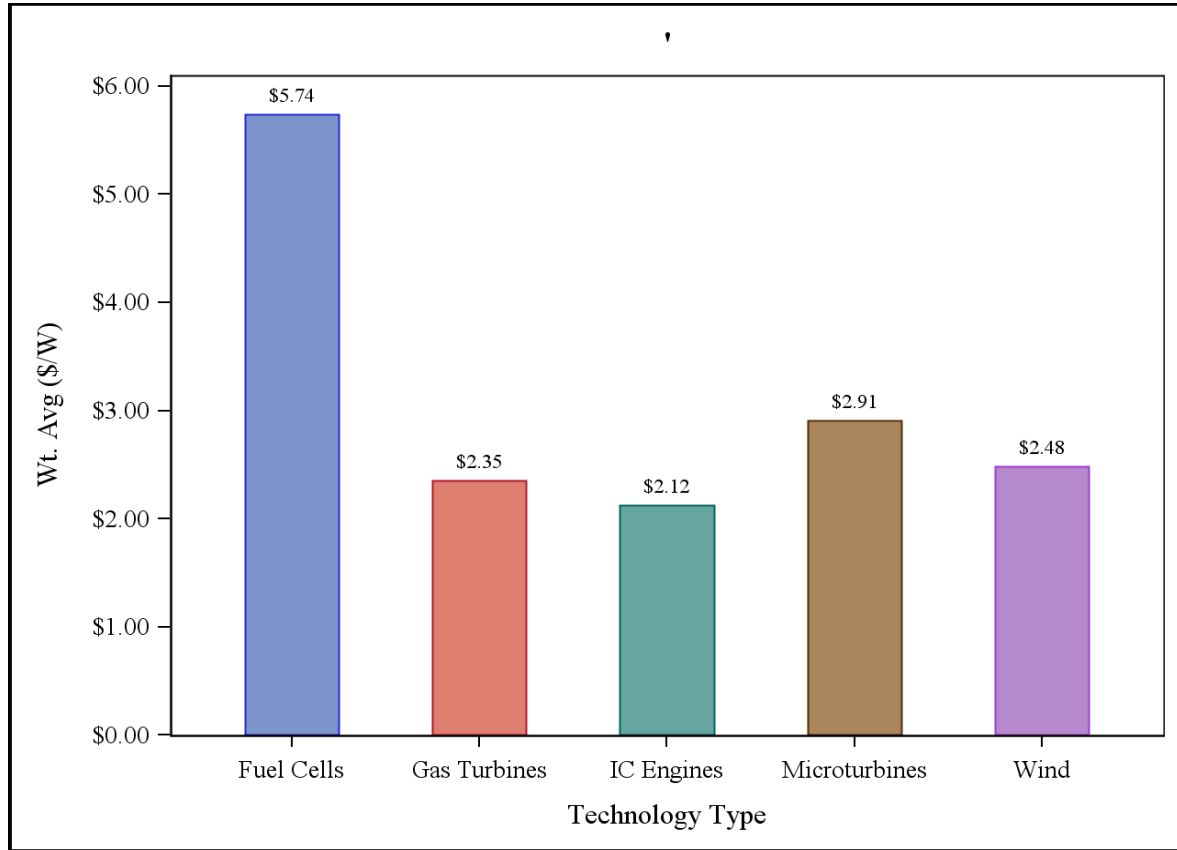
Participants’ out-of-pocket costs are calculated as the total eligible project cost less the SGIP incentive. These costs for complete projects are summarized in Table 3-7 and graphically illustrated in Figure 3-10 on a weighted basis. There was no significant increase in the out-of-pocket costs between 2010 and 2011. The total out-of-pocket costs for the program since 2001 are \$700 million with \$110 million accounting for 2011 costs alone.

**Table 3-7: Participants’ Out-of-pocket Costs for Complete Projects**

Technology	Paid		
	Total (MW)	Wt. Avg (\$/W)	Total (\$MM)
Fuel Cells	38	\$5.74	\$220
Microturbines	25	\$2.91	\$72
Wind	7	\$2.48	\$17
Gas Turbines	26	\$2.35	\$61
IC Engines	156	\$2.12	\$331
Overall	252	\$2.78	\$700

For Complete projects, fuel cells had the highest costs on a cost-per-watt basis, followed by microturbines. Fuel cells represented approximately double the cost of all other technology types on a dollar per watt basis.

**Figure 3-10: Weighted Participants’ Out-of-pocket Cost on Complete Projects**



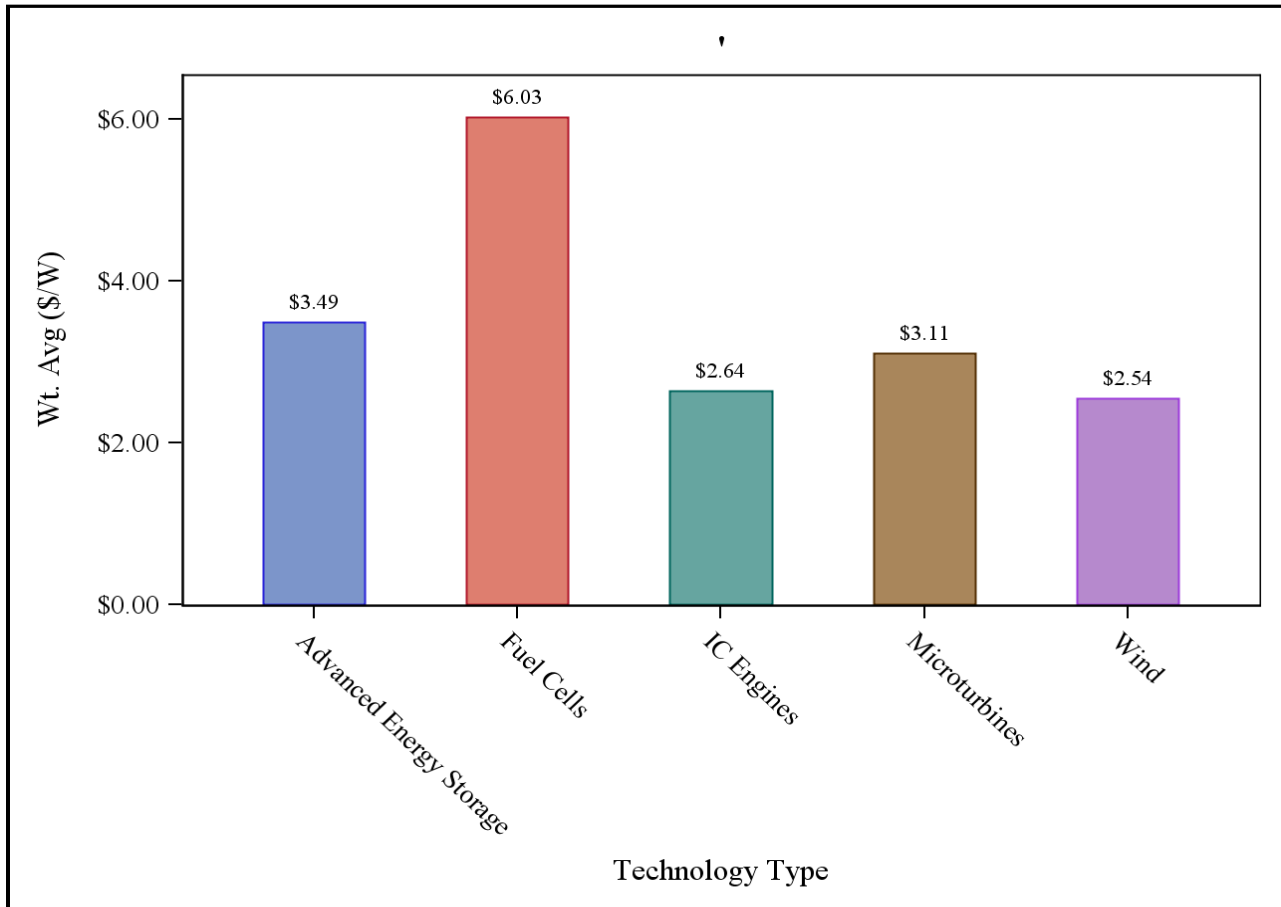
**3.6.2 Participants’ Out-of-pocket Costs for Active Projects**

Table 3-8 shows the out-of-pocket costs for projects in the queue. Fuel cells continued to have double the out-of-pocket costs of other technologies.

**Table 3-8: Participants’ Out-of-pocket Costs for Active Projects**

Technology	Reserved		
	Total (MW)	Wt. Avg (\$/W)	Total (\$MM)
Fuel Cells	59	\$6.03	\$356
Microturbines	3	\$3.11	\$8
Wind	34	\$2.54	\$86
IC Engines	4	\$2.64	\$12
Advanced Energy Storage	12	\$3.49	\$40
Overall	111	\$4.51	\$502

**Figure 3-11: Weighted Participants’ Out-of-pocket Cost on Active Projects**

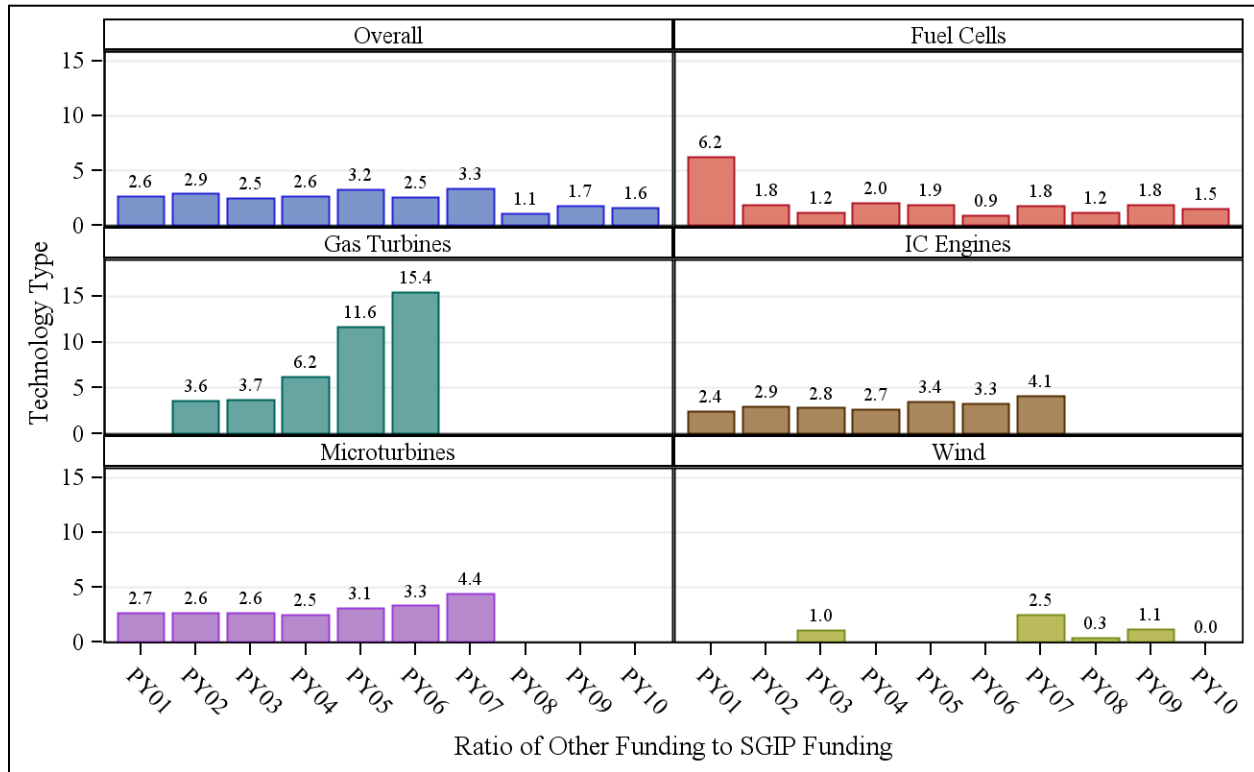


**3.6.3 Leveraging of SGIP Funding**

Leveraging of SGIP incentive funding is important because it represents the ability of the program to attract support for deployed projects and increase the effectiveness of the program’s objectives. Figure 3-12 shows the leveraging ratio by program year for the different technologies. It shows the ratio of the total project costs less incentive to incentive paid based on the program year. The program years span through PY10 and do not include PY11 because projects Completed in PY11 were actually paid in 2012.<sup>7</sup> Since 2001, over \$298 million in incentive payments have been made for projects costing more than \$994 million, which is a remarkable program leveraging ratio of 2.35. This means that for every SGIP dollar, the program participants have contributed \$2.35. Gas turbines have leveraged the most dollars because of their relatively large size.

<sup>7</sup> The program year is a designation made by the PAs and usually references the year an application was made to the program. It is not the calendar year the incentive was paid.

**Figure 3-12: Ratio of Other Funding to SGIP Incentive Funding by Program Year**



### 3.7 Program Administrator Characteristics

This section provides summary information on the status of the SGIP at the PA level at the end of 2011.

#### 3.7.1 Complete SGIP Projects by PA

Table 3-9 shows information on the distribution of SGIP projects among the four PAs at the end of calendar year 2011. PG&E had the highest population of projects and greatest rebated capacity, capturing approximately 40% of the rebated capacity within the SGIP. SCG and SCE together represented nearly 50% of the total rebated capacity of the SGIP and CCSE represented approximately 10% of the program’s rebated capacity. As the capacities are not normalized by number of utility customers or area of service territory, it is difficult to make meaningful comparisons between the different rebated capacities for the PAs.

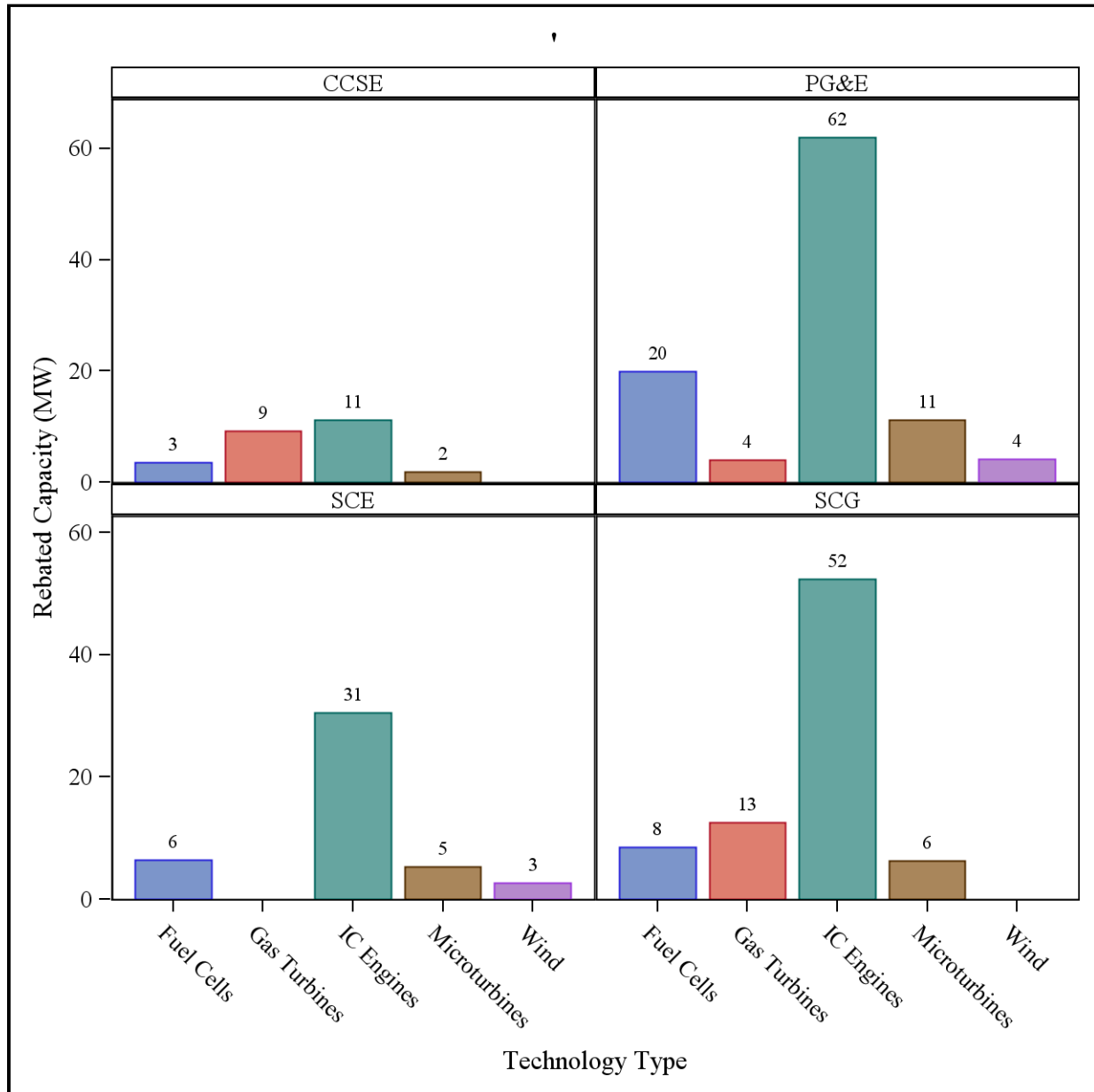


**Table 3-9: Quantity and Capacity of Complete Projects by PAs**

<b>Program Administrator</b>	<b>No. of Projects</b>	<b>Rebated Capacity (MW)</b>	<b>Percent of Total Rebated Capacity</b>
<b>PG&amp;E</b>	257	101	40%
<b>SCG</b>	134	80	32%
<b>SCE</b>	105	45	18%
<b>CCSE</b>	48	26	10%
<b>Total</b>	544	252	100%

Figure 3-13 shows the distribution of SGIP projects by PA and technology type based on rebated capacity. Several observations can be made relative to data presented in Figure 3-13. First, internal combustion engines (IC engines) tend to dominate the SGIP regardless of PA. Second, while gas turbines represent a significant portion of CCSE and SCG’s portfolio or projects, SCE has no gas turbines in its project pool. Third, the figure also shows wind projects in both PG&E and SCE territories. These wind projects represent a resurgence in wind energy projects in the SGIP.

**Figure 3-13: Distribution of Technology Type by PA (Complete Projects)**



**3.7.2 Active SGIP Projects by PA**

Table 3-10 shows the breakdown of Active projects by PA. SCE has the highest rebated capacity in the queue with 24 fuel cells and 10 wind projects.

**Table 3-10: Quantity and Capacity of Active Projects by PAs**

Program Administrator	No. of Projects	Rebated Capacity (MW)	Percent of Total Rebated Capacity
PG&E	109	34	30%
SCE	83	44	39%
CCSE	49	16	14%
SCG	23	18	16%
<b>Total</b>	<b>264</b>	<b>111</b>	<b>100%</b>

**3.7.3 Overlap of SGIP Projects between IOU and Municipal Utilities**

Customers of the California IOUs fund the SGIP through a cost recovery process administered by the CPUC. Every IOU customer is eligible to participate in the SGIP. In some cases, these same IOU customers were also customers of municipal utilities. As a result, deployed SGIP projects can have impacts on both IOU and municipal utilities.

Table 3-11 shows that 7% of the rebated capacity was provided by municipals with the largest portion generated by fuel cells. There were 24 municipal projects (9 MW rebated capacity) in 2011 compared to 17 projects (2 MW rebated capacity) in 2010. This represented a fourfold increase in rebated capacity in 2011 compared to the prior year. The largest portion of Complete projects in 2011 was in PG&E territory with 12 projects and 5 MW rebated capacity.

**Table 3-11: Overlap of IOU and Municipal for On-line Projects**

PA Territory by Municipal/IOU Overlap		Rebated Capacity					Total	
		(MW)						
		IC Engines	Micro turbines	Fuel Cells	Wind	Gas Turbines	Total Rebated Capacity (MW)	Percent of Total Rebated Capacity
PG&E	IOU	62	10	17	2	4	96	38%
	Municipal	0	1	2	2	N/A	6	2%
SCG	IOU	50	5	2	N/A	13	69	27%
	Municipal	3	2	6	N/A	N/A	11	4%
SCE	IOU	30	5	6	3	N/A	44	17%
	Municipal	1	N/A	0	N/A	N/A	1	0%
CCSE	IOU	11	2	3	N/A	9	25	10%
	Municipal	N/A	N/A	0	N/A	N/A	0	0%
<b>Total</b>		<b>156</b>	<b>25</b>	<b>38</b>	<b>7</b>	<b>26</b>	<b>252</b>	<b>100%</b>

### **3.8 Key Observations**

The following key observations are made on the SGIP program status as of 2011:

- By the end of 2011, the SGIP had seen significant change in the makeup of the program. Through much of the SGIP's history, projects were powered by non-renewable resources. However, nearly 65% of the rebated capacity added in 2011 was powered by renewable resources; primarily directed biogas and wind energy. Similarly, the DG technologies comprising the SGIP have changed. Historically, IC engines have been the dominant prime mover in the SGIP. This began changing in 2009 and by 2011 fuel cells and wind systems were contributing the lion's share of new rebated capacity. Examination of the composition of the Active projects suggests this trend may be likely to continue in the future.
- There are 544 projects that have already received incentive payments and 264 in queue projects contributing 252 MW and 111 MW respectively.
- Approximately \$1 billion has been invested in the SGIP, with \$298 provided as SGIP incentives. This means that for every SGIP dollar, \$2.35 of other funds has been invested. This is a remarkable leveraging ratio.
- After eleven years of operation, less than 8% of SGIP projects (on a rebated capacity basis) were decommissioned. This is an impressive record that may be due to warranty requirements of the program and the value of the projects to utility customers who installed the SGIP projects.

# 4

## Electric Energy and Demand Impacts

---

### 4.1 Introduction

Electric impacts are key indicators of SGIP program success. Electric impacts can constitute a majority of the program's direct economic benefits. In particular, electric energy impacts can reduce program participants'<sup>1</sup> annual electric bills and energy purchases. Electric demand impacts during peak periods can also reduce program participants' time-of-use charges and peak power purchases. Reducing peak at the utility customer site through SGIP projects may also help utilities avoid the need to operate expensive peaking units. A primary goal of the SGIP at its inception was addressing peak demand and this remains a vital feature of the SGIP. In addition, the SGIP's ability to achieve GHG emission reductions is linked to the program's electric energy and demand impacts.

We start this section by discussing how capacity and use of that capacity can influence electric energy and demand impacts. Due to the importance of utilization, we discuss technology utilization trends and provide information on the factors (such as project age) that affect utilization. We also specifically discuss the manner in which utilization affects energy and demand for different SGIP technologies. With that information in hand, we then present and discuss electric demand impacts during peak periods of 2011, followed by a discussion of electric energy impacts from the SGIP in both PY11 and over the program lifetime. The section concludes with a summary of the electric energy and demand impacts at the PA level.

### 4.2 The Importance of Capacity and Utilization

Program impacts are primarily a function of two factors: the installed program capacity and the use of that capacity (referred to as utilization). Program capacity depends on successful program participation. That is, successful participation adds generating capacity to the program. As program capacity increases, so generally do program impacts. Capacity only contributes to impacts when the capacity is utilized. As program capacity utilization increases, so do program impacts.

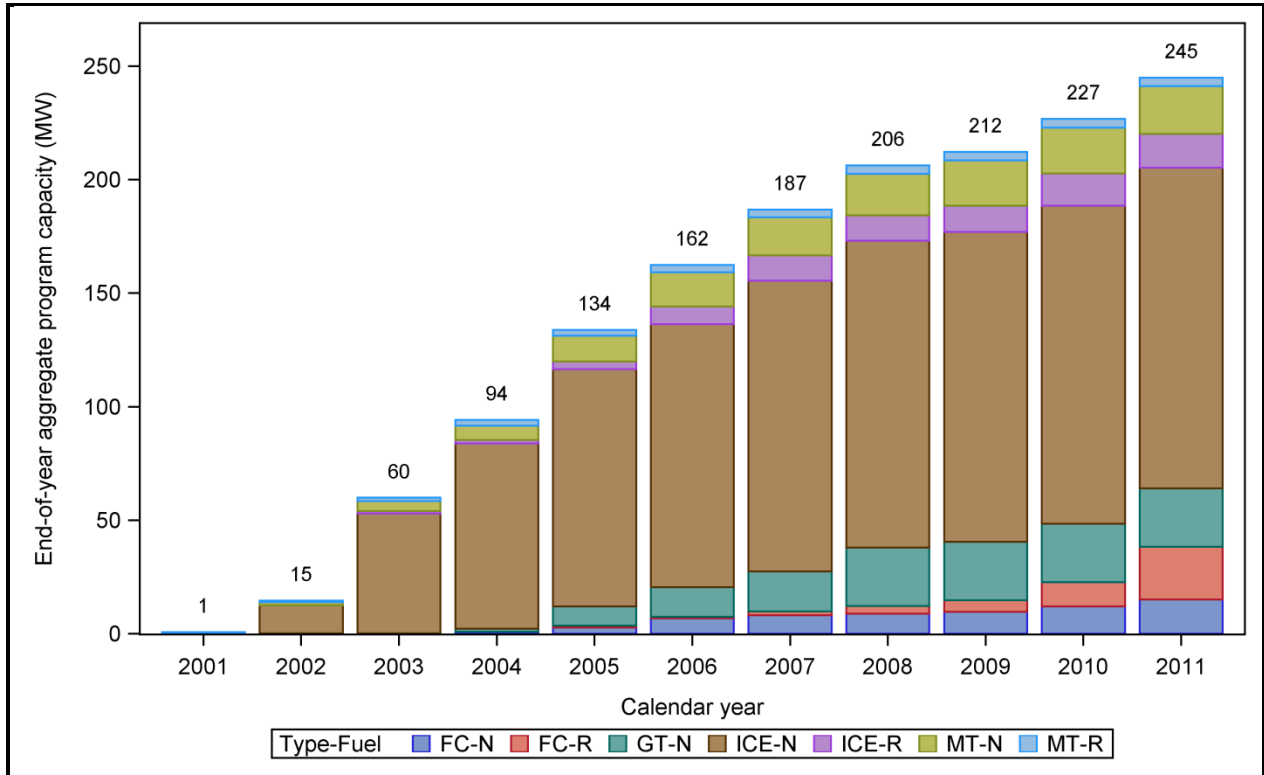
---

<sup>1</sup> SGIP project participants are utility customers. As such, project participants and utility customers are used interchangeably in this report depending on the specific issue being discussed.

### 4.2.1 Changes in Program Capacity over Time

Project participants and Program Administrators (PAs) cooperate to add capacity. Subsequent use of installed capacity depends on a wide assortment of factors. Among these are energy market prices and business decisions by project participants that are beyond the control of PAs.

**Figure 4-1: Cumulative Program Capacity Growth (without Wind)<sup>2</sup>**



As the program has progressed, program capacity and capacity utilization have changed. Figure 4-1 shows aggregate program capacity growth from 2001 to 2011. Program capacity reached 245 MW at the end of 2011. Figure 4-1 also shows the changing composition of program capacity in terms of technology and fuel types.

While program capacity has grown, its utilization has changed. The changes are partly a result of the changing technology composition of the program capacity. As Figure 4-1 shows, program capacity has been dominated by non-renewable IC engines (ICE-N). It also shows that the majority of ICE-N capacity in 2011 entered the program before 2007 and therefore was over 4

<sup>2</sup> Figure 4-1 does not include wind capacity. This section does not include wind technology due to lack of metered data from the 10 projects completed by the end of 2011. Figure 4-1 does not include wind capacity. This section does not include wind technology due to lack of metered data from the 10 projects completed by the end of 2011.

years old in 2011. As with most technologies, the performance of distributed generation systems declines over time. Declining utilization of older ICE-N projects put downward pressure on program-level capacity utilization and thus downward pressure on program impacts.

Use of installed program capacity also depends on energy demands at the SGIP facility and decisions made by the project participant on how to respond to those demands. Based on the loads they expect the project to meet, project participants decide when and how much to utilize project capacity.<sup>3</sup> Project participants face various and sometimes complex decisions regarding project capacity utilization. They must weigh the economics of purchasing natural gas to operate non-renewable projects to meet electric loads against directly purchasing that energy from their electric utility. In addition, project utilizations can change as natural gas and electricity costs change. Project participants must also decide what resources to devote to project maintenance. For instance, they must decide whether or not to replace components that have reached the end of their useful lives. Project maintenance decisions can have profound effects on electric conversion efficiency of a project, and reduced efficiency could lead to reduced project capacity utilization. These decisions can be extraordinarily complex as they are particular to the participant's financial situation and may depend on issues far removed from the SGIP project itself.

#### **4.2.2 Changes in Utilization over Time**

To estimate changes in capacity and utilization trends we collected capacity data from PAs for all program projects, their technologies and fuel types, and the dates of their addition to the program. We also collected a vast set of project-specific utilization data from a large sample of program projects. Utilization data include electric net generation output metered by us and data provided to us but metered by others. For some unmetered projects we also have collected qualitative information on utilization.<sup>4</sup> From these capacity and utilization data we estimate program impacts.

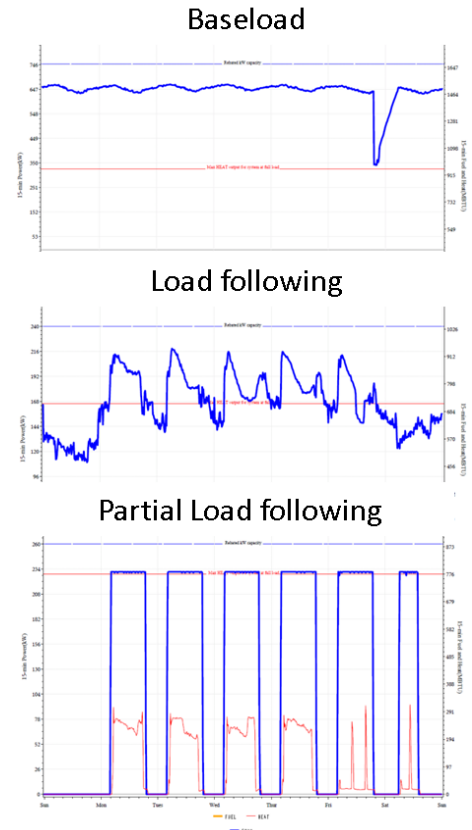
---

<sup>3</sup> Electric loads alone matter for projects that do not recover heat, while electric and thermal loads both matter for projects that recover heat.

<sup>4</sup> Appendix C describes data sources and analysis in detail.

Program electric demand impacts are time sensitive, occurring during peak system demand hours. Thus both the timing and extent of capacity utilization are important. To recognize both we describe utilization throughout this section in terms of capacity factors for specific time periods.<sup>5</sup> We also describe utilization trends in terms of changes in the timing and extent of capacity used by the different technologies in the program.<sup>6</sup> We look at utilization trends over program years but more importantly over project ages. While each year the program adds new capacity that might deliver additional impacts, existing capacity continues to age. Some older projects have reduced or completely stopped utilizing their generating capacity and no longer deliver the impacts they had earlier.

Technology utilization trends focus on capacity factors as essential measures of performance in delivering impacts, but as performance indicators they must be used with caution. Capacity factors allow direct comparisons of utilization between different capacities, different technologies, and different times. But capacity factors must not be used as definitive measures of performance. Capacity factors arise from generating schedules that may change from season to season for an individual project or be vastly different between different projects (see sidebar). And despite the different capacity factors that can result, these different generation schedules may deliver impacts identically suitable to the facility.



A wide range exists in generation schedules. Project participants choose when and how much SGIP generation they use to meet on-site electricity demands. Utilization may vary widely, as shown by these data from 3 actual projects. Thin horizontal blue lines show project capacity; thick blue lines, changing output power. Among SGIP projects to date, baseload is more common utilization among fuel cells and gas turbines, giving them generally higher capacity factors. Partial load or load following are more common among IC engines and microturbines, giving them lower capacity factors. Due to widely different utilization choices, capacity factors must be used cautiously as performance indicators.

<sup>5</sup> Capacity factors indicate the fraction of energy actually generated during a time period relative to what would have been generated if generation were at full capacity over the period. Capacity factors are always specific to a time interval (e.g., hourly, monthly, annual). Hourly capacity factors during peak demand hours are key indicators of demand reducing performance. Annual capacity factors are another key performance indicator but must be viewed with reference to generation schedules.

<sup>6</sup> This section does not include wind technology due to lack of metered data from the 10 projects completed by the end of 2011.



### 4.3 Technology Utilization Trends

#### 4.3.1 Overview of Program Capacity by Technology

Program impacts depend on the utilization of the program capacity composed of the many program projects. We begin this discussion of technology utilization trends by discussing the composition of program capacity by technology.<sup>7</sup> We grouped project capacities by common technology type and fuel type to identify technology utilization trends. Figure 4-1 demonstrated the changing technology and fuel composition of the aggregate program capacity from 2001 to 2011. Figure 4-2 shows the annual capacity additions from 2001 to 2011 by technology as they contributed to those aggregates.

**Figure 4-2: Annual Capacity Additions by Technology**

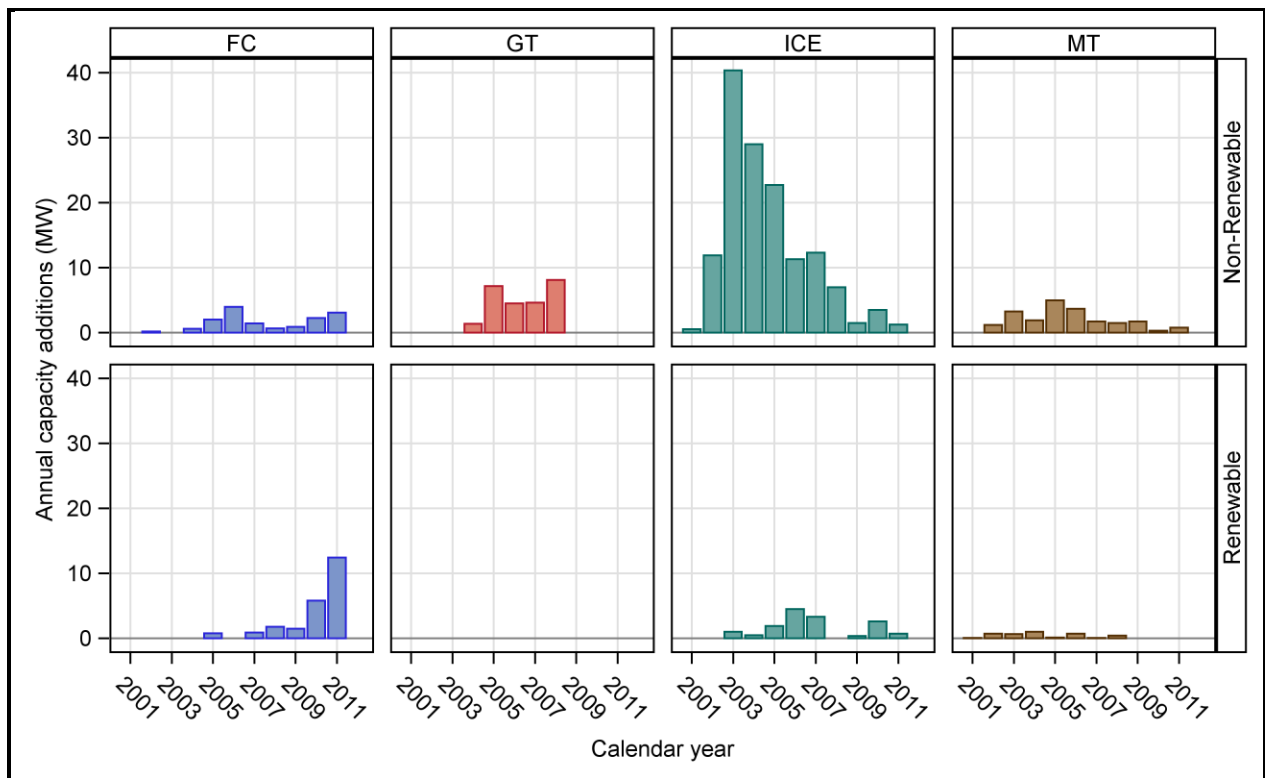


Figure 4-2 shows that ICE-N has been the dominant source of SGIP capacity, with large capacity additions in early program years followed by marked declines thereafter. ICE-N not only included the largest share of program capacity, but also provided the largest share of the program’s oldest capacity. Other technologies have had different program participation histories. Gas turbines (GT) had substantial capacity additions from 2005 to 2008, composed of

<sup>7</sup> For brevity we use ‘technology’ to differentiate prime mover types (FC, GT, ICE, MT) and between combinations of prime mover and fuel types (non-renewable, renewable). Context makes clear whether one or both features are meant.

small numbers of multi-megawatt projects. Renewable fuel cell (FC-R) capacity surged in 2011. Much of that added capacity represented directed biogas FC-R projects that actually consumed natural gas. This FC-R capacity was much younger than almost all other program capacity.

**Figure 4-3: Mean Ages of Program Aggregate Capacities by Technology**

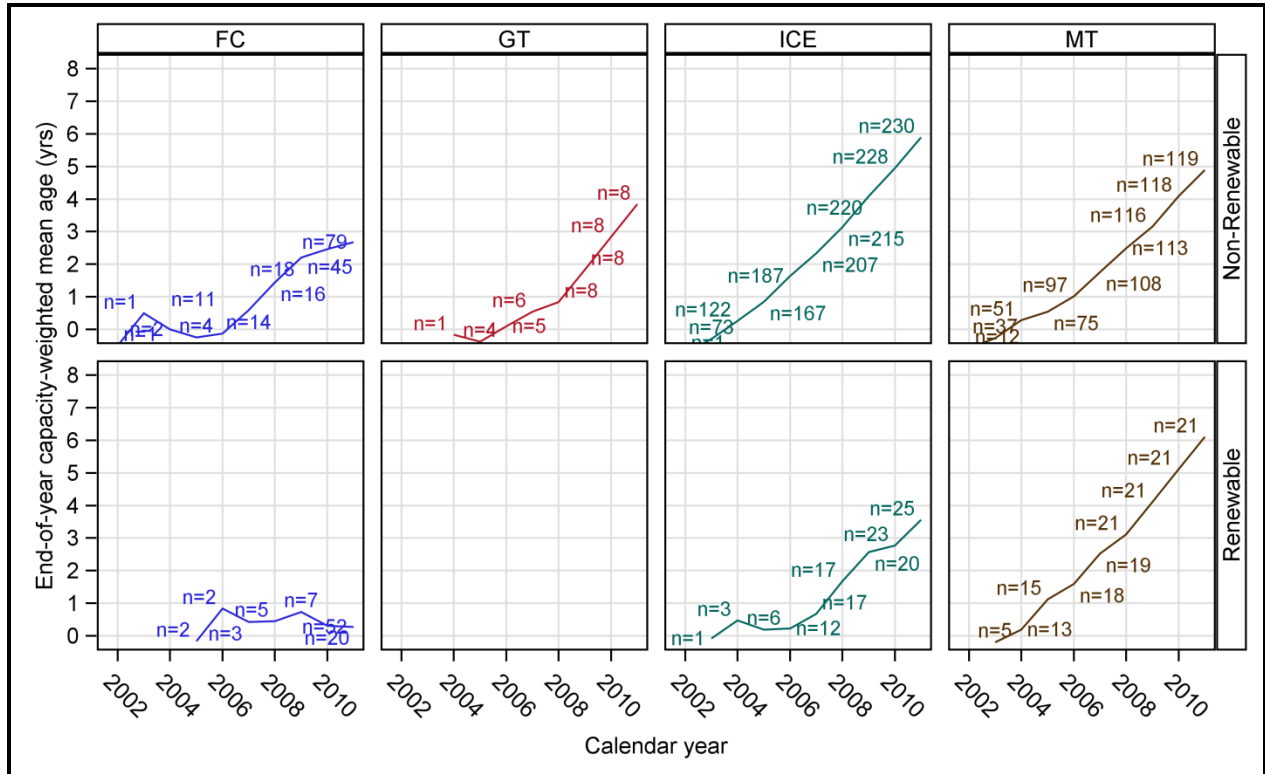


Figure 4-3 shows trend in the capacity-weighted mean age of the technology populations from 2002 to 2011. The trend lines include population project counts in the program at the end of each calendar year. The mean ages as well as the numbers in the ICE-N population have been both the highest and growing for almost every year. The mean age of FC-R, on the other hand, has fallen as its population surged in 2011. The mean ages of FC-R have been remarkably flat due to influxes of new projects in later program years. Meanwhile non-renewable fuel cells (FC-N) and renewable IC engines (ICE-R) have remained somewhat young relative to other technologies due to their slower adoption in early program years.

### 4.3.2 IC Engine Utilization Trends

We begin discussion of utilization trends with ICE-N because ICE-N represents the single largest technology contributing capacity to the SGIP. As such, ICE-N utilization trends have the greatest effect on program impacts. The decline in the utilization of their older capacity has led to declines in some program electric impacts even as their capacity has grown. We also discuss

utilization trends for non-renewable microturbines (MT-N), GT, and FC-N. Similar charts for the remaining technologies can be found in Appendix A.

There was a marked tendency for utilization of ICE-N to decrease with increasing age. One important factor contributing to this trend was the increasing incidence of off-line<sup>8</sup> projects. Figure 4-4 presents the incidence of these idle projects with yellow bars and the declining utilization with the solid black line of capacity-weighted mean annual capacity factors.<sup>9</sup>

**Figure 4-4: ICE-N Annual Capacity Factor and Project Age**

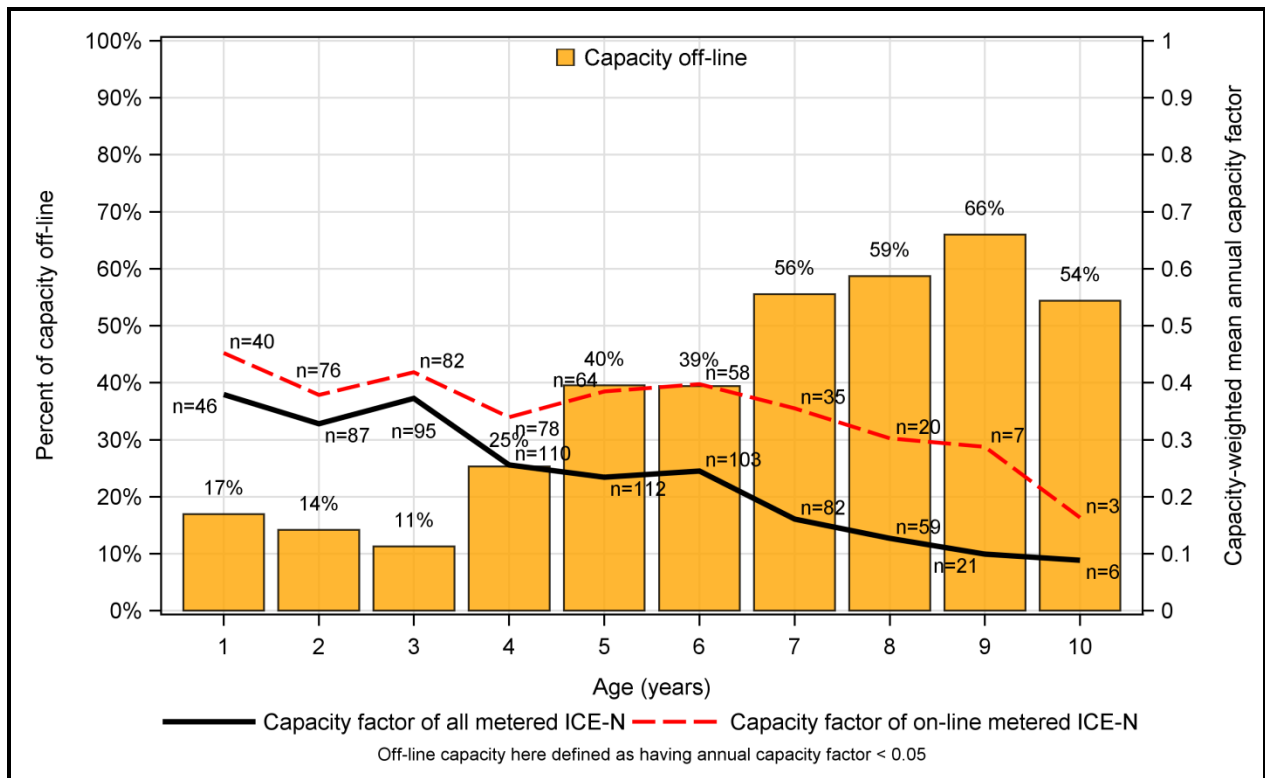


Figure 4-4 shows that 54% to 66% of project capacity between 8 to 10 years in age was off-line. Conversely, only 11% to 17% of project capacity less than three years in age was off-line. Clearly aging can contribute to increase off-line status and a commensurate downward trend in overall capacity-weighted average capacity factor with time. The solid black line in Figure 4-4

<sup>8</sup> Off-line projects are projects that are generating electric energy below a minimum capacity factor for a specific period. In Figure 4-4 the minimum is an annual capacity factor of 0.05. Among off-line capacity may be decommissioned projects that have been disassembled and removed from the project site.

<sup>9</sup> A capacity weighted mean value takes the capacity of the technology into account. Consequently, larger projects have a greater influence on the mean value being calculated. Capacity factor refers to the fraction of energy actually generated during a time period relative to what would have been generated if generation were at full capacity over the period. A capacity-weighted mean annual capacity factor then is an average annual performance metric for the population of projects weighted by the capacities of the projects.

summarizes overall performance of all projects regardless of their operational status. The dashed red line depicts capacity-weighted average capacity factor only of capacity that was on-line during a given year. If the performance of on-line projects was unchanged through time this dashed red line would be horizontal. We see in Figure 4-4 that while performance of on-line capacity tends to be approximately steady for the first six years, after that, performance diminishes with further increases in age. This trend suggests that on-line projects reaching ages 7-10 may be more affected than younger projects by some factors that can reduce utilization of capacity.

The decline in utilization of the program population of ICE-N has more than offset its capacity growth. Their annual energy impacts have declined as a result. Figure 4-5 shows the estimated annual energy impacts (in gigawatt-hours on the left axis) and end-of-year capacity totals (in MW on the right axis) of ICE-N from 2002 to 2011.

**Figure 4-5: ICE-N Annual Energy Impact and End-of Year Aggregate Capacity**

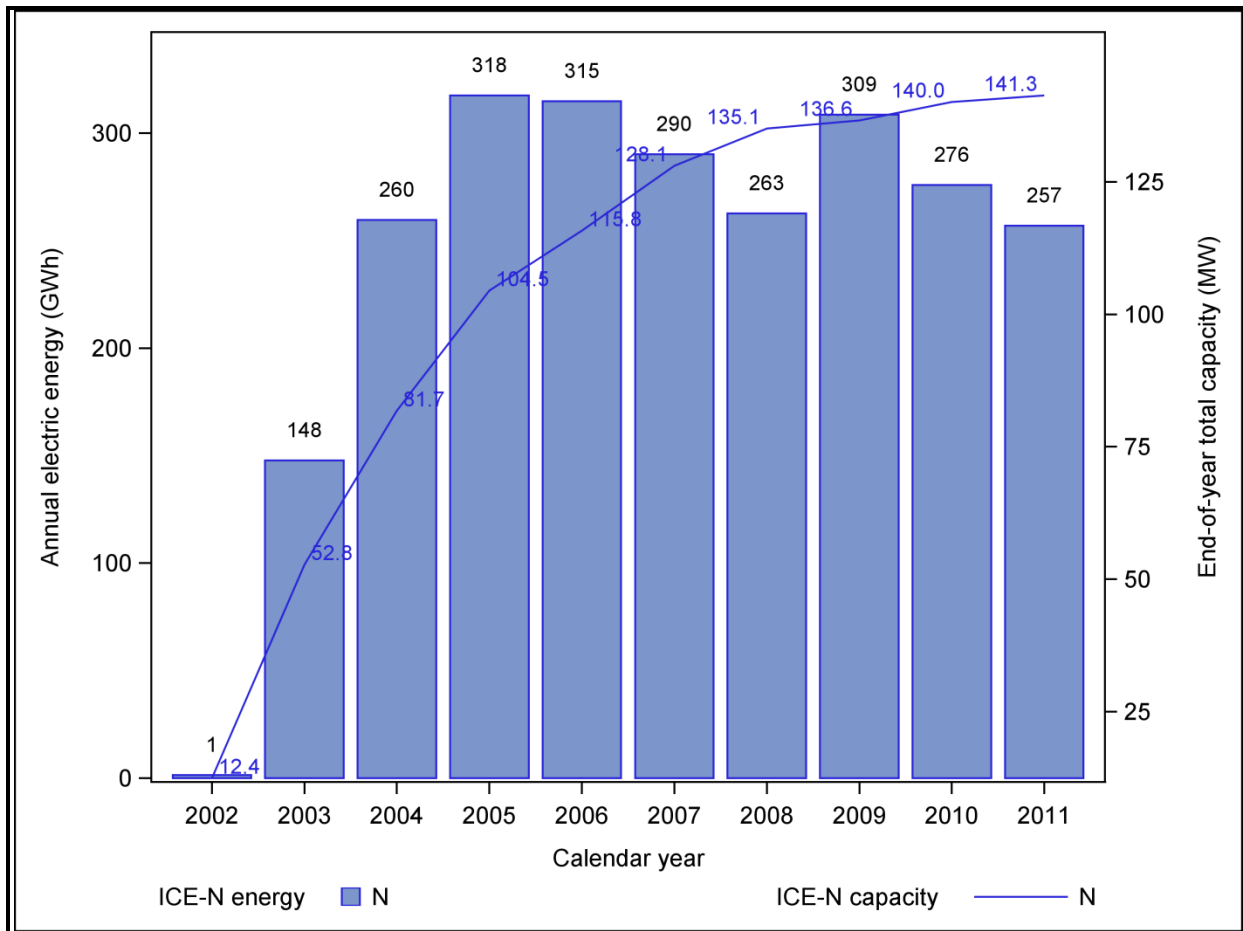
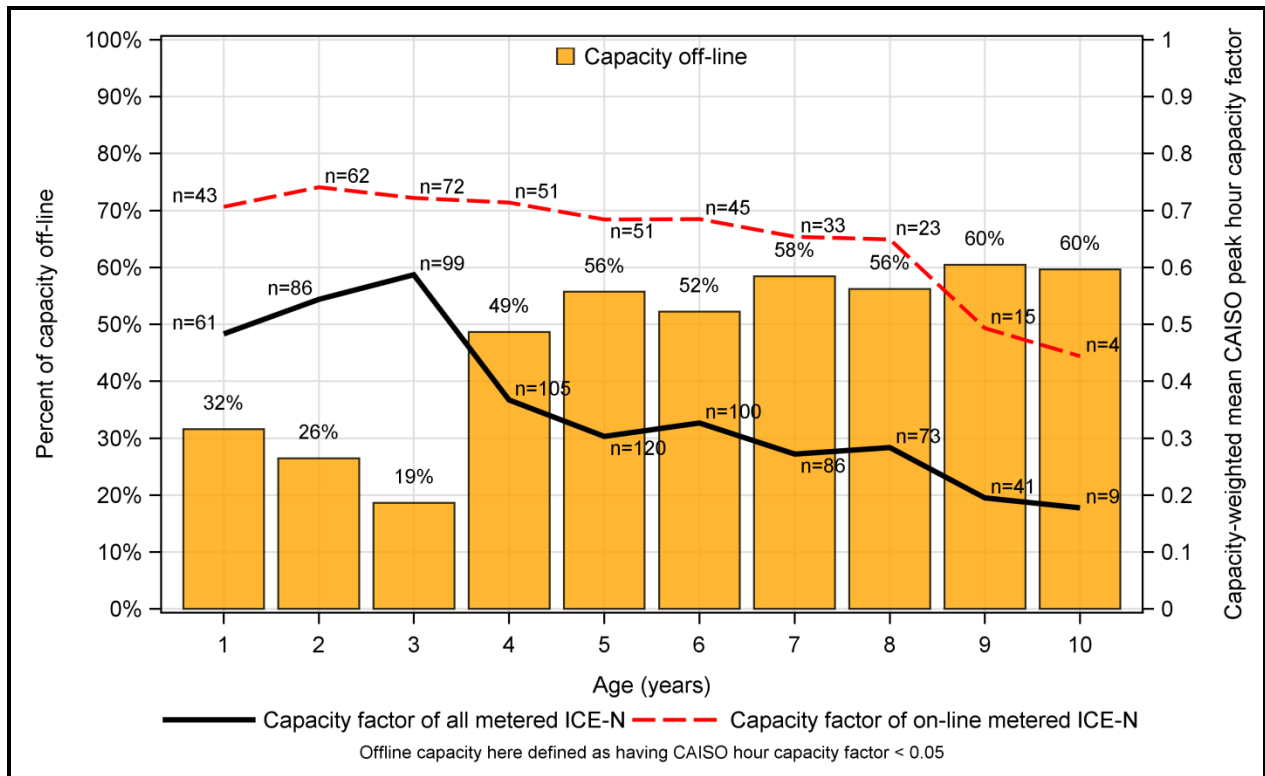


Figure 4-5 shows a flattening after 2005 in the annual energy impacts from ICE-N. Although total capacity grew 35% from 2005 to 2011, the decline in overall utilization prevented similar growth in energy impacts.<sup>10</sup>

The decline with age in utilization of ICE-N also contributed to a decline in their demand impacts during CAISO peak hours. Figure 4-6 shows the capacity-weighted mean capacity factors of metered ICE-N projects during CAISO peak hours for projects 1 through 10 years in age.

**Figure 4-6: ICE-N CAISO Peak Hour Capacity Factor and Project Age**



Declining utilization during the CAISO peak hour is shown by the solid black line in Figure 4-6. The solid black line summarizes overall performance of all metered projects regardless of their operational status during the CAISO peak hour. The dashed red line depicts capacity-weighted mean capacity factor of only projects that were on-line during those hours. Consistent with Figure 4-4, Figure 4-6 also shows yellow bars of percentage of capacity that is off-line. A

<sup>10</sup> Periods of low spark spread for ICE-N occurred between 2005 and 2009 as natural gas prices rose, potentially reducing utilization during that period. Spark spread then returned to pre-2005 levels. See Figure F-3: Alternative CHP Spark Spread by Technology (2001–2010), in CPUC Self-Generation Incentive Program Tenth-Year Impact Evaluation Final Report, Submitted to PG&E and the Self-Generation Incentive Program Working Group, July 7, 2011.

project is considered off-line if its CAISO peak hour capacity factor is less than 0.05.<sup>11</sup> As with annual capacity factors in Figure 4-4, we see in Figure 4-6 that on-line capacity maintains its CAISO peak hour capacity factor up to 8 years in age. CAISO peak hour utilization diminishes more sharply with further increases in age. This trend suggests that on-line projects older than 8 years in age may be more affected than younger projects by factors that can reduce utilization.

Off-line capacity includes projects that may come on-line again and projects that have been permanently decommissioned. The former group may be expected to deliver future program impacts. Decommissioned projects by their very nature cannot have program impacts. For that reason, we distinguish decommissioned capacity from off-line capacity.

**Figure 4-7: 2011 ICE Retired Capacity by Project Vintage**

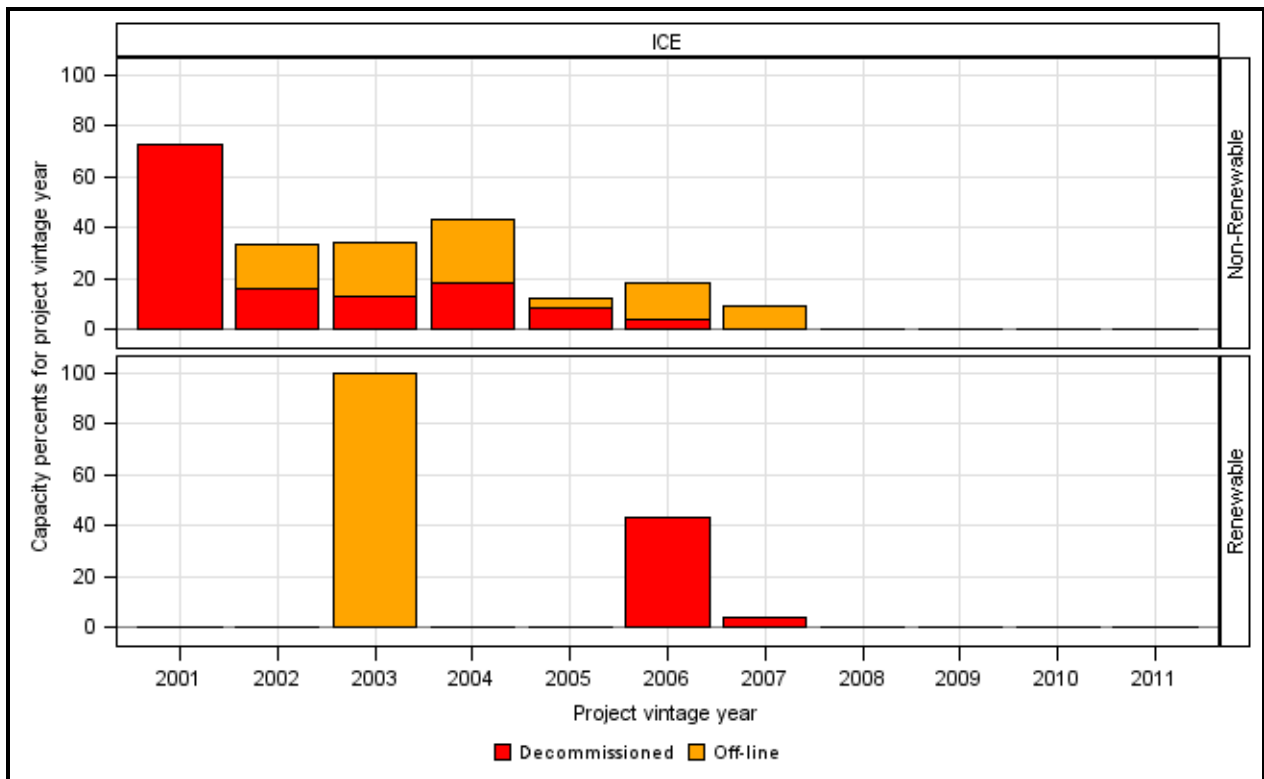


Figure 4-7 demonstrates how percentages of decommissioned capacity and off-line capacity change with capacity age for renewable and non-renewable IC engines. The axis at the left shows the percentage of capacity that was decommissioned or off-line as of the end of 2011.<sup>12</sup> The horizontal axis refers to project vintage year. The project vintage year represents the age of

<sup>11</sup> A greater minimum value might be used for hourly than for annual capacity factor given relative ease of dispatching non-renewable distributed generations for afternoons during peak periods rather than whole years. Only small differences in percentages considered off-line occur unless the minimum is raised above 0.3.

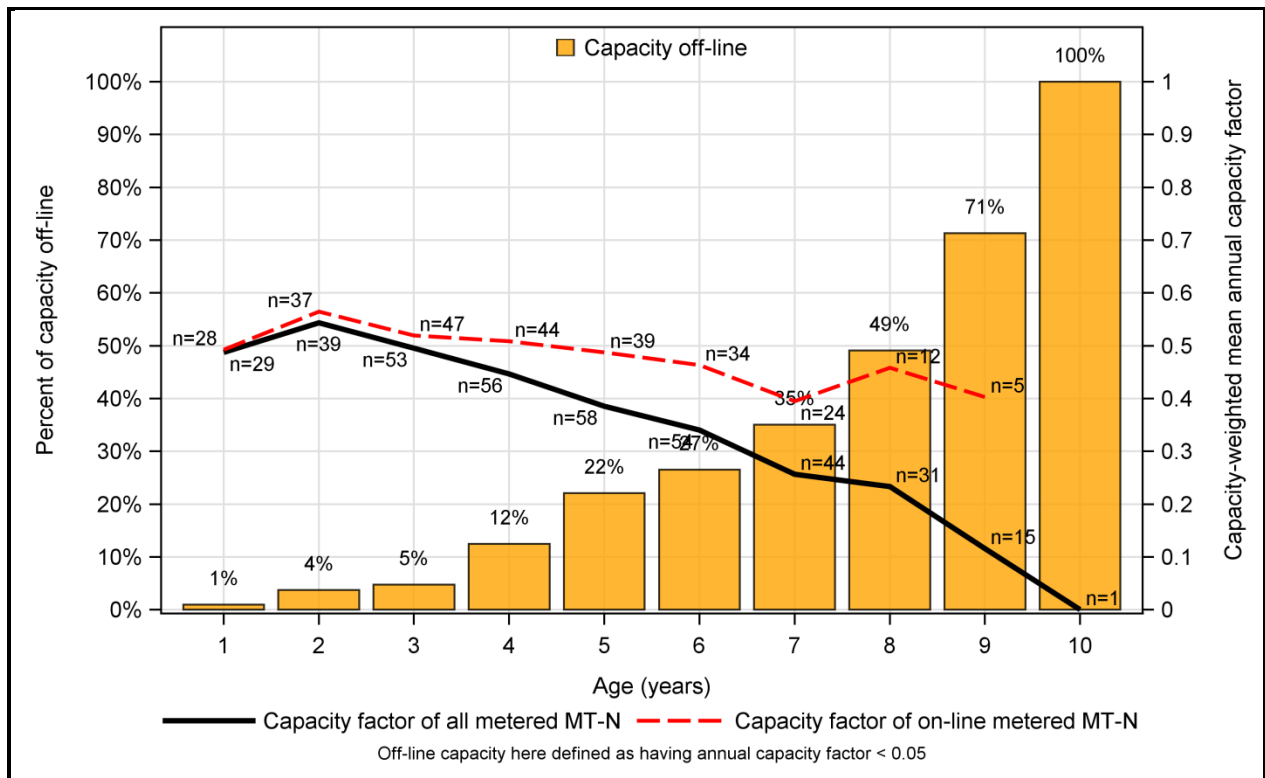
<sup>12</sup> As before, off-line is defined as having 2011 annual capacity factor less than 0.05.

the particular vintage of projects from when the vintage had been installed. For example, by the end of 2011, projects installed in 2001 (project vintage year of 2001) would be considerably older than projects installed in 2006 (project vintage year of 2006). As would be expected, at the end of 2011, earlier project vintages showed that greater percentages of ICE-N were decommissioned or off-line than from later project vintages. The percentages in Figure 4-7 for ICE-R suggest a different trend but are less representative of ICE as the number of ICE-R projects is much smaller than of ICE-N.

### 4.3.3 Microturbine Utilization Trends

Another technology that entered the program in large numbers in early program years was non-renewable microturbines (MT-N). Figure 4-8 shows a utilization trend for MT-N similar to that seen for ICE-N.

**Figure 4-8: MT-N Annual Capacity Factor and Project Age**



The yellow bars of Figure 4-8 represent the amount of off-line MT-N capacity. The growth in the yellow bars indicates that an increasing amount of MT-N capacity goes off-line with increasing age of the project. This growth in off-line capacity is slower than seen for ICE-N, with the percentage of off-line capacity exceeding 10% in ages 1 through 3 and increasing above 55% by age 7. Figure 4-8 shows a single MT-N at age 10, suggesting the 100% capacity off-line bar may not be representative of what will be observed when larger numbers of projects reach

this age. Indeed, the dashed red line (which represents the mean capacity factor of the MT-N on-line projects) shows that at 9 years in age, 5 of 15 metered projects were still on-line with a mean annual capacity factor of 0.4. These five projects may fare better in their 10<sup>th</sup> year than the oldest metered MT-N project.

Although the percentages of off-line capacity grew steadily with age, the red-dashed trend line for on-line projects suggests that MT-N projects continue to be utilized at relatively high rates despite advancing age. This suggests that factors that reduce MT-N capacity as the projects age may also act to significantly reduce utilization. Conversely, MT-N projects that remain on-line as they age may show utilization similar to that observed during their initial years of operation.

**Figure 4-9: MT-N CAISO Peak Hour Capacity Factor and Project Age**

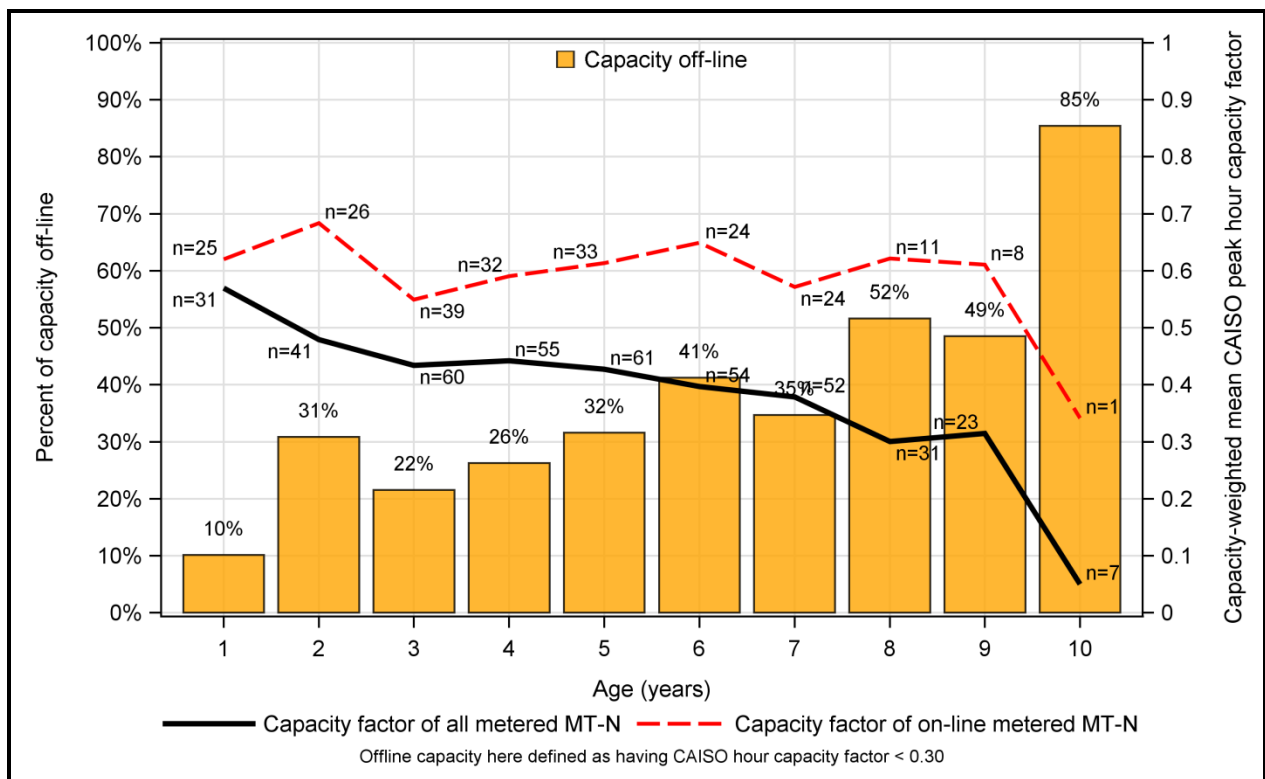


Figure 4-9 shows age trends for MT-N capacity utilization during CAISO peak hours. The progression in growth of off-line capacity was slower than seen for ICE-N. CAISO peak hour capacity factors remained above 0.4 until age 6 for MT-N whereas it fell below that by age 4 for ICE-N. Both technologies maintained utilization fairly well with age among the capacity that was on-line. On-line ICE-N had capacity factors above 0.7 until age 5 and above 0.6 until age 8. On-line MT-N had capacity factors above 0.6 for most years until age 9 when they fell sharply.



Both ICE-N and MT-N technologies in the SGIP have commonly been observed operating with load following or partial load following generation schedules. Historically, this has led them to have similar observed capacity factors.<sup>13</sup> This differentiates them from SGIP FC and GT technologies that commonly have been observed to have baseload generation schedules and subsequently greater capacity factors. Figure 4-3 also showed ICE-N and MT program capacities to have similar mean age trends over the course of the program. But Figure 4-6 and Figure 4-9 showed that ICE-N and MT had different CAISO peak hour utilization with age. This difference distinguished their 2011 program demand impacts. Figure 4-10 shows their estimated mean hourly capacity factors during the 2011 CAISO peak day along with those of GT-N and FC-N.

**Figure 4-10: 2011 CAISO Peak Day Hourly Capacity Factors**

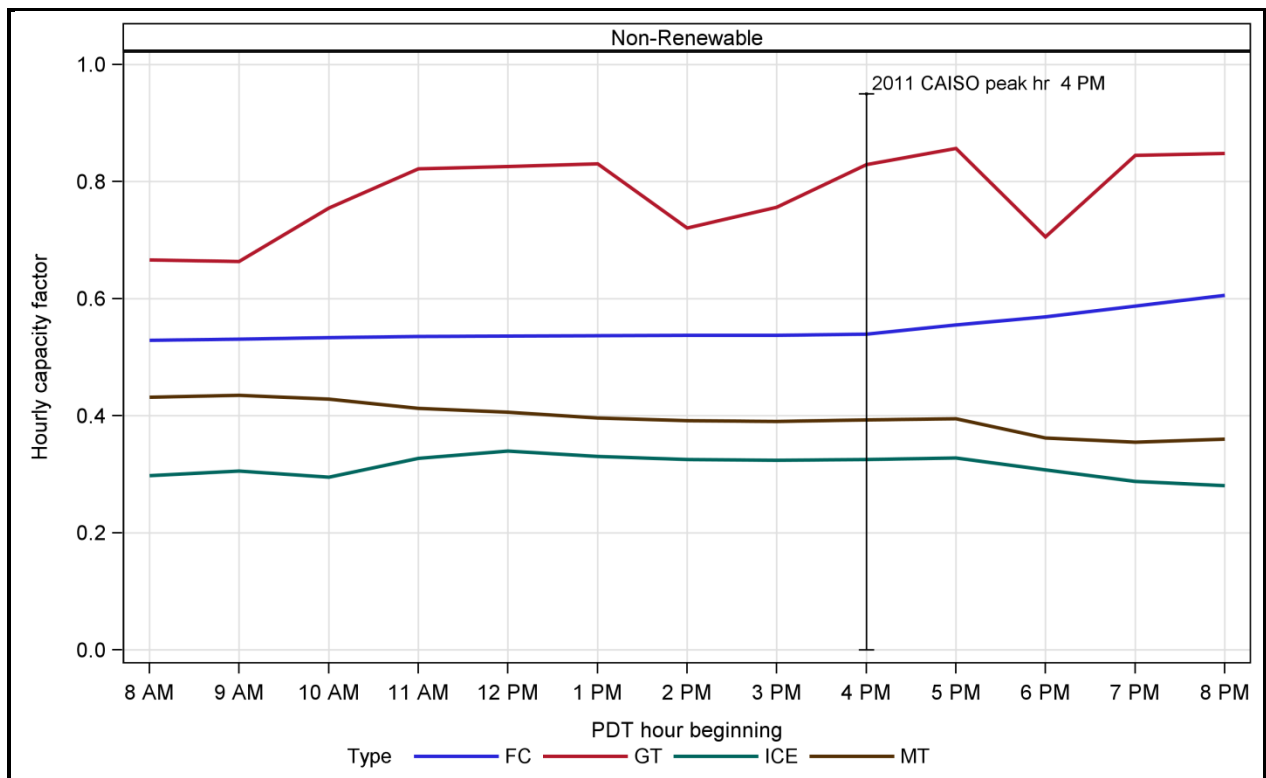


Figure 4-10 shows MT-N capacity had greater utilization than ICE-N capacity throughout the middle of the 2011 CAISO peak day. At the peak hour the mean hourly capacity factor was 0.39 for MT-N capacity and 0.33 for ICE-N. MT-N capacity utilization was 18% higher than ICE-N utilization. Small improvements in the peak hour capacity factor of ICE-N can contribute large

<sup>13</sup> We expect that projects coming into the SGIP under a performance based incentive could operate significantly differently than their counterpart technologies in the past.

gains to demand impacts since ICE-N capacity is 57% of total program capacity as of the end of 2011.

### 4.3.4 Gas Turbine Utilization Trends

Utilization trends for gas turbines (GT-N) and non-renewable fuel cells (FC-N) were distinctly different from those for ICE-N and MT-N. As mentioned earlier, baseload generation schedules are more common to GT and FC than to ICE and MT. GT and FC therefore have greater utilization generally. Program populations of GT-N and FC-N were also smaller in capacity and later in entering the program than those of ICE-N and MT-N, as shown in Figure 4-2. This relative youth increases the likelihood of smaller percentages of their capacities being off-line in 2011. Figure 4-11 and Figure 4-12 show utilization trends for GT-N and FC-N respectively.

**Figure 4-11: GT-N Annual Capacity Factor and Project Age**

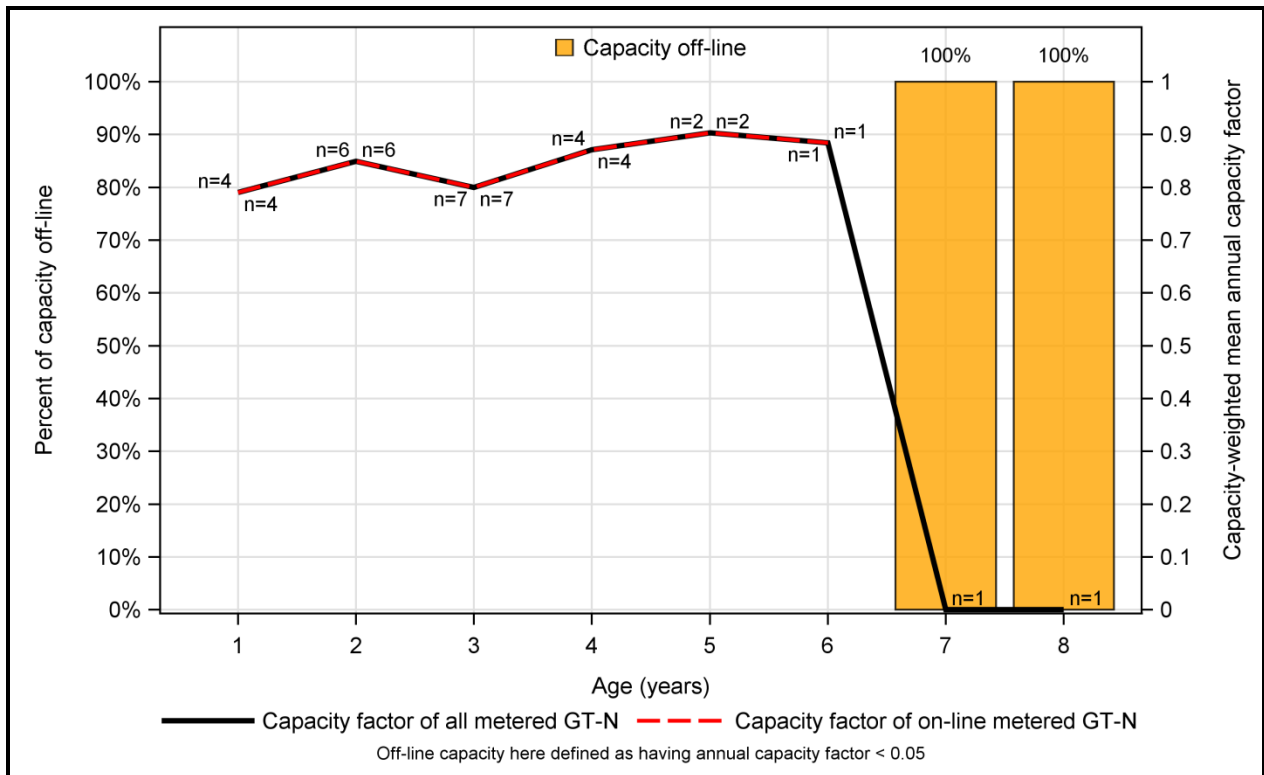


Figure 4-11 shows small numbers of metered GT-N projects with mean annual capacity factors regularly above 0.8 up to age 6. It shows that only one metered GT-N reached beyond age 6, and at age 7 its capacity went off-line. That capacity is 100% of GT-N capacity at ages 7 and 8. The solid black and dashed red lines are overlaid in Figure 4-11 up to age 6. This indicates that all metered GT-N also were on-line through age 6. Annual utilization of GT-N capacity is generally twice that of ICE-N. This means that on a per-unit of capacity basis GT-N projects generally have provided twice the annual program energy impacts of ICE-N. All else equal, a unit of GT-

N has delivered greater energy impacts than a unit of ICE-N or MT-N. Because they already maintain higher utilization, to age 6 at least, GT-N have less potential than ICE-N and MT-N to increase annual energy impacts through any potential program efforts that might encourage increased capacity utilization.

The small numbers of GT-N at ages above 4 suggest their utilization may not be representative of GT-N generally. It remains to be seen whether utilization of current GT-N program capacity will continue with capacity factors above 0.8 beyond age 6.

### 4.3.5 Fuel Cell Utilization Trends

Figure 4-12 shows annual utilization trends for FC-N program capacity. It shows large numbers of FC-N projects at 1 year in age. These year 1 age counts contributed to the relative youth of FC-N program capacity in 2011. Annual utilization among these newer FC-N projects was also high, with mean annual capacity factor above 0.8. Utilization fell rather quickly as the mean age of FC-N program capacity increased. This fall included on-line capacity. Relatively small percentages of FC-N capacity were off-line from ages 1 to 6 compared to the same ages for ICE-N and MT-N. Their contributions to the fall in utilization then also were relatively small. That annual utilization among on-line FC-N capacity fell after age 1 suggests the likelihood that CAISO peak hour capacity factor also may have fallen at that age.

**Figure 4-12: FC-N Annual Capacity Factor and Project Age**

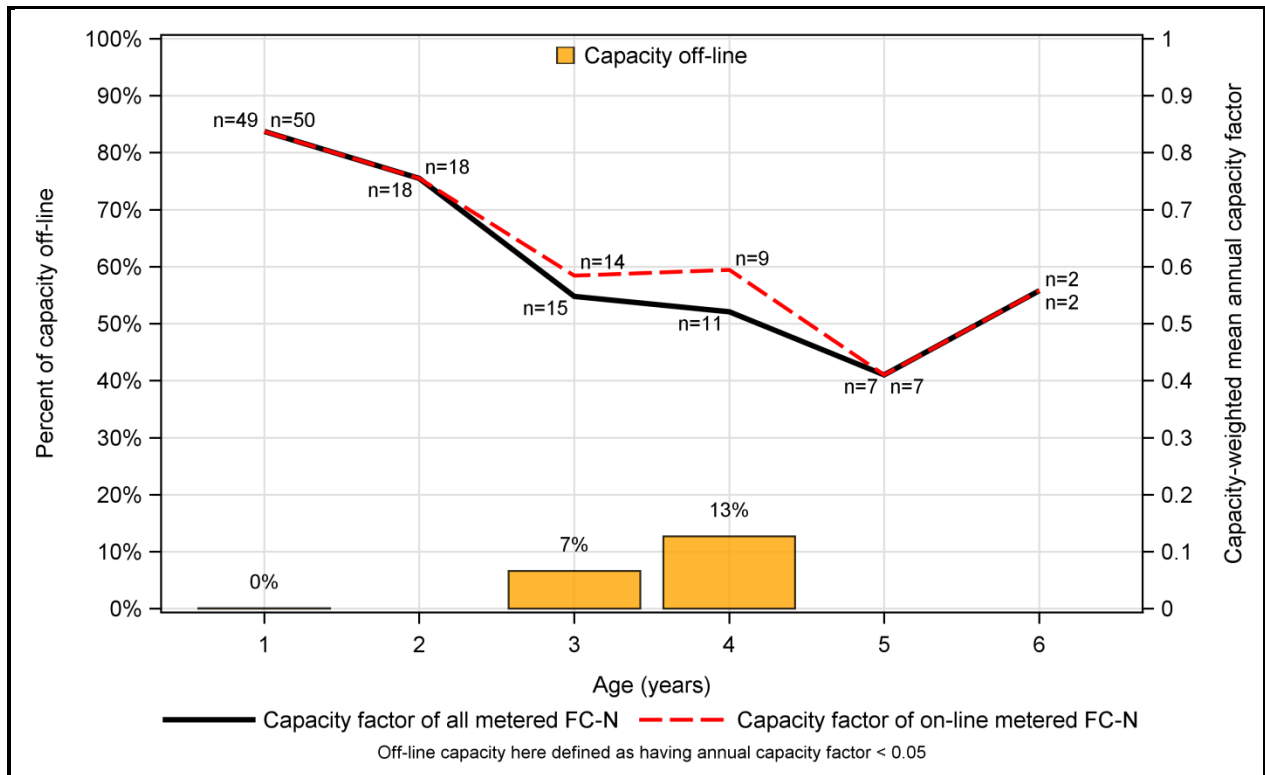


Figure 4-13 shows the capacity-weighted mean capacity factors of metered FC-N projects during CAISO peak hours for projects aged 1 through 7. Figure 4-13 shows CAISO peak hour FC-N capacity utilization fell less sharply at ages 2 and 3 than did annual utilization. Thus peak hour program demand impacts from FC-N capacity likewise fell less sharply. But Figure 4-13 also shows the percentage of FC-N capacity off-line at age 1 was 14%. This detracted from the high peak hour utilization of on-line capacity that had mean capacity factor above 0.9. High peak hour capacity factors such as these are indicators of program success in reducing peak demand.

**Figure 4-13: FC-N CAISO Peak Hour Capacity Factor and Project Age**

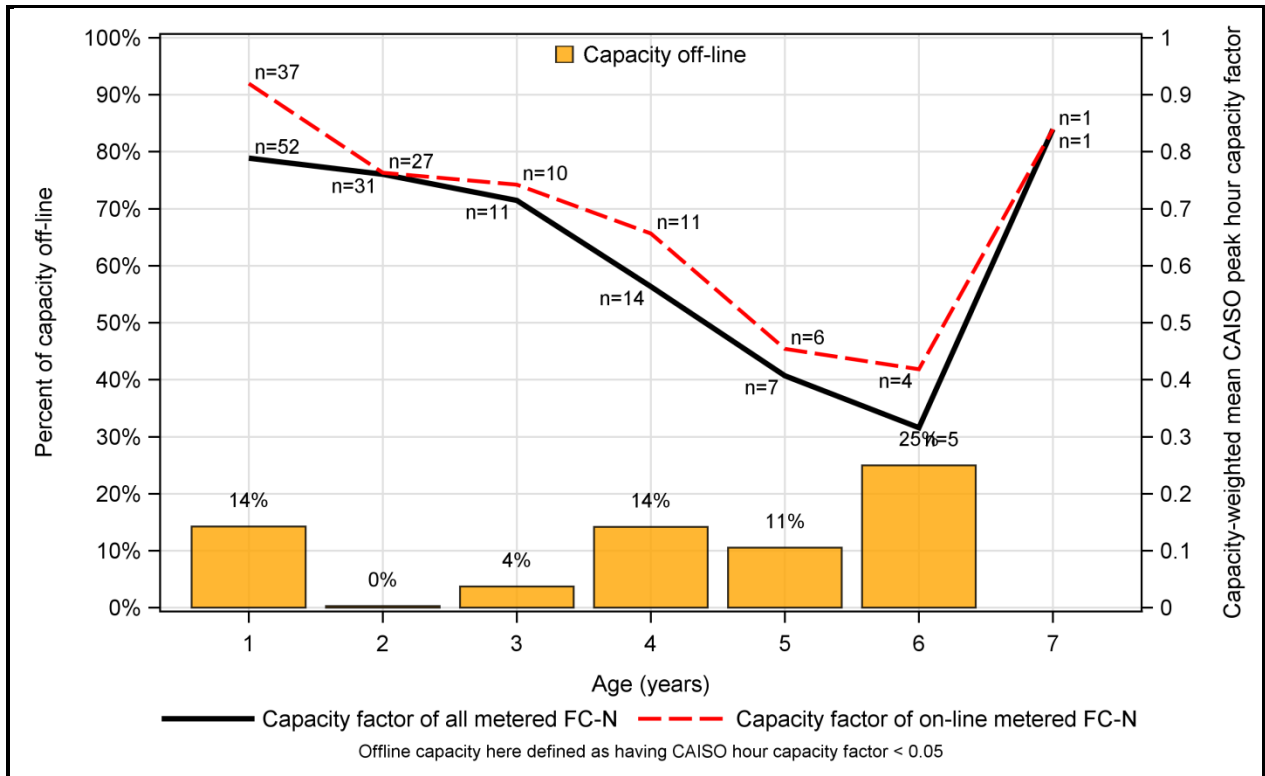


Figure 4-13 shows rapid declines after 3 years of age in CAISO peak hour capacity utilization for both overall and on-line FC-N program capacity. By age 6 this utilization reaches an hourly capacity factor of 0.3. This is on par with ICE-N program capacity at age 6, a technology whose generation schedules lead it to have lower capacity factors in general. This comparison between FC-N and ICE-N is not complete without also noting that 52% of ICE-N program capacity, over twice that of FC-N program capacity, was off-line during peak hours at age 6.

The sharp rises in utilization at age 6 in Figure 4-12 and age 7 in Figure 4-13 arose from a pair and a single FC-N project respectively. As such they should not be considered representative of FC-N program capacity generally or of the futures of younger FC-N program projects.

### 4.3.6 Program Annual Capacity Factor Trends

Program capacity utilization trends have changed with the program’s technology capacity composition, the changing ages related to those capacities, and with fluctuations in energy prices. Figure 4-14 shows the progression of these changes for all program technologies from 2002 to 2011 in terms of their capacity-weighted mean annual capacity factors by year.

**Figure 4-14: Calendar Year Annual Mean Capacity Factors**

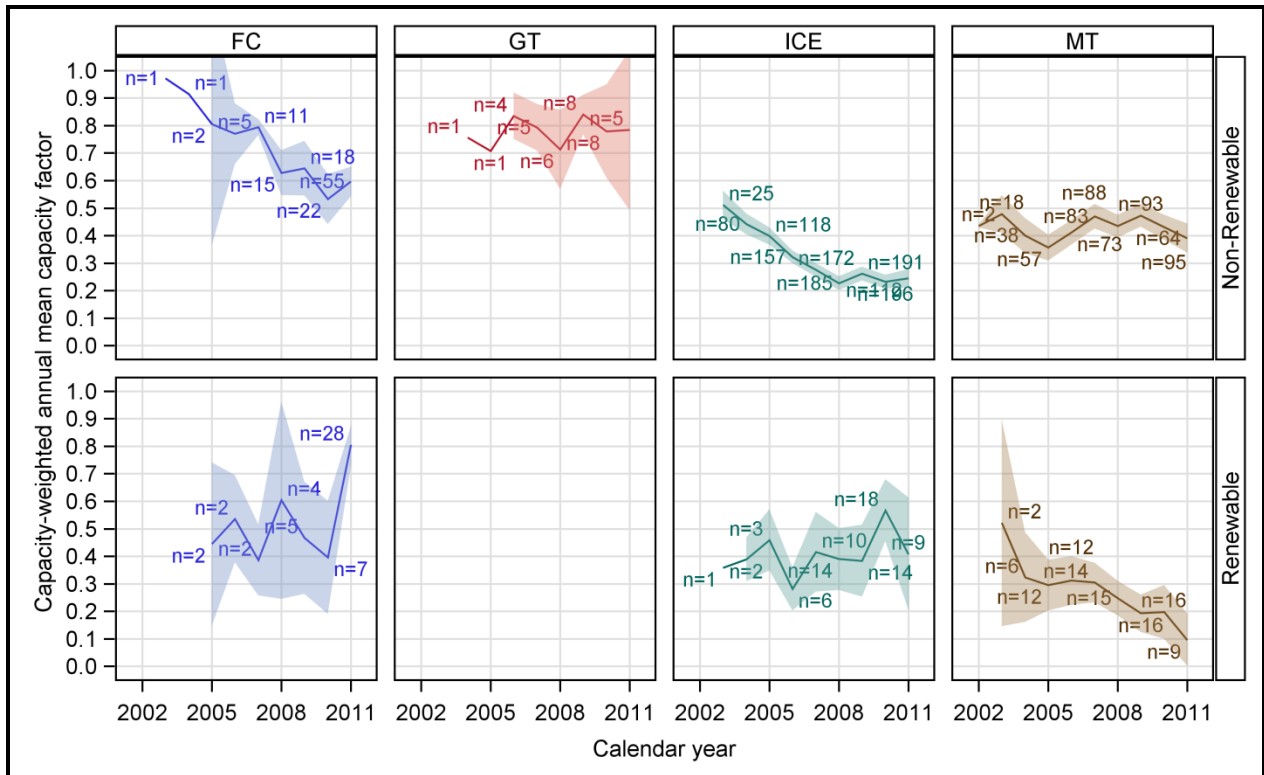
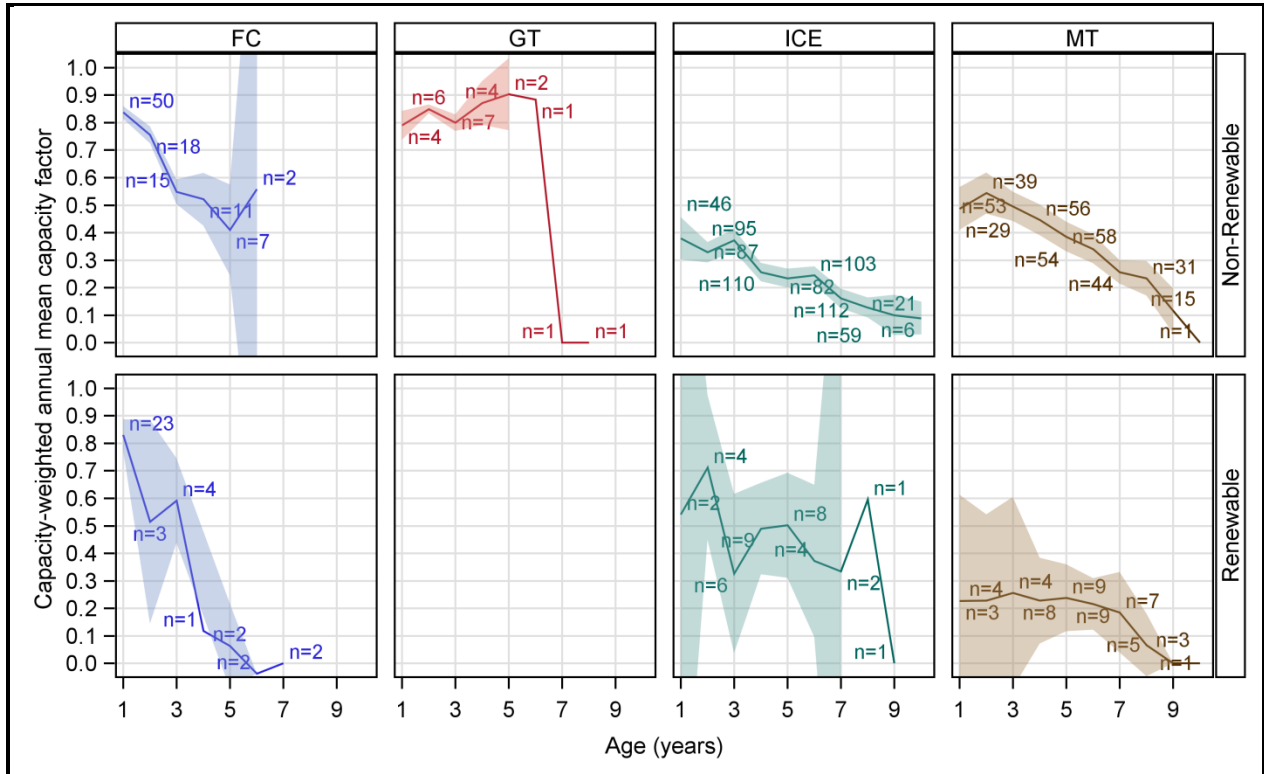


Figure 4-14 displays non-renewable technologies in the upper row and renewable in the lower row. The solid lines indicate the capacity-weighted annual mean capacity factors from metered projects. The shaded bands around the solid lines indicate upper and lower ranges of the uncertainty of these means based on 90/10 confidence limits. The n-values indicate the count of metered projects that contributed to each point. Projects included in the calculations had metered data for at 70% of the calendar year. Figure 4-14 shows that until 2010, FC-R, ICE-R, and MT-R had lower annual capacity factors than their non-renewable counterparts. In 2010, the renewable fuel category began to include directed biogas projects that consume natural gas. Steady natural gas supplies allow directed biogas systems to avoid biogas supply sensitivities that could affect on-site renewable fuel projects and lead to lower annual capacity factors. In 2011, 43 of the 129 FC in the program were directed biogas FC-R that had come online since late 2010. Combined

with relief from on-site biogas supply sensitivities, these new projects helped raise the annual capacity factor of FC-R.

Figure 4-15 shows the progression of utilization for all program technologies in terms of their capacity-weighted mean annual capacity factors by age, again with non-renewable in the upper row and renewable in the lower row.

**Figure 4-15: Mean Annual Capacity Factor Trends with Age**



With the exception of ICE-R, Figure 4-15 indicates a clear declining trend in annual capacity factor with age. The decline is particularly precipitous for FC in the first three years. The rapid declines at older ages in several of the charts are attended by small numbers of metered projects. Because of the small numbers associated with these older projects, their annual capacity factors should not be taken to represent the futures of younger systems of later vintages.

#### 4.4 Program Impact Trends

This section provides summaries of estimated program electric impact trends. We begin with program demand impacts and follow with program energy impacts. Appendix A provides additional detail on these impacts, distinguishing impacts on the basis of metered versus estimated values as well as by technology.

#### 4.4.1 Demand Impacts

Program demand impacts are the average hourly power generated by program capacity during peak demand hours. We use generation coincident with the CAISO annual peak hour as the chief indicator of program demand impacts. Other indicators include non-coincident generation during other hours of high CAISO demand. We address demand impacts coincident with the annual peak hours of the 3 investor-owned utilities that serve program projects in the section on Program Administrator impact trends.

The 2011 CAISO peak load of 45.6 GW occurred Wednesday, September 7, between 4 p.m. and 5 p.m. Pacific Daylight Time. CAISO annual peak hours typically occur during late weekday afternoons between July and early September. Figure 4-16 shows these peak demands over the course of the program. The 2011 peak was the lowest since 2005.

**Figure 4-16: CAISO Annual Peak Hours from 2002 to 2011**

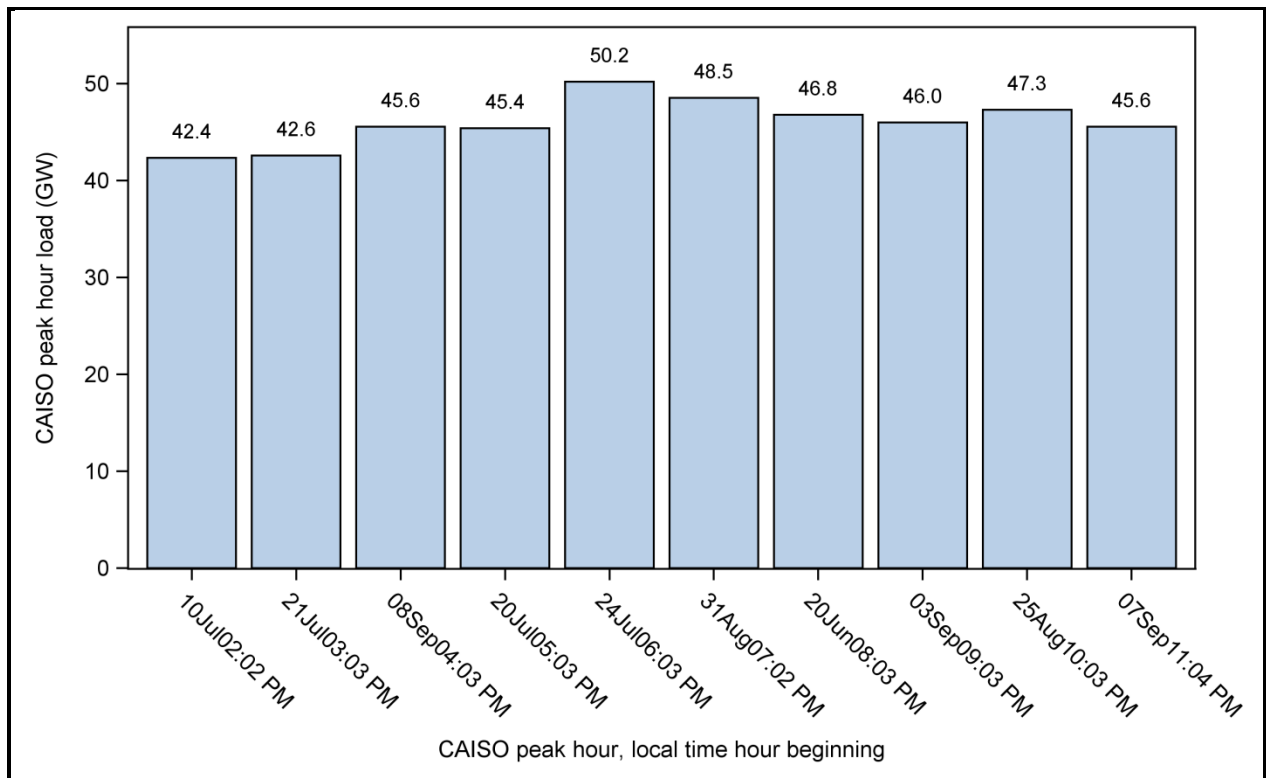


Table 4-1 lists 2011 peak hour project counts, associated total capacities, estimated impacts, and associated hourly capacity factors for the four technologies. Counts and capacities differ from those at the end of 2011 where additional capacity was added after the CAISO peak day.

**Table 4-1: 2011 CAISO Peak Hour Impacts and Capacity Factors**

Type	Count (n)	Capacity* (MW)	Impact* (MW)	Capacity factor (kWh/kWh)
FC	113	32	23	0.70
GT	8	26	21	0.83
ICE	254	156	53	0.34
MT	140	25	9	0.35
<b>Total</b>	515	238	105	0.44

\*Totals may not match sums due to rounding.

During the 2011 CAISO peak hour, there were 515 projects in the program with a combined capacity of 238 MW. Their estimated demand impact was 105 MW. The overall program peak hour capacity factor thus was 0.44. This means that on average, SGIP projects in 2011 provided 0.44 MW of peak capacity for each MW of rebated capacity.

As might be expected (given they accounted for 64% of program capacity at the end of 2011), ICE capacity had the largest impact with 53 MW. This was just less than half of the 105 MW total. Table 4-1 also shows the hourly capacity factor of ICE was 0.34. This was less than half the hourly capacity factors for FC and GT. The difference is due in part to differences in generation schedules and in part to the older mean ages of ICE-N and ICE-R program capacities.

GT capacity contributed peak hour demand impacts of 21 MW, 20% of the program total. While GT represented only 11% of program capacity at the end of 2011, their large contribution arose from their high peak hour capacity factor. All else equal, a unit of GT capacity delivered more peak hour demand impact than the other technologies.

FC capacity also had a high peak hour capacity factor. At 0.70 it was 16% below that of GT capacity but still twice that of ICE and MT capacities. As with GT, the difference is due in part to differences in generation schedules and in part to the older mean ages of ICE and MT program capacities.

CAISO peak hour demand impacts have increased in most years as the program has added capacity. Table 4-2 lists CAISO peak hour impacts of overall program capacity from 2002 to 2011.



**Table 4-2: CAISO Peak Hour Impact Trends**

Year	Count (n)	Capacity (MW)	Impact (MW)	Capacity Factor
2002	18	7	1	0.09
2003	89	45	27	0.59
2004	169	84	50	0.60
2005	233	111	68	0.62
2006	304	148	60	0.41
2007	360	176	77	0.44
2008	382	190	70	0.37
2009	406	210	91	0.43
2010	427	217	93	0.43
2011	515	238	105	0.44

Table 4-2 shows that overall program CAISO peak hour capacity factor peaked at 0.62 in 2005 and then fell sharply in 2006. From October 2005 through March 2006 there also was a sharp rise in commercial natural gas market prices in California that discouraged capacity utilization.<sup>14</sup> Capacity factor recovered somewhat in 2007 before falling again in 2008. Natural gas prices were up sharply again from January through October 2008, again discouraging utilization. Since November 2008 commercial natural gas prices in California have remained fairly steady compared to the spikes of 2006 and 2008. Program CAISO peak hour capacity factor meanwhile stabilized over the last three years at the level seen in 2007.

To understand program demand impact trends by technology, Table 4-3 provides overall program CAISO peak hour capacity factors and capacity factors by technology.

<sup>14</sup> Commercial natural gas price histories for California can be viewed at <http://www.eia.gov/dnav/ng/hist/n3020ca3m.htm>

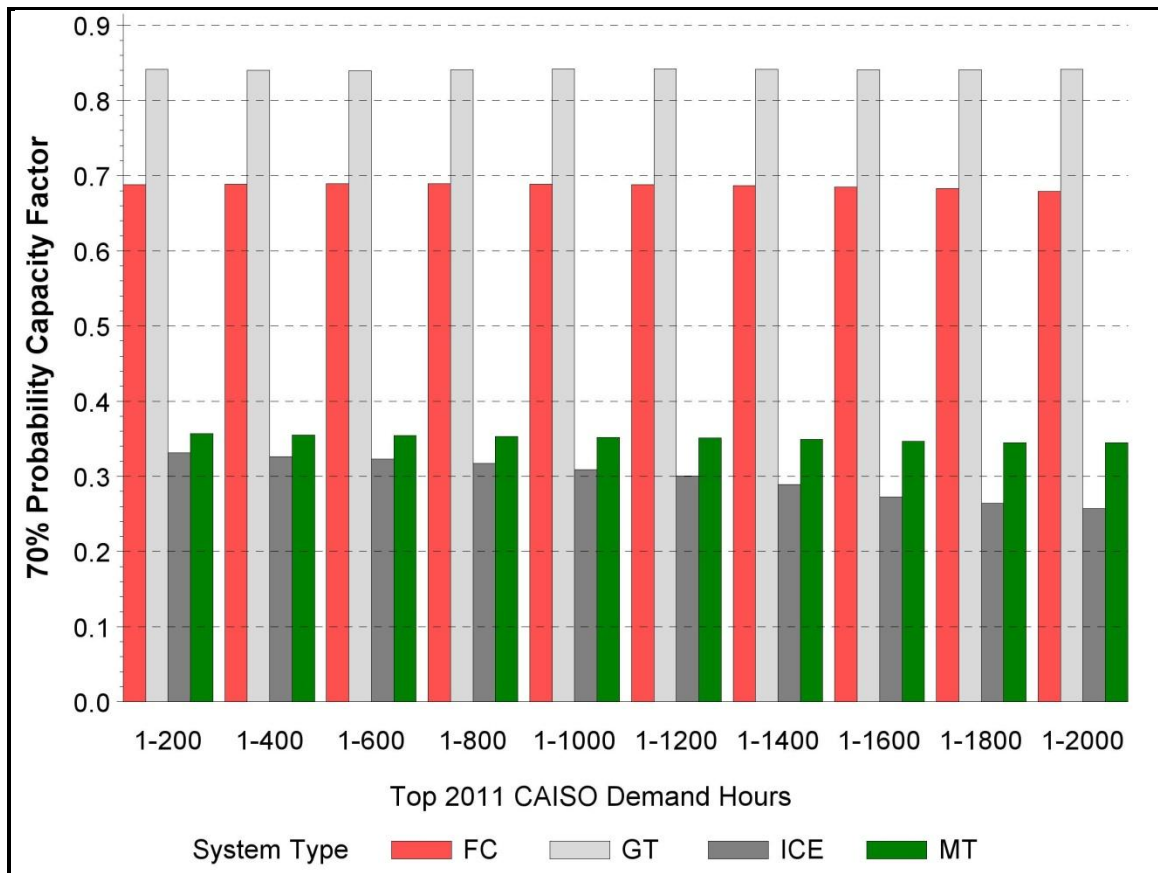
**Table 4-3: CAISO Annual Peak Hour Capacity Factor Trends**

Year	CAISO Peak Hour Capacity Factor				
	ICE	MT	FC	GT	Overall
2002	0.00	0.58	0.99		0.09
2003	0.58	0.58	1.02		0.59
2004	0.62	0.35	0.87	0.76	0.60
2005	0.64	0.46	0.67	0.73	0.62
2006	0.38	0.32	0.57	0.81	0.41
2007	0.38	0.45	0.76	0.83	0.44
2008	0.29	0.39	0.72	0.75	0.37
2009	0.35	0.38	0.67	0.85	0.43
2010	0.37	0.34	0.50	0.81	0.43
2011	0.34	0.35	0.70	0.83	0.44

Table 4-3 shows that ICE had CAISO peak hour capacity factors above 0.6 in 2004 and 2005. They fell markedly in 2006 and again in 2008. In 2010 they recovered to near their 2006 level. The 2011 value of 0.34 is well above the 2008 nadir but is almost half their historic high of 0.64. CAISO peak hour utilization for MT capacity did not follow the same trend as ICE capacity. In 2007 it outpaced ICE utilization but in the last three years the two have both had capacity factors near 0.35. GT and FC always have had higher CAISO peak hour capacity factors than ICE and MT. GT have remained above 0.7 in each year while FC have fallen no lower than 0.5. General differences in generation schedules between the two pairs of technologies explain some of the difference in CAISO peak hour utilization. But capacity mean age differences (that were shown in Figure 4-3), and increasing percentages of off-line capacity with age have exerted substantial downward pressure on utilization among program ICE and MT capacity.

It is important to look at demand reductions beyond those coincident with the single CAISO peak hour. Figure 4-17 shows program capacity factors by technology during the top 200, top 400, top 600, etc., hours through the top 2000 CAISO demand hours.

Figure 4-17: Program CAISO Top 2000 Peak Hour Capacity Factors



For each bin of hours in Figure 4-17 a program hourly capacity factor threshold is shown for the technology. These are the thresholds that were met during 70% of the bin's hours. For every bin, GT had threshold capacity factors above 0.8. FC had capacity factors just below 0.7 and dropping slowly as more hours were included in the bin. ICE and microturbines MT did not reach even 0.4 in any bin. As more hours were included the hourly capacity factor threshold for ICE then descended from above 0.3 to below 0.3. GT and FC thus delivered not only more demand impact but continued to do so over more non-coincident hours.

#### 4.4.2 Program Energy Impacts

Table 4-4 lists 2011 energy impacts by technology.

**Table 4-4: Program 2011 Energy Impacts by Technology**

Type	Fuel	Annual Energy	
		(GWh)	(%)
FC	N	68	9%
	R	110	14%
GT	N	187	25%
ICE	N	257	34%
	R	62	8%
MT	N	71	9%
	R	5	1%
<b>TOTAL</b>		<b>760</b>	<b>100%</b>

Total energy impacts for 2011 were 760 GWh; enough electricity to meet the needs of over 116,340 homes for one year.<sup>15</sup> ICE-N contributed the largest share with 257 GWh, 34% of the total. GT followed with 187 GWh. FC-R generated 110 GWh. None of the remaining technologies generated more than 10% of the total.

Table 4-5 breaks 2011 energy impacts out by calendar quarter. Quarterly energy supplied by the program is relatively equal by quarter, with summer impacts being only 30% higher than winter impacts.

<sup>15</sup> Assuming the typical home consumes approximately 6,670 kWh of electricity per year. From Brown, R.E. and Koomey, J.G. *Electricity Use in California: Past Trends and Present Usage Patterns*. Lawrence Berkeley National Laboratory. May 2002. <http://enduse.lbl.gov/info/LBNL-47992.pdf>. Value derived from Table 2 on page 8.

**Table 4-5: Program 2011 Quarterly Energy Impacts**

Technology	Fuel	Q1-2011 (GWh)	Q2-2011 (GWh)	Q3-2011 (GWh)	Q4-2011 (GWh)	Total* (GWh)
<b>FC</b>	N	14	17	19	18	68
	R	21	26	31	31	110
<b>GT</b>	N	44	47	47	50	187
	R	11	16	18	18	62
<b>ICE</b>	N	57	61	78	62	257
	R	14	19	18	20	71
<b>MT</b>	N	14	19	18	20	71
	R	1.2	0.9	1.4	1.4	5
<b>TOTAL</b>	N	128	143	162	150	583
	R	33	43	50	51	177
<b>TOTAL</b>		<b>161</b>	<b>186</b>	<b>211</b>	<b>201</b>	<b>760</b>

Table 4-6 shows program annual energy impact trends by technology from 2002 to 2011. Table 4-6 shows an estimated total electric energy impact of 4,537 GWh. The 2011 impacts of 760 GWh were 17% of that total. The 2011 impacts were 110 GWh greater than the 2010 estimated impact of 650 GWh. This 18% growth was largely driven by the 106 GWh increase from 71 to 177 GWh for FC between 2010 and 2011.

**Table 4-6: Program Annual Energy Impacts from 2002 to 2011**

Year	ICE (GWh)	MT (GWh)	FC (GWh)	GT (GWh)	Total (GWh)	Share (%)
2002	1	2	1	-	5	0
2003	151	17	2	-	169	4
2004	260	22	4	8	295	7
2005	324	36	12	30	402	9
2006	330	55	31	65	481	11
2007	319	73	55	92	538	12
2008	299	71	61	130	561	12
2009	339	78	70	189	677	15
2010	325	77	71	176	650	14
2011	319	76	177	187	760	17
<b>Total</b>	2,668	507	484	877	4,537	100
<b>Share (%)</b>	59	11	11	19	100	

The 2011 impacts from FC-R were substantially larger than any previous year. The increase was due almost entirely to the inclusion of directed biogas FC-R projects beginning in 2010 and the subsequent growth in 2011 in the number of directed biogas FC-R. FC-R prior to 2010 included

only FC that consumed on-site supplies of biogas. Directed biogas FC-R projects consume natural gas and do not face the same fuel supply issues confronting fuel cells powered by on-site biogas. This gives directed biogas FC-R an advantage over FC-R employing on-site biogas resources.

Figure 4-18 shows annual energy impacts for the different technologies over the course of the program. The upper row of bar charts shows the non-renewable technologies; the lower row, the renewable technologies.

**Figure 4-18: Program Annual Energy Contribution History**

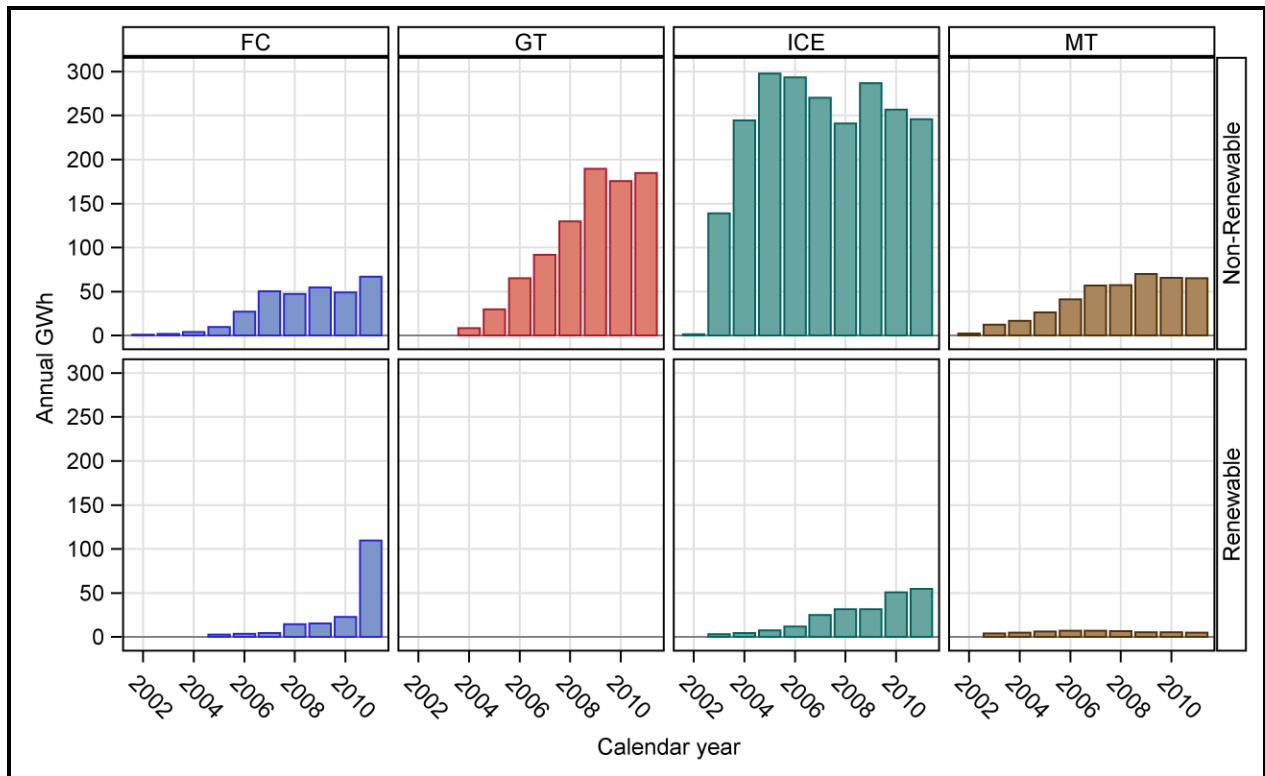


Figure 4-18 shows also that the large contributors in 2011, ICE-N and GT-N, have been the dominant contributors for most program years. The 2011 contribution of FC-R stands out. It is remarkable both for FC and also in terms of impact growth. The only similar instances of such dramatic growth in impacts were in 2002 and 2003 for ICE-N.

GT-N has held second place to ICE-N since 2006. The 2011 growth from FC-R puts it third place with a strong lead over other technologies. Additionally, Figure 4-18 shows that 2011 energy impacts were very similar to those of 2009 and 2010 for most technologies besides FC-R.

## 4.5 Program Administrator Impact Trends

Table 4-7 breaks down the 2011 energy impacts by individual Program Administrator.

**Table 4-7: Program Administrator 2011 Energy Impacts**

Type	Program Administrator								Annual Energy	
	PG&E		SCE		SCG		CCSE			
	(GWh)	(%)	(GWh)	(%)	(GWh)	(%)	(GWh)	(%)	(GWh)	(%)
<b>FC</b>	98	32%	27	31%	40	15%	12	11%	177	23%
<b>GT</b>	19	6%	.	.	92	35%	76	73%	187	25%
<b>ICE</b>	143	47%	51	58%	112	42%	13	13%	319	42%
<b>MT</b>	44	14%	10	11%	19	7%	3	3%	76	10%
<b>Total</b>	305	100%	87	100%	263	100%	104	100%	760	100%

Table 4-8 lists the 2011 capacity-weighted mean annual capacity factors by technology and Program Administrator.

**Table 4-8: Program Administrator Mean Annual Capacity Factors**

2011	Annual Capacity Factor			
	PG&E	SCE	SCG	CCSE
Technology	(kWyear/kWyear)			
<b>FC</b>	0.73	0.65	0.70	0.44
<b>GT</b>	0.55	0.00	0.83	0.95
<b>ICE</b>	0.26	0.19	0.24	0.14
<b>MT</b>	0.46	0.21	0.35	0.17

Table 4-8 shows substantial differences in 2011 mean annual capacity factors between the PAs. These differences include FC and ICE both having substantially lower capacity factors for CCSE than for the other PAs. The same is true for GT for PG&E when compared to SCE and SCG. Meanwhile, CCSE GT projects have the highest capacity factor. MT capacity factors have a wide range, with the lowest capacity factor again appearing for CCSE. However, there may be a number of reasons behind the differences; many of which are unknown and beyond the scope of an impact evaluation.

Table 4-9 lists the peak hour times and demands of the three investor-owned utilities (IOU) that serve program projects.

**Table 4-9: Investor-owned Utilities 2011 Peak Hour Demands**

IOU	Peak Demand (MW)	Date	Hour (PDT hour beginning)
PG&E	20,604	21-Jun-11	4 PM
SCE	22,107	7-Sep-11	3 PM
SDG&E	4,355	7-Sep-11	3 PM

SDG&E and SCE had peak hours on the same day but in the hour earlier than the CAISO peak. PG&E’s peak occurred several months earlier on June 21st.

Table 4-10 lists the demand impacts on the PG&E peak day from projects served electricity by PG&E.

**Table 4-10: PG&E Peak Hour Demand Impacts**

Technology	Count (n)	Capacity (MW)	Impact (MW)	Hourly Capacity Factor (kWh/kWh)
FC	43	13	9	0.70
GT	3	4	2	0.59
ICE	118	65	21	0.33
MT	58	11	5	0.46
	222	93	38	0.41

The peak hour demand impacts to PG&E totaled 38 MW. ICE delivered 21 MW from their 65 MW of capacity, with a corresponding their peak hour capacity factor of 0.33. FC delivered the second greatest demand impact with 9 MW. Their peak hour capacity factor was 0.70. MT were third with 5 MW and a capacity factor of 0.46. GT provided the smallest impact with just 2 MW but their capacity factor was on fairly high at 0.59.

Table 4-11 lists the demand impacts from projects served electricity by SCE. These projects include most SCE and some SCG projects.



**Table 4-11: SCE Peak Demand Impacts**

Technology	Count (n)	Capacity (MW)	Impact (MW)	Hourly Capacity Factor (kWh/kWh)
FC	24	7	5	0.64
GT	3	13	9	0.69
ICE	105	74	23	0.32
MT	56	10	2	0.24
<b>Total</b>	<b>188</b>	<b>104</b>	<b>39</b>	<b>0.38</b>

The peak hour demand impacts to SCE totaled 39 MW. As for PG&E, ICE delivered the greatest demand impact, with 23 MW from 74 MW of capacity. Their peak hour capacity factor also was like PG&E’s ICE, which were at 0.32. GT delivered the second greatest demand impact to SCE with 9 MW. Their peak hour capacity factor was 0.69. Fuel cells were third for SCE with 5 MW and a capacity factor of 0.64, very much like PG&E’s fuel cells. Microturbines had the fourth largest impact with 2 MW and a low capacity factor of just 0.24.

Table 4-12 lists the demand impacts from projects served electricity by SDG&E.

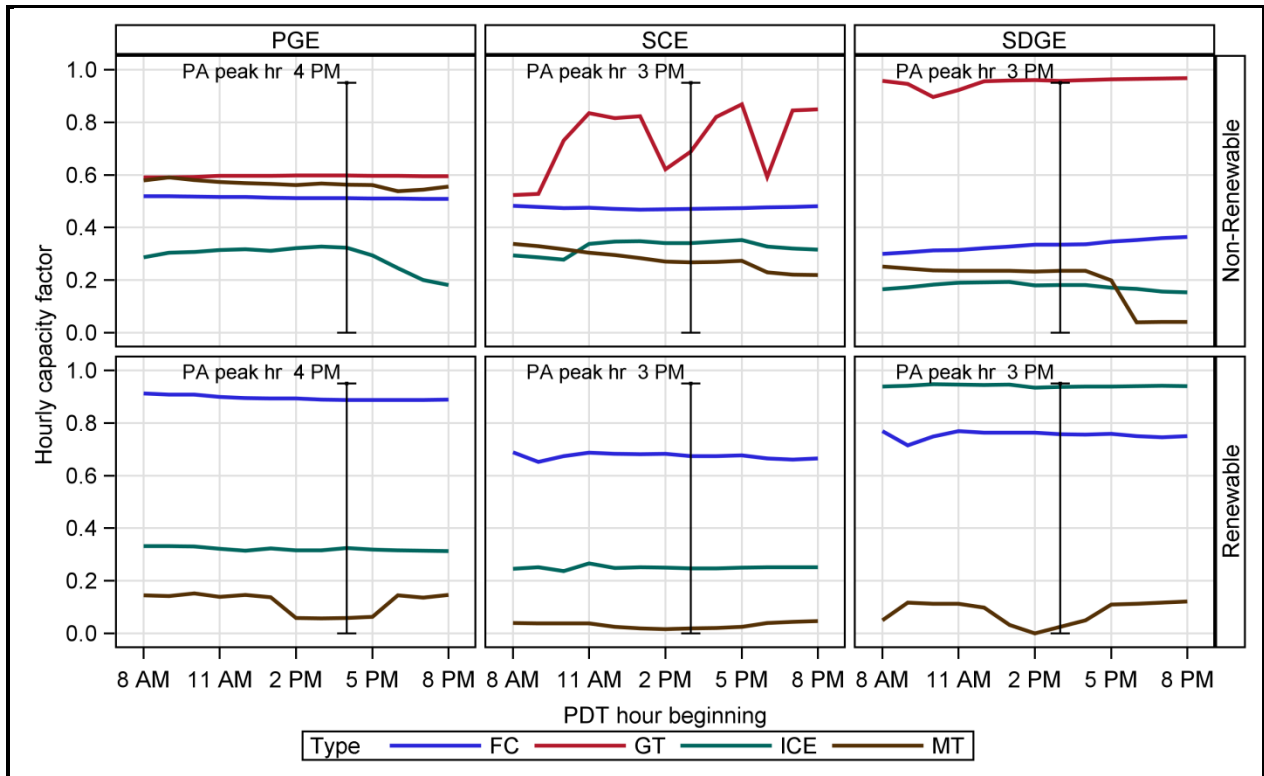
**Table 4-12: SDG&E Peak Demand Impacts**

Technology	Count (n)	Capacity (MW)	Impact (MW)	Hourly Capacity Factor (kWh/kWh)
FC	7	3	1.3	0.44
GT	2	9	9	0.96
ICE	22	13	3	0.21
MT	17	2	0.3	0.15
	48	27	13	0.49

The peak hour demand impacts to SDG&E totaled 13 MW. Unlike PG&E and SCE, ICE did not deliver the greatest demand impact. Instead, two GT delivered 9 MW with a very high capacity factor of 0.96. ICE followed with 3 MW but a low peak hour capacity factor of 0.21. As with SCE, FC were third for SDG&E with 1.3 MW and a somewhat low capacity factor of 0.44. Like PG&E and SCE, MT had the fourth largest impact with 0.3 MW and a very low capacity factor of 0.15.

Different fuel categories between like technology type did yield very different capacity factors for all three IOUs. Figure 4-19 shows the peak days for all three IOUs.

Figure 4-19: Investor-owned Utilities 2011 Peak Demand Days



## 4.6 Key Observations

The following key observations are made regarding observed technology utilization and impact trends from SGIP projects to date:

- Program annual energy and demand impacts continued to grow in 2011 as new program capacity continued to be added.
- Program annual energy and demand impacts have not always grown as new program capacity has been added.
- New directed biogas fuel cell capacity added greatly to 2011 energy and demand impacts due to its high utilization.
- Gas turbines have had highest annual and CAISO peak hour capacity utilizations since the technology first entered the program.
- For most program technologies, mean ages of capacity have been steadily increasing, contributing to increased percentages of retired capacity, declines in capacity utilization, and relative declines in their program impacts.
- Annual and CAISO peak hour utilizations of ICE-N program capacity have fallen with increasing mean capacity age, falling sharply at age 4

- Annual and CAISO peak hour utilizations of MT-N program capacity have fallen with increasing mean capacity age. They fell more gradually than ICE-N and sharply beyond age 8.
- Mean ages of FC-N and FC-R program capacities are younger than other technologies.
- As older projects retire they no longer contribute energy or demand impacts, thus reducing program annual and CAISO peak hour capacity factors.

# 5

## Efficiency and Waste Heat Utilization

---

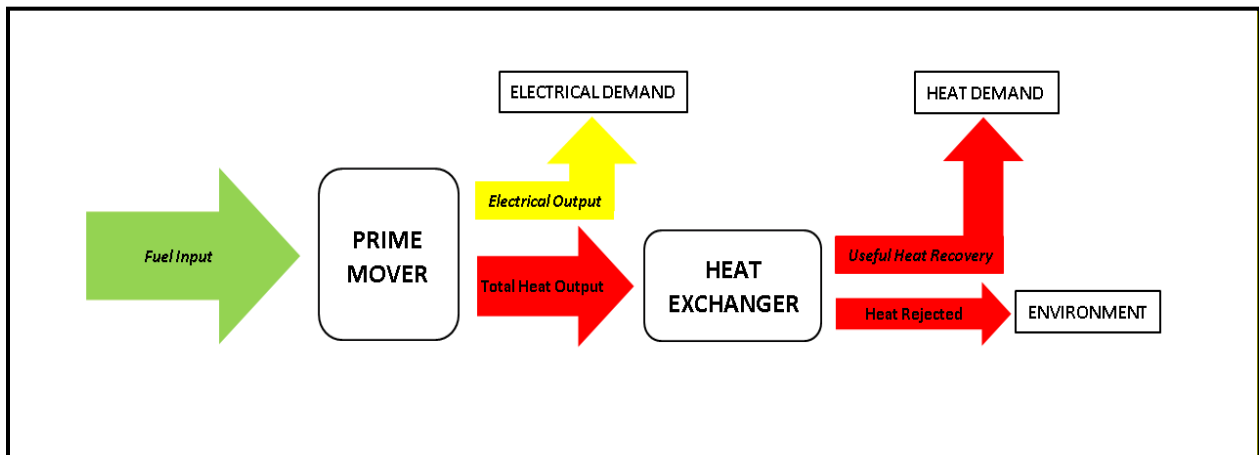
### 5.1 Introduction

Useful waste heat recovery is an important factor in the overall project performance of combined heat and power (CHP) projects. This waste heat recovery is critical both to customer return-on-investment and meeting program goals like greenhouse gas reductions. Section 4 summarized the electrical impacts of projects installed under the SGIP. In this section, we summarize the fuel consumed by those projects and their useful recovered heat.

#### 5.1.1 Terms and Definitions

Figure 5-1 is a project level energy flow schematic for a typical SGIP project with waste heat recovery. Energy flows in italics represent a metered input or output.

**Figure 5-1: Energy Flow Schematic**



Starting from the left, renewable or non-renewable fuel enters the prime mover (fuel cell, gas turbine, etc.). Any project will convert some of the fuel input energy into electrical output and the rest of the energy in the fuel will be dissipated as heat. A project's ability to convert fuel into electrical output is its Electrical Conversion Efficiency (ECE).

Mathematically, the ECE can be defined as follows:

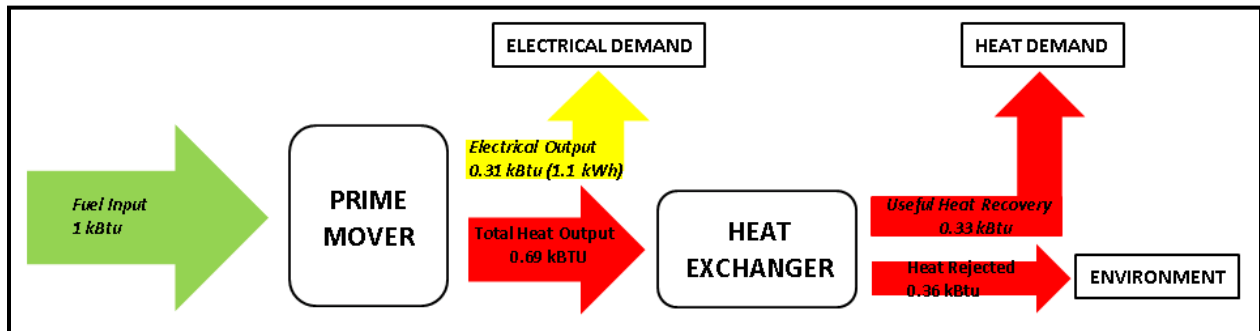
$$ECE = \frac{\text{Electrical Output}}{\text{Fuel Input (LHV)}}^1$$

The rest of the fuel energy that is not converted into electricity is dissipated as heat, some of which goes out in the exhaust. Equipment manufacturers typically list this exhausted heat output as available waste heat in specification sheets. However, this exhausted heat output (or waste heat) may not be the same amount of heat that is actually recovered and used in SGIP projects. A heat exchanger or water jacket is often used to capture some of the waste heat and transport it to the required end use (e.g., a space heater or an absorption chiller). The heat captured by the heat exchanger is defined as the useful recovered heat.<sup>2</sup> This recovered heat directly offsets gas that would have been burned in a boiler. Note that unless the CHP project developer closely matches the thermal output from the CHP project to the thermal demand at the customer facility, there is likelihood that more heat will be generated than can be used at the site. We define a project’s ability to generate and capture this useful heat as its useful heat conversion efficiency.

$$\text{Useful Heat Conversion Efficiency} = \frac{\text{Useful Heat Recovered}}{\text{Fuel Input (LHV)}}$$

For illustrative purposes, consider a natural gas-fueled IC engine with an ECE of 31% and a useful heat conversion efficiency of 33% (typical values observed in 2011) is used at a facility to help meet on-site electrical and heat demands. The flow of energy for this hypothetical project is presented graphically in Figure 5-2.

**Figure 5-2: Energy Flow Schematic for Hypothetical IC Engine**



<sup>1</sup> HHV natural gas values assumed at 1020 BTU/Ft<sup>3</sup>. Use of HHV values assume the water vapor heat of vaporization is extracted through a condensing process. LHV natural gas values are assumed at 920 BTU/Ft<sup>3</sup>. The majority of this analysis uses LHV as most of the CHP projects are unlikely to fully condense out the water vapor and recover the heat of vaporization. However, HHV values are used for examining compliance with AB 1685 requirements.

<sup>2</sup> Where possible, the useful recovered heat is determined by metering equipment. Usually, inlet and exit temperatures and flow rates are measured in order to calculate the useful recovered heat.

For every 1,000 Btu (i.e., 1 kBtu) of fuel input, this representative IC engine would produce 0.31 kBtu (equivalent to 1.1 kWh) of electrical energy given its 31% ECE. The rest of the energy of the input fuel, 0.69 kBtu in this case, leaves the IC engine in the form of heat. At this point, the demand for heat at the facility dictates the percentage of heat energy that will be recovered as *useful* heat. For a project with a 33% useful heat conversion efficiency, one-third of the input fuel energy is captured and used at the facility. This means for each 1,000 Btu of fuel input, approximately 330 Btu will be recovered and used at the facility. Altogether, 64% of the input energy is recovered as electrical and heat energy. This leaves only 36% of the energy lost as heat rejected to the environment. In contrast, projects that do not capture and use the waste heat lose over 2/3rds of the energy contained in the fuel.

CHP projects represent the vast majority of the on-line generating capacity of the SGIP.<sup>3</sup> To help ensure that CHP projects in the SGIP harness waste heat effectively and realize high overall project efficiencies, Public Utility Code (PUC) 216.6 requires that qualified<sup>4</sup> CHP projects meet minimum levels of annual thermal energy utilization and overall project efficiency.

PUC 216.6(a) requires that recovered useful waste heat from a CHP project exceed 5% of the combined recovered waste heat plus the electrical energy output of the project. PUC 216.6(b) requires that the sum of the electric generation and half of the heat recovery of the project exceed 42.5% of the energy entering the project as fuel. Table 5-1 summarizes these requirements.

As applied, the PUC requirements are primarily geared to ensuring appropriate design of CHP projects rather than on ensuring project compliance over time. In particular, the requirements are only checked during the incentive application process. The values are not verified after the project is operational and there are no direct penalties for failing to meet the requirements. Note also that projects using renewable fuel and projects that exceed an electric efficiency of over 40% (on a high heating value basis) are exempt from PUC 216.6 requirements.

---

<sup>3</sup> Non-CHP sources of generating capacity within the SGIP include electric-only fuel cells and most of the projects using renewable-fuels, including wind.

<sup>4</sup> “Qualified” means CHP projects using non-renewable-fueled fuel cells, IC engines, gas turbines, and microturbines.

**Table 5-1: Required Minimum PUC 216.6 Levels of Performance**

Element	Definition	Minimum Requirement (%)
216.6(a)	Proportion of project’s total annual energy output in the form of useful heat	5.0
216.6(b)	Sum of electrical efficiency and half of useful heat conversion efficiency, LHV	42.5
AB1685	Sum of electrical efficiency and ALL of useful heat conversion efficiency, HHV	60.0
Project Efficiency	Sum of electrical efficiency and useful heat conversion efficiency, LHV	N/A

Table 5-2 shows the estimated amount of fuel consumed and useful heat recovered across the entire set of SGIP projects during 2011. The amount of useful heat recovered is nearly 20% of the fuel consumed by the projects. This percentage is slightly lower than previous years because of the increasing presence of projects that are not required to recover heat—especially electric only and renewable fuel cells. On an energy basis, useful recovered heat added 52% to the electrical energy supplied to the SGIP in 2011 for all projects.<sup>5</sup>

**Table 5-2: Program Level Heat and Fuel Impacts**

Technology Type	Estimated Useful Heat Recovered (Billion Btu)	Estimated Fuel Consumed (Billion Btu) <sub>LHV</sub>	Useful Heat Energy as Percentage of Electrical Energy
FC	43	1,035	7%
GT	346	2,006	54%
ICE	776	2,834	71%
MT	192	1,066	74%
<b>Total</b>	<b>1,358</b>	<b>6,942</b>	<b>52%</b>

SGIP projects use a variety of means to recover heat and use that heat to meet on-site heating and cooling needs of customers. Table 5-3 summarizes the end uses served by recovered useful thermal energy. This table only includes SGIP projects subject to heat recovery requirements in 2011.

<sup>5</sup> This includes projects that use both renewable and non-renewable fuels. Projects that use non-renewable fuels added 66% in the form of useful heat to the electrical energy that they produced. Projects that use renewable fuels added only 6% in the form of useful heat.

**Table 5-3: End-uses Served by Recovered Useful Thermal Energy**

End Use Application	Completed Projects (n)	Completed Capacity (kW)
Cooling Only	39	33,811
Heating & Cooling	83	62,960
Heating Only	309	104,654
To Be Determined	2	360
<b>Total</b>	<b>433</b>	<b>201,785</b>

Within the SGIP, the recovered heat is predominantly used to help offset on-site heating needs. However, nearly 30% of the projects by count and 50% of the projects by capacity use the recovered heat to help address on-site cooling needs. The higher fraction on a capacity basis suggests that larger projects are more likely to be coupled to heat driven chillers (i.e., absorption or adsorption chillers) than smaller projects.

## 5.2 PUC 216.6 Compliance

In assessing compliance of the SGIP with PUC 216.6 requirements, we look at program-wide results as well as results at the project level. Program-wide PUC 216.6 performance results are calculated as capacity weighted averages.<sup>6</sup> Table 5-4 provides results on PUC 216.6 (a) and (b) requirements for each technology type using capacity weighted averages.

**Table 5-4: PUC 216.6 CHP Project Performances by Technology**

Technology	Number of Projects (n)	216.6(a) Proportion as Useful Heat (%)	216.6(b)* Avg. Efficiency Level Achieved (% LHV) <sup>7</sup>
FC	72	20.6%	48.6%
GT	8	35.1%	40.5%
ICE	231	45.8%	44.0%
MT	122	44.0%	32.0%

\* All 216.6(b) results in this table are better than 10% precision at the 90% confidence level.

PUC 216.6(a) results are expressed within the third column of Table 5-4 as the proportion of the total output energy recovered as useful heat for each qualified CHP technology. For example, fuel cells in the SGIP recovered on average more than 20% of their total output energy as useful heat, whereas IC engines recovered on average nearly 46%. All of the CHP technologies in the SGIP achieved and exceeded the PUC 216.6(a) requirement of providing at least 5% of the output energy as useful heat.

<sup>6</sup> Results at the program level are based on performance data for metered projects and estimated performance data for unmetered projects.

<sup>7</sup> PUC 216.6(b) is defined as electrical energy plus half of thermal energy divided by fuel consumption (LHV).



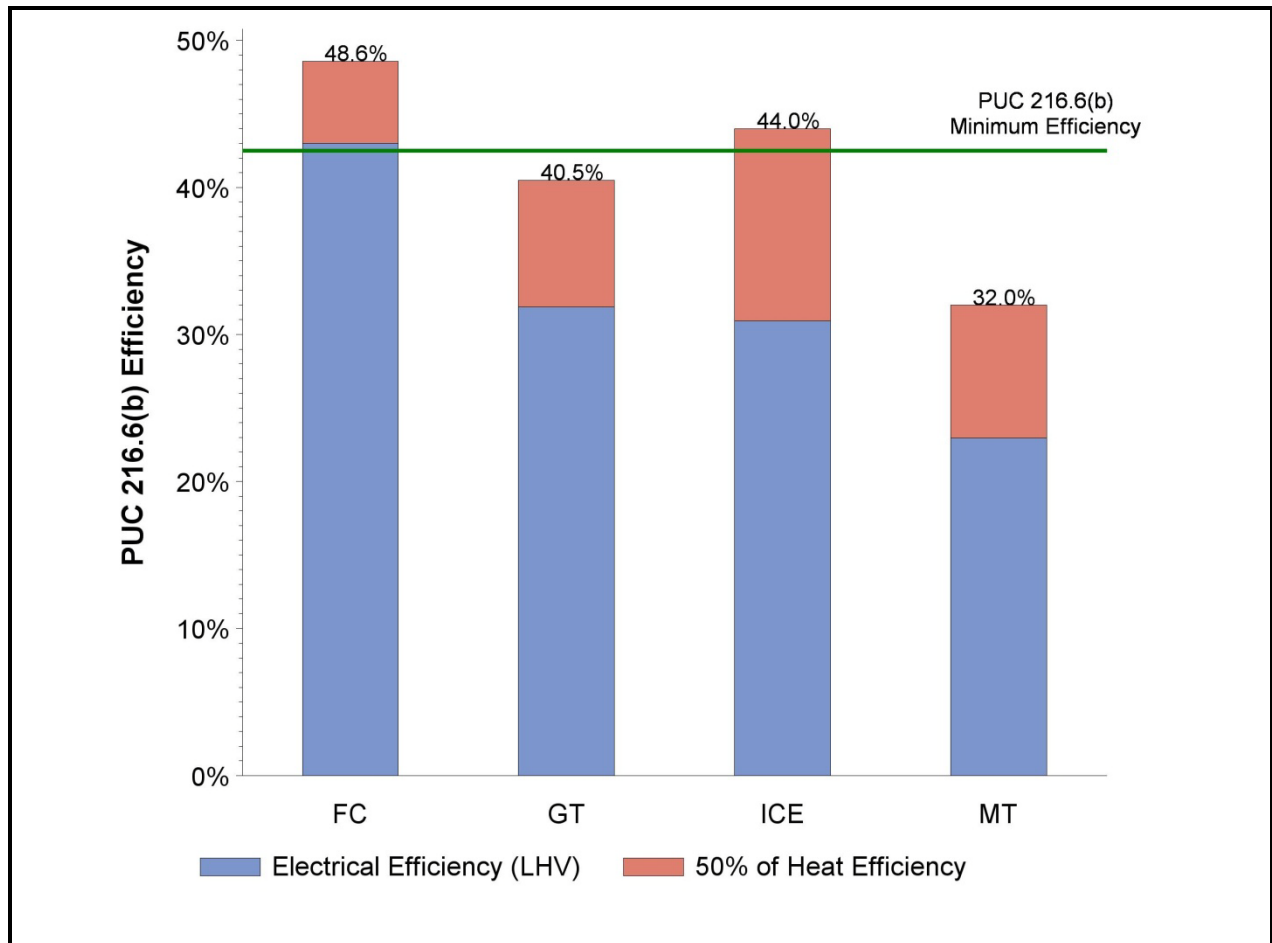
PUC 216.6(b) results in Table 5-4 are expressed in the last column as the average overall PUC 216.6(b) efficiency achieved by the technology. Fuel cells as a whole exceeded the required 42.5% threshold with a weighted average PUC 216.6(b) project efficiency of over 48% as did IC engines with a weighted average of 44%. Factors influencing this outcome include the high electric conversion efficiency of fuel cells and the high degree of waste heat utilization for IC engines during 2011. Gas turbines narrowly missed the 42.5% threshold in 2011 with a weighted average PUC 216.6(b) efficiency of 40.5%. The microturbine 216.6(b) results in 2011 fell substantially short of the 42.5% threshold. The shortfall is due in part to a difference in electrical conversion efficiency, which was lower for microturbines than for any of the other prime mover technologies and is consistent with previous years.

Figure 5-3 is a graphical depiction of the PUC 216.6(b) results. The results may be thought of as representing the weighted average performance of all of the projects as a single, very large project of each technology type. This basis is intended to yield results that can be compared directly with other pertinent reference points (e.g., performance of large, centralized power plants). Note that projects exempt from PUC 216.6 requirements are excluded from both the table and figure.<sup>8</sup>

---

<sup>8</sup> It is interesting to note that projects exempted from heat recovery on the basis that they exceed the 40%<sub>(HHV)</sub> electrical conversion efficiency requirement would actually meet PUC 216.6(b). In particular, these projects achieve the requirements because 40%<sub>(HHV)</sub> is equivalent to approximately a 44%<sub>(LHV)</sub> electrical conversion efficiency, which is above the 42.5% minimum.

**Figure 5-3: PUC 216.6(b) Compliance**

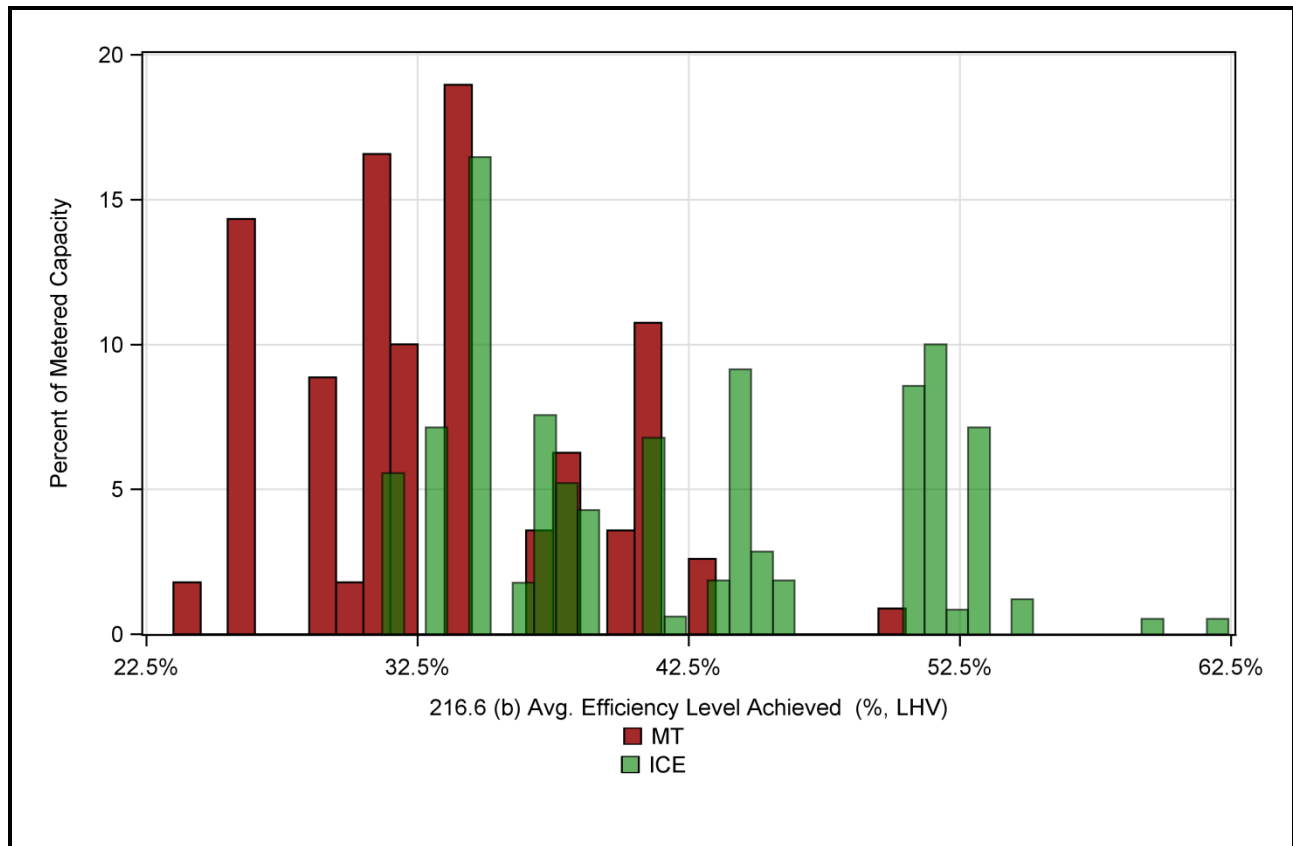


The CHP program-wide performance results in Table 5-4 reflect weighted average performance for the entire population of projects within a technology group. The results use a combination of metered electric output, metered fuel input, and metered heat recovery data to estimate the weighted average performance. Consequently, while the weighted average results portray a single value by technology, this masks the distribution of results associated with the individual projects.

Examining PUC compliance at the project specific level shows the high amount of variability exhibited by the population of projects. Figure 5-4 shows this variation in performance for microturbines and IC engines.<sup>9</sup>

<sup>9</sup> The results are limited to projects that had a requisite amount of metered electricity, heat, and fuel data.

**Figure 5-4: Metered Microturbine and IC Engine PUC 216.6(b) Project Efficiencies**



The red columns in Figure 5-4 represent PUC 216.6(b) results for individual microturbine projects and the green columns represent individual IC engine project results. As expected from the low average weighted results shown in Table 5-4, a large number of the microturbine projects fail to meet PUC 216.6(b) requirements. However, a small number of microturbine projects did, in fact, meet PUC 216.6(b) requirements. Conversely, although IC engines meet PUC 216.6(b) in aggregate, a number of the individual projects failed to meet the PUC 216.6(b) requirement. As more and more individual projects fail to achieve PUC 216.6(b), there is a greater likelihood that the technology class will fail at the program-wide level. This is important because PUC 216.6(b) is an indicator of a CHP project’s ability to achieve GHG emission reductions.

Low electrical generation efficiency is a primary reason why most SGIP microturbines fail to meet PUC 216.6(b) requirements. Table 5-5 shows electrical conversion efficiencies for SGIP projects by technology. This table shows that the electric conversion efficiency of microturbines averaged 23%. Due to their relatively low electrical efficiencies, microturbines would require commensurately higher heat recovery ratios than other technologies in order to meet the 216.6(b) requirements.

**Table 5-5: Electric Conversion Efficiencies—Metered Projects<sup>10</sup>**

Technology	Number of Metered Projects (n)	Mean Electrical Conversion Efficiency (%LHV)
FC	94	45.9%
GT	6	31.9%
ICE	102	30.9%
MT	50	23.0%

Another reason microturbines failed to meet PUC 216.6(b) requirements is the lack of sufficient thermal load occurring at the same time the SGIP project is generating electricity and producing waste heat. In other words, many facilities do not have a need for the waste heat provided by the generator or the SGIP project design failed to match the timing and magnitude of thermal load and electrical output. As a result, the project may generate waste heat during operation that is then ‘dumped’ because the customer has no need or only has a partial need for the heat. PUC 216.6(b) credits only *recovered heat used by the project* in the efficiency calculation. Waste heat generated by the SGIP project not used by the project fails to get credit. As a result, lack of thermal load reduces the project’s ability to achieve the overall required level of efficiency. For microturbines, with already low electrical efficiencies, the lack of waste heat recovery credit severely reduces their ability to achieve PUC 216.6(b) requirements. In contrast, technologies with relatively high electrical conversion efficiencies (such as fuel cells), a relatively low thermal load or heat recovery rate has less impact on the project’s ability to meet the PUC 216.6(b) requirement. The impacts of high electrical efficiency and waste heat recovery on ability to meet the PUC 216.6(b) requirement are amply illustrated in Figure 5-3.



CHP engines need cooling when they are generating electricity. Recovering this waste heat is similar to the heater in a car. ‘Insufficient thermal load’ is analogous to when it is too warm to run the heater so the rest of the heat produced by the engine has to be rejected through a radiator or other means. Otherwise, the engine will overheat, just like a car with a broken radiator

Table 5-6 summarizes actual heat recovery rates observed for metered projects by technology type. These rates are drawn only from projects where at least 30 days of both metered heat and electrical performance data were available. The left portion of the table summarizes heat recovery rates measured for individual projects. For example, heat recovery rate was measured for only three fuel cell projects. The mean of the three site-specific heat recovery rates was relatively low at 0.87 kBtu of heat recovered per kWh of generated electricity (kBtu/kWh). The

<sup>10</sup> Data is presented only for projects with metered electrical and fuel data.

second column from right of Table 5-6 contains capacity-weighted average heat recovery rates for each of the prime mover technologies. These capacity-weighted average heat recovery rates were used to estimate heat recovery in cases where useful heat recovery was not metered. For reference, the rightmost column shows an example heat recovery rate drawn from a manufacturer’s specifications. These specification values are higher than the mean values but nearly equal to or less than the observed maximum values.

**Table 5-6: Details of Heat Rate Recovery by Technology**

Technology Type	n	Min	Max	Median	Mean	Std Dev	Capacity Weighted Average	Reference Example
FC	3	0.12	2.30	0.19	0.87	1.24	<b>0.40</b>	<b>2.40</b>
GT	4	0.33	3.70	1.99	2.00	1.68	<b>1.93</b>	
ICE	23	0.15	6.86	2.83	2.73	2.00	<b>2.34</b>	<b>4.26</b>
MT	24	0.53	8.18	2.69	3.07	1.92	<b>2.86</b>	<b>6.75</b>

### 5.3 AB 1685 (60%) Efficiency Status

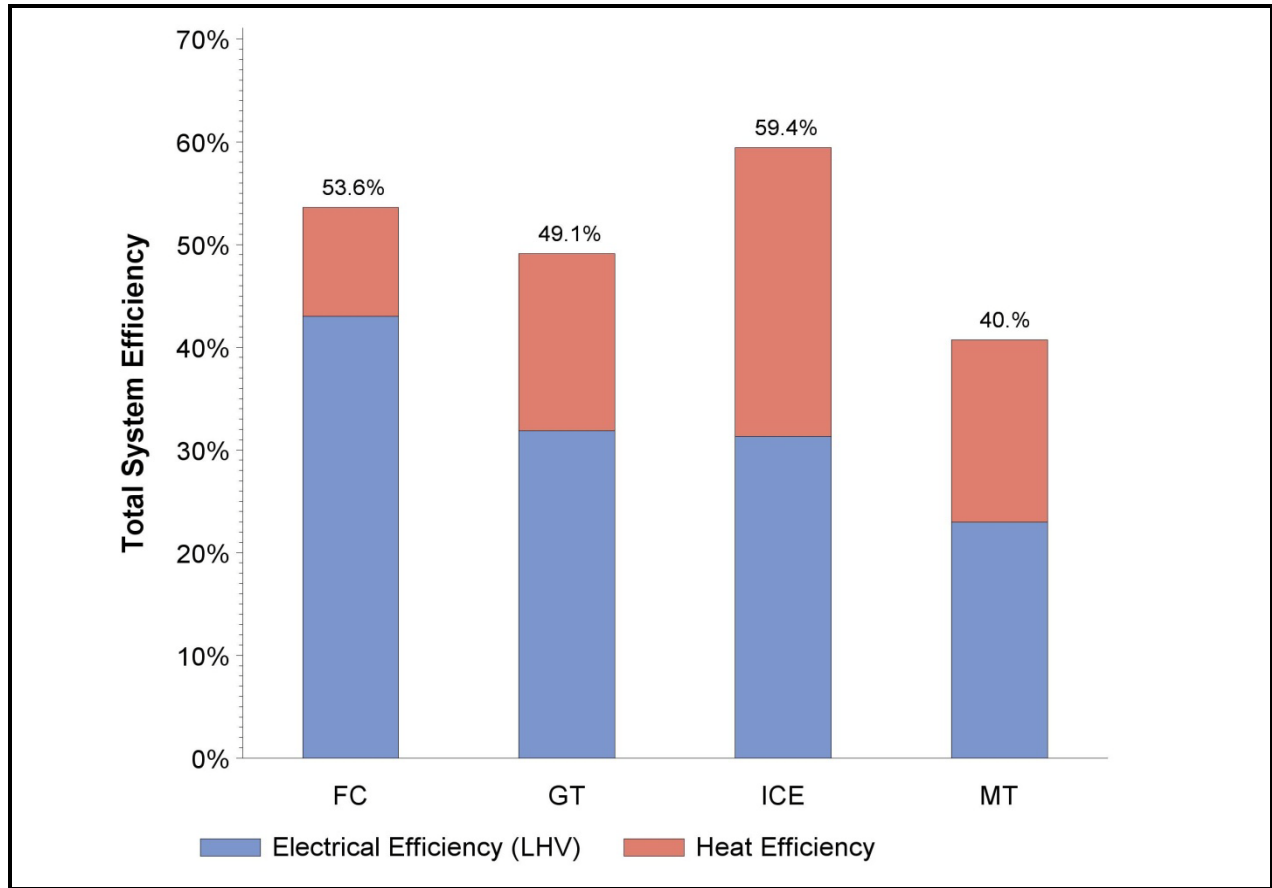
Assembly Bill 1685 (Leno, October 12, 2003) required that all SGIP combustion-based technologies operating in a CHP application achieve a 60% project efficiency on a higher heating basis. We calculated overall technology efficiencies for each non-renewable-fueled CHP technology on-line in 2011. Table 5-7 provides technology-specific summary statistics for overall project efficiency. All technologies failed to meet the 60% requirement at the population level.

**Table 5-7: CHP Project Overall Project Efficiency by Technology**

Technology	Number of Projects (n)	Overall Project Efficiency (% HHV)
FC	72	48.9%
GT	8	44.3%
ICE	231	51.5%
MT	122	37.0%

Figure 5-5 shows total project efficiency (on a LHV basis) for projects required to recover heat. Also shown is the contribution of electrical and thermal energy. Overall technology efficiencies ranged from 40% to 59% in 2011. IC engines had the best overall efficiency but were slightly lower than 2010, potentially due to the IC engine fleet aging relative to other technologies. Fuel cells had the next highest project efficiencies, driven largely by high electrical fuel conversion efficiencies.

**Figure 5-5: Total Project Efficiency, LHV**



### 5.4 California Air Resources Board (CARB) NO<sub>x</sub> Compliance

Beginning in 2005, non-renewable-fueled engine and turbine projects applying to the SGIP were required to meet a 2005 CARB NO<sub>x</sub> emission requirement. The CARB standard required these projects to emit not more than 0.14 pounds of NO<sub>x</sub> per Megawatt-hour of generated electricity (lbs/MWh). The CARB NO<sub>x</sub> standard could be met by using a fossil fuel combustion emission credit for waste heat utilization so long as the project achieved the 60 percent minimum efficiency standard.

The following formula was used to determine project efficiency:

$$SystemEfficiency = \frac{(E + T)}{F}$$

Where E is the generating project’s rated electric capacity converted into equivalent Btu per hour, T is the generating project’s waste heat recovery rate (Btu per hour) at rated capacity, and

F is the generating project's higher heating value (HHV) fuel consumption rate (Btu per hour) at rated capacity.

The waste heat utilization credit was calculated by the following equation:

$$MW_{WH} = \frac{\text{UtilizedWasteHeat} \left( \frac{1}{3.4} \right)}{EFLH}$$

Where UtilizedWasteHeat is the annual utilized waste heat in MMBtu per year, 3.4 is the conversion factor from MWh to MMBtu, and EFLH is the project's annual equivalent full load hours of operation.

The following equation was used to determine if the project meets the NO<sub>x</sub> requirement:

$$NO_x = \frac{NO_x \text{ emissionrate}}{MW_r + MW_{WH}}$$

Where NO<sub>x</sub>emissionrate is the project's verified emissions in pounds per MWh without thermal credit, MW<sub>r</sub> is the project's rated capacity in MW, and MW<sub>WH</sub> is the waste heat utilization credit in MW. The result represents a NO<sub>x</sub> emission rate (lbs per MWh) which utilizes the thermal credit. If this rate was less than 0.14 lbs per MWh, then the project qualified.

Effective January 1, 2007, CHP projects receiving incentives under the SGIP were required to meet a CARB NO<sub>x</sub> emission limit of 0.07 lbs/MWh.<sup>11</sup> Fuel cells and microturbines have been promoted as having low NO<sub>x</sub> emissions without the use of post combustion controls. In contrast, most IC engines must employ post-combustion NO<sub>x</sub> controls to meet the CARB NO<sub>x</sub> emission requirement.

CARB maintains a list of DG equipment that has achieved the NO<sub>x</sub> emission requirements.<sup>12</sup> In general, most fuel cell technologies applying after 2009 to the SGIP meet the CARB 2007 NO<sub>x</sub> certification requirements. Among microturbines, only two equipment manufacturers have met the CARB 2007 NO<sub>x</sub> certification requirements. No IC engine technology has yet achieved the CARB 2007 NO<sub>x</sub> certification requirements.

In order to understand the CHP technologies that may be affected by the 2007 CARB NO<sub>x</sub> standard and use the 60% efficiency approach, we can examine the number of CHP projects in

---

<sup>11</sup> The CARB DG NO<sub>x</sub> rules were implemented in accordance with Senate Bill 1298 (chaptered September 2000).

<sup>12</sup> The list is located at: <http://www.arb.ca.gov/energy/dg/eo/eo-current.htm>

the SGIP following adoption of the standard. Table 5-8 shows the delineation between projects installed before and after the implementation of the 2007 CARB NO<sub>x</sub> rules.

**Table 5-8: Completed Projects by CARB NO<sub>x</sub> Standards**

<b>Project Type</b>	<b>Completed Projects (n) Before 2007 CARB NO<sub>x</sub> Standards</b>	<b>Completed Projects (n) Under 2007 CARB NO<sub>x</sub> Standards</b>
FC	14	65
GT	8	0
ICE	215	15
MT	114	5
<b>Total</b>	<b>351</b>	<b>85</b>

Although there are 65 fuel cell projects that are potentially affected by the 2007 CARB NO<sub>x</sub> standard, essentially all represent CARB certified equipment. As a result, fuel cells will most likely not have to use the 60% system efficiency approach to achieve compliance.

Of the five microturbines that are subject to the CARB standard, at least three represent CARB certified equipment. These microturbine projects will not have to meet the 60% system efficiency approach to achieve compliance. However, the other two microturbine projects will have to use the 60% system efficiency approach to achieve compliance; in light of the system efficiency results shown in Table 5-7, their capability to achieve compliance appears to be remote.

As no IC engines meet CARB certification, all of the 15 IC engines subject to the CARB NO<sub>x</sub> standard will have to use the 60% system efficiency approach to achieve compliance. Based on the results shown in Table 5-7, CHP projects employing IC engines will achieve the CARB NO<sub>x</sub> standard only through very high waste heat utilization.

## **5.5 Fuel and Heat Trends**

CHP projects receiving incentives under the SGIP produce both electrical and thermal energy by burning natural gas or biogas. Investigating the electrical and thermal energy output of different CHP technologies over time can yield insights into performance aspects of the technologies and the affects of fuel type.



Figure 5-6 shows the annual electrical and thermal energy produced by technology type from 2002 through 2011. There was a notable upswing in fuel cell electrical energy in 2011 but there was no corresponding upswing in thermal energy delivered by these projects. This lack of thermal energy recovery is likely due to the exemption of electrical-only fuel cells and renewable-fueled projects (largely directed biogas projects) from heat recovery requirements. Microturbines and gas turbines recovered more heat as a percentage of electrical output. However, as shown previously in Table 5-4 and Table 5-5, the low electrical conversion efficiencies of these projects makes meeting overall technology efficiency targets challenging.

**Figure 5-6: Electrical and Thermal Energy by Year and Technology**

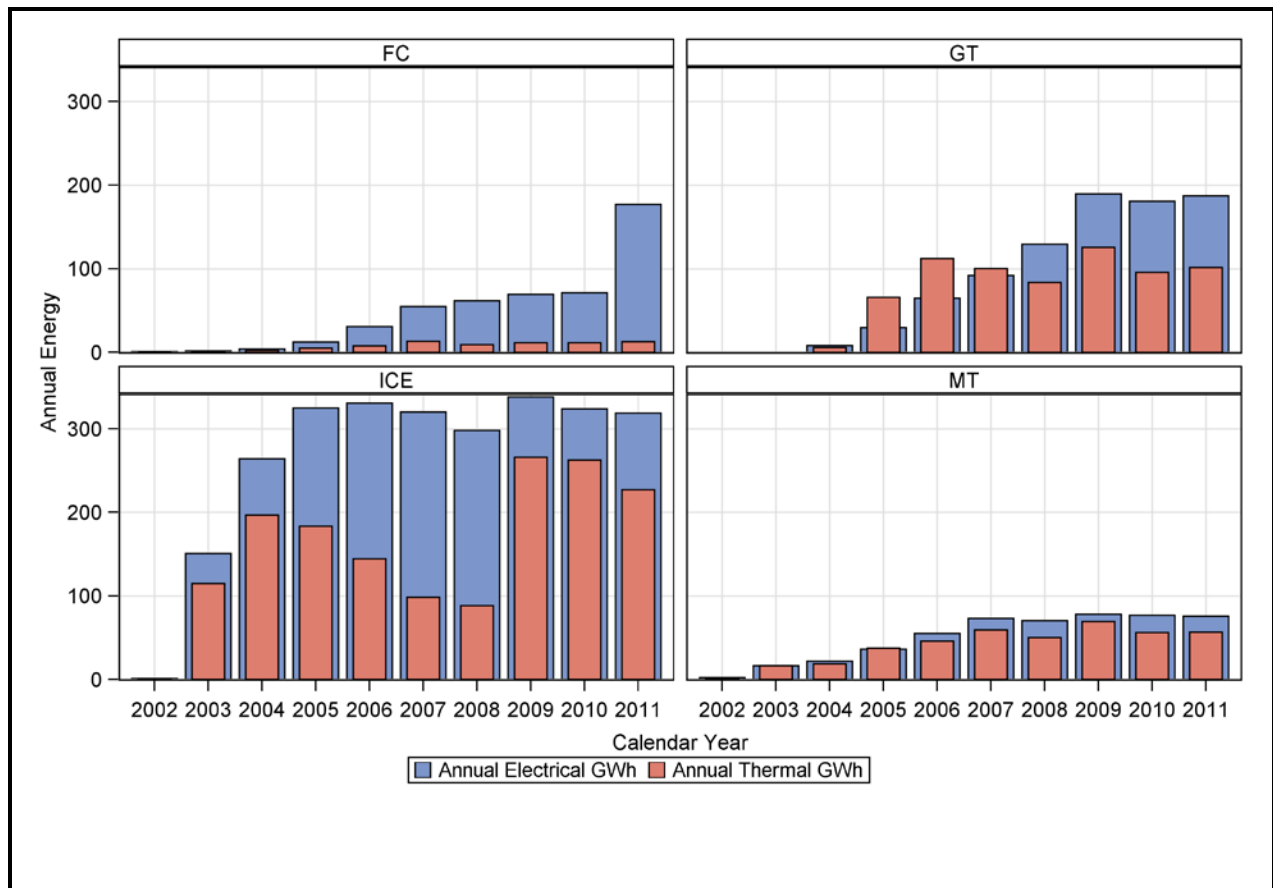
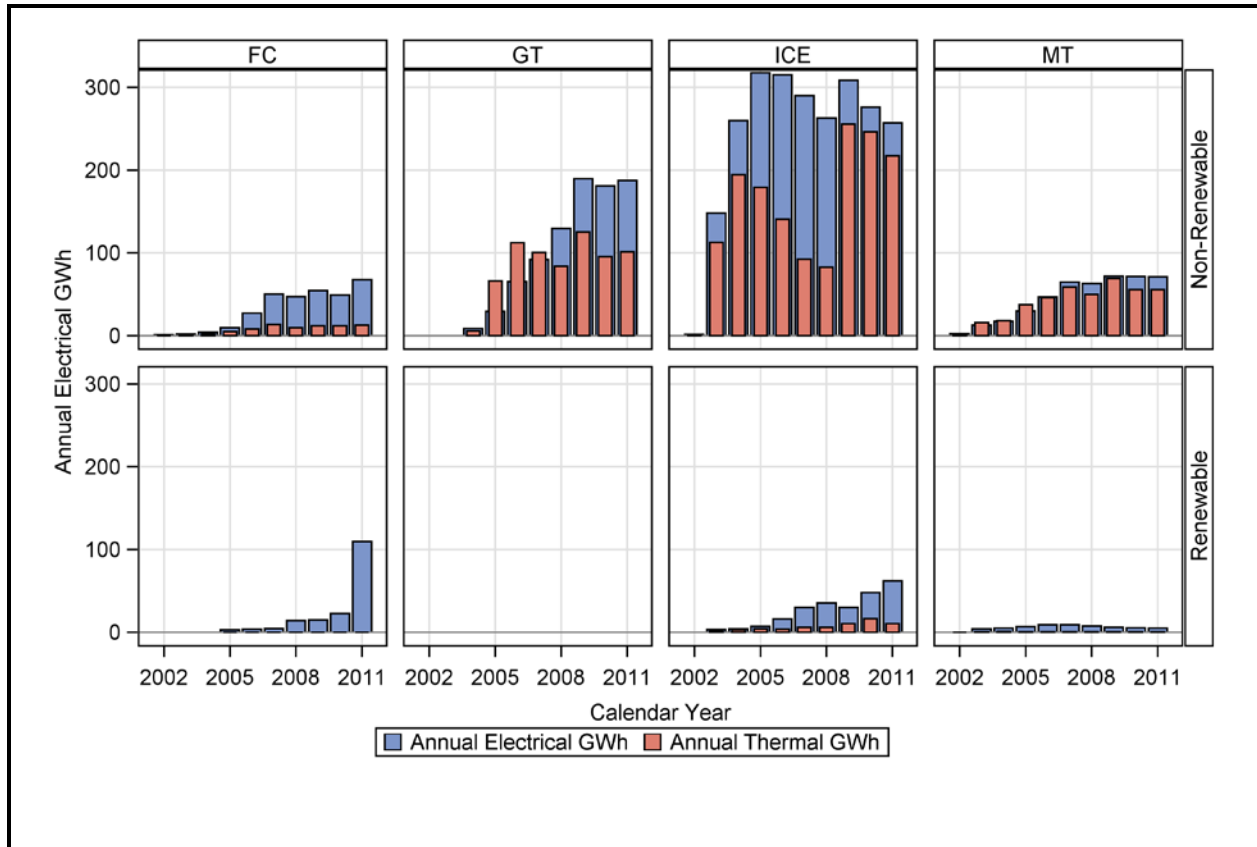


Figure 5-7 provides a further breakdown in energy production trends between projects that are fueled from non-renewable natural gas and those fueled by renewable sources like biogas.

**Figure 5-7: Electrical and Thermal Energy by Year, Technology, and Fuel**



Two important observations are evident from Figure 5-7:

- The large increase in fuel cell electrical energy is driven primarily by renewable-fuel projects. Because these projects do not recover heat, there is no corresponding increase in thermal energy. The lack of heat recovery is likely due to lack of program requirements to recover heat, largely driven by exemptions resulting from the use of renewable fuels (on site or directed).
- A few IC engines use renewable-fuel and recover heat even in the absence of program requirements to do so.

We further investigate the differences between energy production or fuel cells and IC engines in Figure 5-8 and Figure 5-9, respectively.

**Figure 5-8: Electrical and Thermal Energy by Year for Fuel Cells**

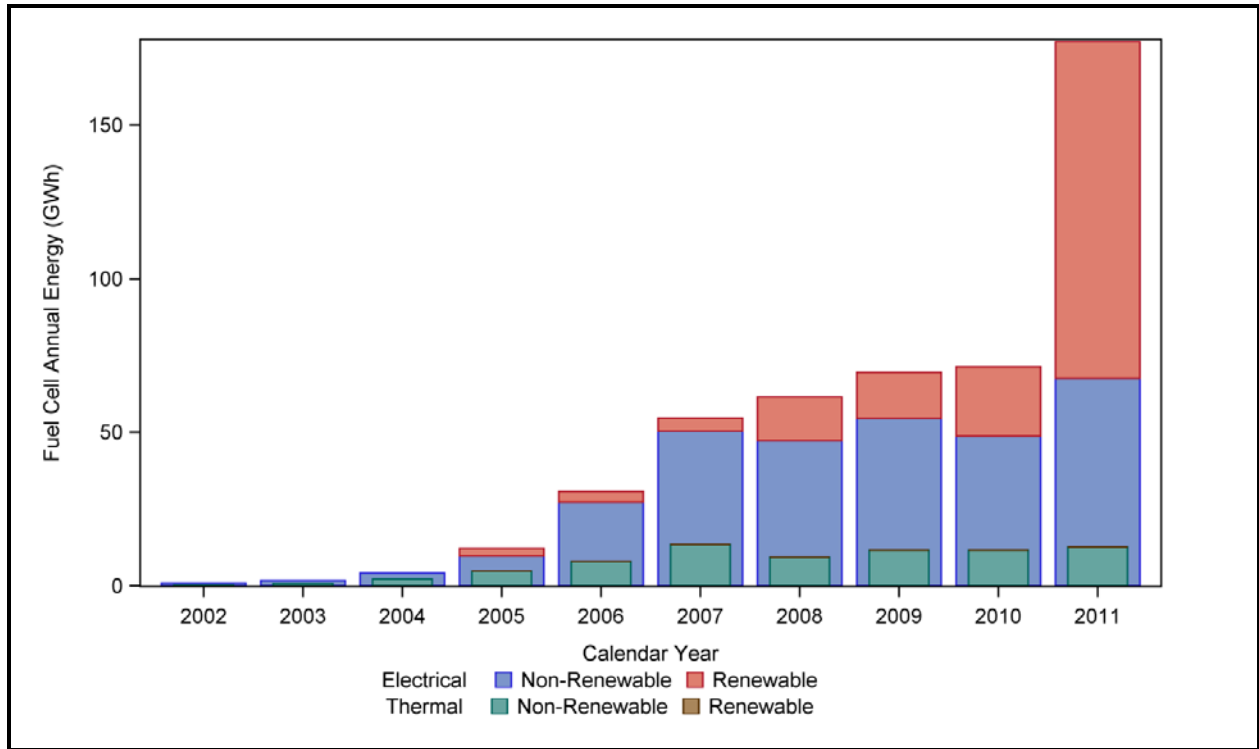
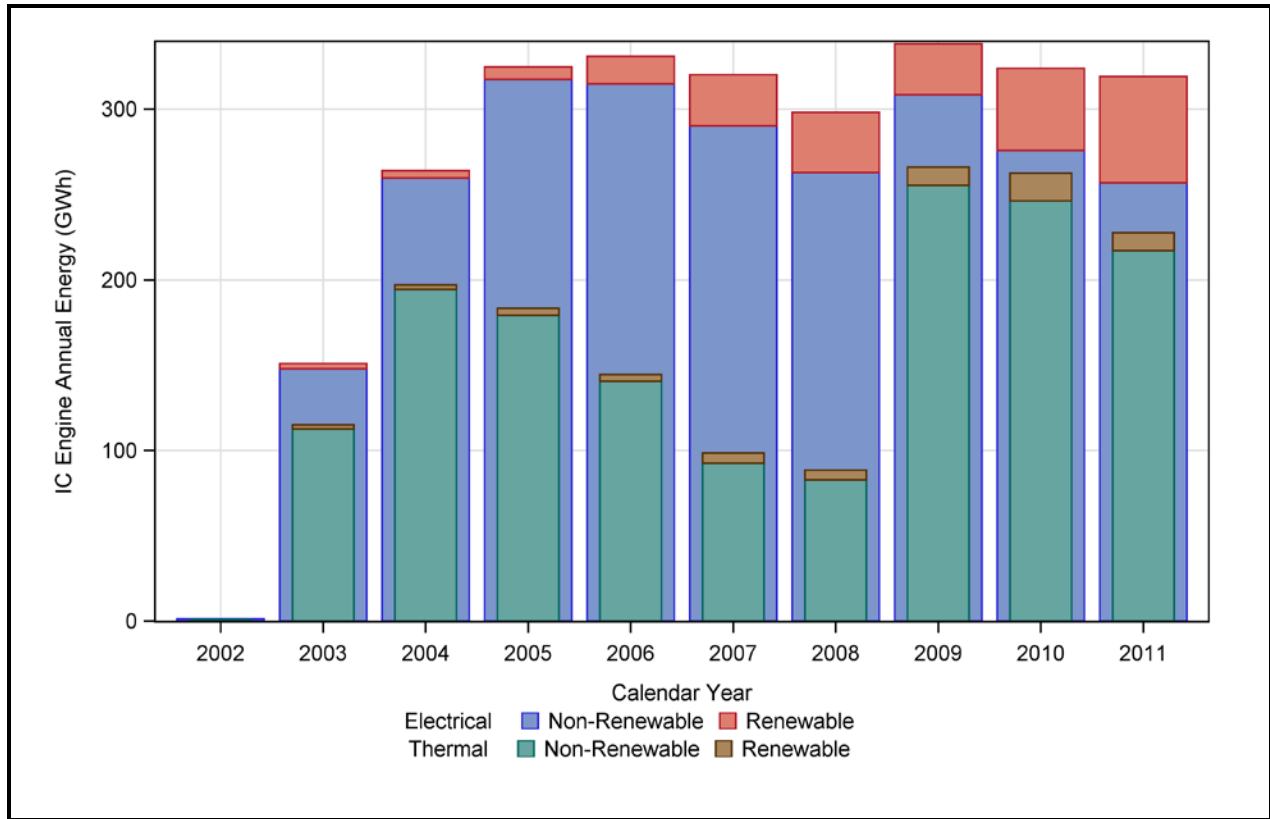


Figure 5-8 shows useful heat recovered from non-renewable projects in green. Useful heat recovered from renewable projects would be shown in brown. However, fuel cells using renewable fuels (including those using directed biogas) recovered no useful heat and so do not show up in the figure.

**Figure 5-9: Electrical and Thermal Energy by Year for IC Engines**



The color-coding in Figure 5-9 is the same as for Figure 5-8. The additional thermal energy provided by renewable-fuel IC engines compared to fuel cells is quite evident when comparing the two figures with IC engines producing 76% vs. fuel cells that produced only 7% additional energy beyond electricity in the form of useful heat.

## 5.6 Key Observations

A few key observations are evident from the heat and fuel data for SGIP projects in 2011:

- Useful waste heat recovery provides a significant amount of additional energy for SGIP projects. Increasing waste heat recovery could allow the program to better meet efficiency goals.
- Low electrical conversion efficiencies for some technologies, such as microturbines, make it difficult to meet overall project and program efficiency goals.
- Fuel cells could recover substantially more heat than they do currently. Increasing fuel cell heat recovery could substantially increase total program energy delivered and will help with greenhouse gas reductions.

# 6

## Greenhouse Gas Emission Impacts

---

### 6.1 Overview

Interest in climate change has continued to increase in recent years with special emphasis being placed on greenhouse gas (GHG) emission impacts. In its final Decision<sup>1</sup> modifying the SGIP and implementing Senate Bill 412,<sup>2</sup> the CPUC, for the first time, set GHG emission targets for all projects rebated by the SGIP. If California initiates the revenue aspects of the carbon cap and trade program in 2013<sup>3</sup> as expected, the importance of obtaining accurate measurements of GHG emissions and their reductions will become even greater. GHG emission impacts have been presented in SGIP impact reports since 2005. Over the years, the accuracy of GHG emission impact estimates have increased as calculation methods improved and more electrical and heat data became available.

This section presents the impacts of the installation of SGIP projects on GHG emissions in 2011. GHG impacts are examined by technology and fuel type, and use a baseline scenario as measured in CO<sub>2</sub> equivalent units to facilitate comparisons. This methodology allows examination of relationships between net changes in GHG emission impacts, technology, and fuel type. As in all prior SGIP Impact Evaluation Reports, the focus on GHG emission impacts is on carbon dioxide and methane (CO<sub>2</sub> and CH<sub>4</sub> respectively) as these are the main GHG emissions associated with SGIP projects and baseline scenarios.

### 6.2 GHG Analysis Approach

GHG emission impacts are calculated per SGIP project on an hourly net basis. The net basis is defined as the difference between the GHG emissions produced by the SGIP rebated distributed generation (DG) project and the baseline GHG emissions. Baseline GHG emissions are the sum of the emissions that would have occurred in the absence of the SGIP project. In particular,

---

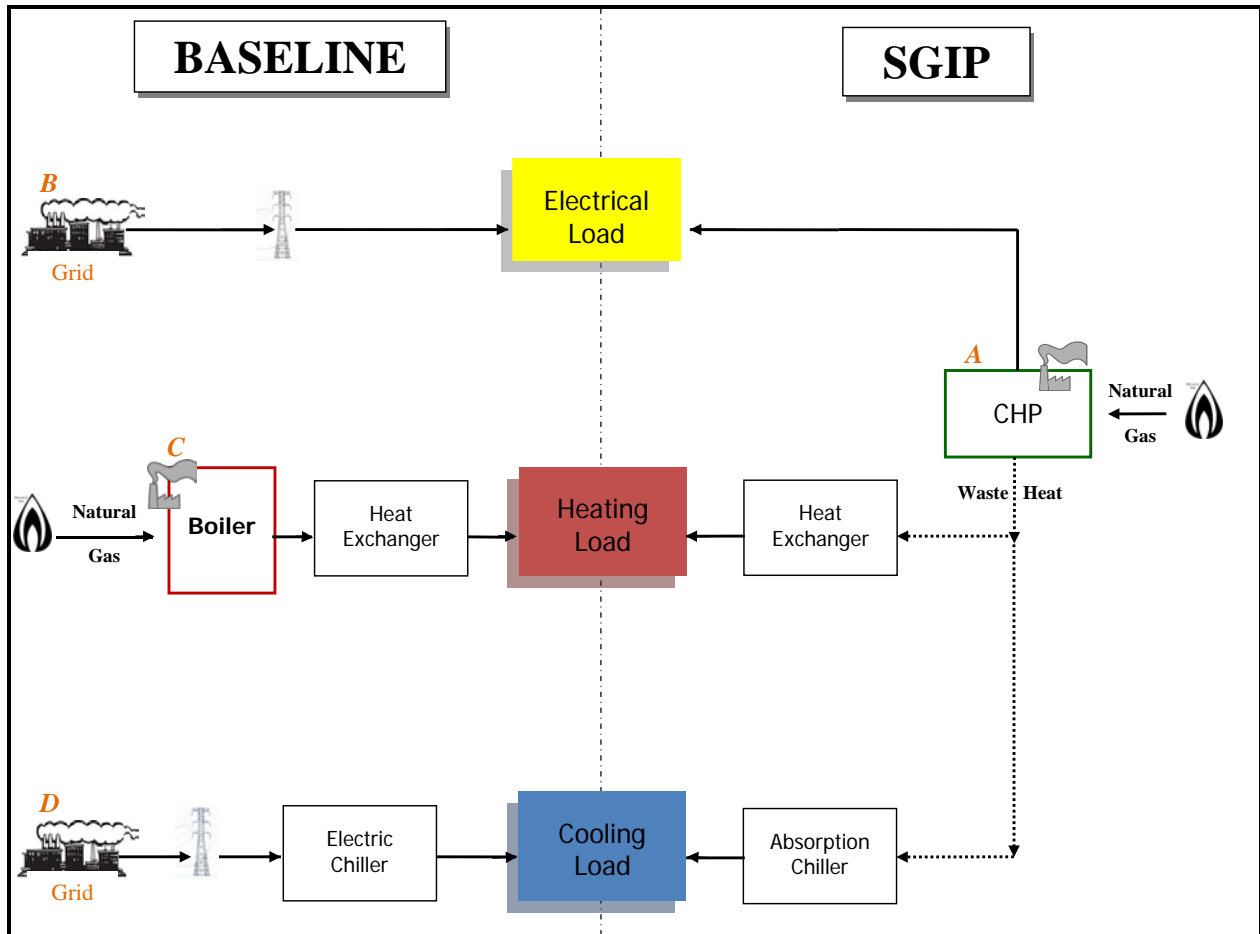
<sup>1</sup> CPUC D.11.09.015, September 8, 2011. [http://docs.cpuc.ca.gov/WORD\\_PDF/FINAL\\_DECISION/143459.PDF](http://docs.cpuc.ca.gov/WORD_PDF/FINAL_DECISION/143459.PDF)

<sup>2</sup> Senate Bill 412 (Kehoe, 2009): [http://www.leginfo.ca.gov/pub/09-10/bill/sen/sb\\_0401-0450/sb\\_412\\_bill\\_20091011\\_chaptered.pdf](http://www.leginfo.ca.gov/pub/09-10/bill/sen/sb_0401-0450/sb_412_bill_20091011_chaptered.pdf)

<sup>3</sup> California's carbon cap and trade program is an element of AB 32 (the California Global Warming Solutions Act of 2006). The California Air Resources Board adopted a cap and trade regulation in 2011. AB 1532 (Perez) establishes a market-based compliance and funding mechanism for the cap and trade program. The program is to be operational January 1, 2013.

baseline GHG emissions are those produced by the grid to satisfy electrical, heating, and cooling demands currently satisfied by the rebated DG project. The relationship between the SGIP system and the baseline assumptions as they relate to GHG impacts are depicted in Figure 6-1.

**Figure 6-1: GHG Impacts Assumptions for Non-renewable Systems**



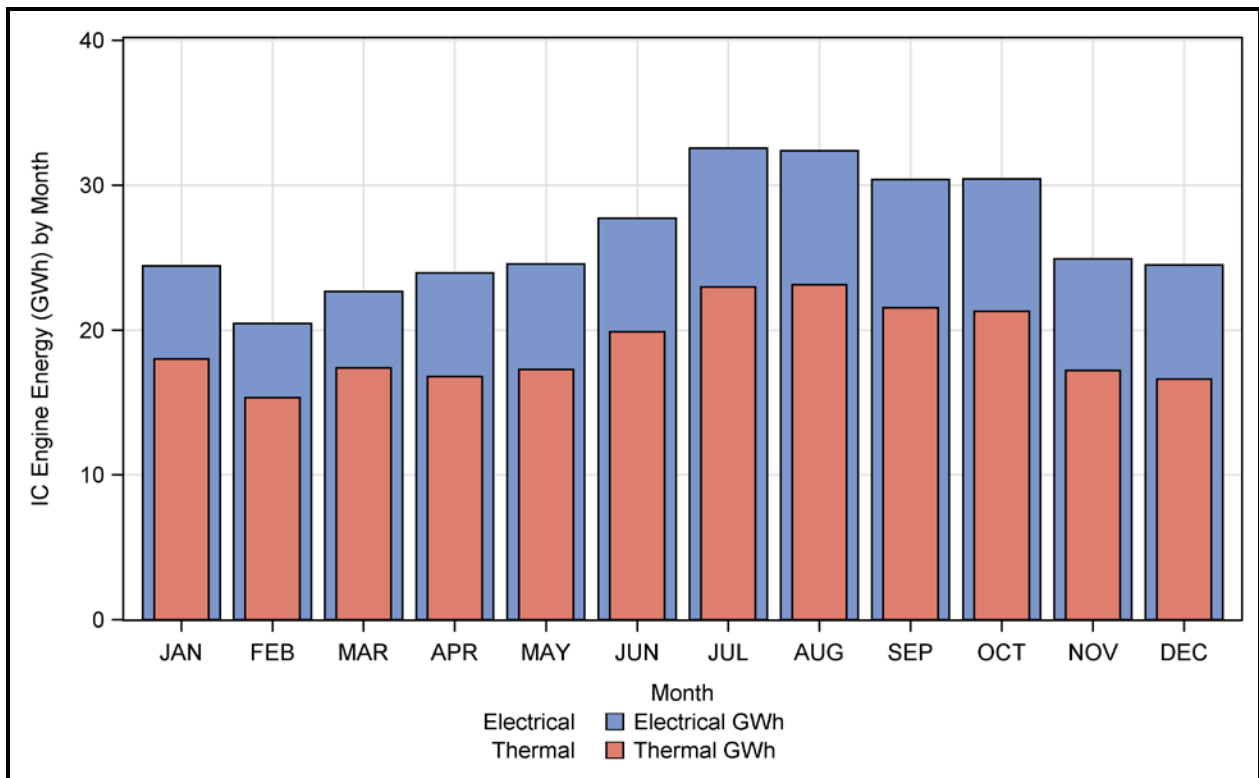
Three colored boxes representing a facility’s<sup>4</sup> electrical, heating, and cooling needs are drawn down the middle of Figure 6-1. The SGIP system is drawn on the right showing how each energy need is met by the DG system on-site. The electrical load is met directly by the SGIP generator, the heating load (if applicable) is met directly by waste heat from the generator, and the cooling load (again, if applicable) is met by using waste heat from the generator with an absorption chiller. Absorption chillers are similar to electric chillers but they use heat instead of electricity to provide cooling. The emissions associated with the SGIP project fulfilling all these loads are all due to the generator’s exhaust and will be referred to in subsequent tables and figures as “SGIP” emissions.

<sup>4</sup> Facilities refer to utility customers who are participating in the SGIP through use of a DG technology at their facility and which received an SGIP incentive.

On the left, our assumptions of how these same needs would have been met in the absence of the program are shown as the baseline scenario. The electrical load would have been met by grid electricity, the heating load would have been met by an on-site natural gas boiler, and the cooling load would have been met by a chiller that runs on electricity provided by the grid. Each component of the baseline has emissions associated with it. Grid generators (whether they are delivering electricity to fulfill an electrical or cooling load) and on-site boilers emit CO<sub>2</sub> one way or another.

The baseline value is not static; it changes every hour of every year based on annual energy production, rebated capacity, electrical efficiencies, and heat recovery rates. To illustrate this point, Figure 6-2 shows monthly energy (thermal and electrical) produced by IC engines in 2011.

**Figure 6-2: Monthly Energy Produced by IC Engines in 2011**



The energy produced by IC engines (or any other technology) is constantly changing. The baseline scenario changes accordingly because it always assumes that the facility would have generated the same amount of energy as the SGIP system. For example, in Figure 6-2 we see that electrical energy generated by IC engines in February (blue bar) total approximately 20 GWh compared to over 30 GWh in July. In this case, the electrical grid component of the baseline ('B' in Figure 6-1) would increase accordingly to reflect an equal amount of energy being generated by the grid. Again, energy delivered by the SGIP project is always assumed to

be exactly the same amount as the energy delivered under the baseline scenario; the only difference is the source (i.e., grid versus SGIP generator, on-site boiler versus waste heat recovery, etc.). Consequently, the emissions associated with the delivery of the energy differ for each scenario. For example, if an SGIP project recovers heat, that same amount of heat is assumed to be recovered in the baseline scenario. However, the CO<sub>2</sub> emissions associated with creating that heat (in a boiler vs. capturing waste heat) are not the same.

In the case of renewable (biogas)-fueled SGIP projects, baseline GHG emissions include an additional component associated with the treatment of the CH<sub>4</sub> gas prior to it being consumed in the SGIP project.

Not all of the baseline components apply to all projects and, at a minimum, depend on the SGIP project type. Table 6-1 shows which components are typically associated with SGIP projects by fuel type. Detailed documentation of the PY11 GHG emissions impact evaluation methodology is included as Appendix B.

**Table 6-1: Baseline CO<sub>2</sub> Emission Components by Fuel Type**

<b>Fuel Type</b>	<b>SGIP Project CO<sub>2</sub> Emissions</b>	<b>Electric Power Plant CO<sub>2</sub> Emissions</b>	<b>CO<sub>2</sub> Emissions Associated with Heating Services</b>	<b>CO<sub>2</sub> Emissions Associated with Cooling Services</b>	<b>CO<sub>2</sub> Emissions from Biogas Treatment</b>
Non-Renewable	<b>X</b>	<b>X</b>	<b>X</b>	<b>X</b>	
Renewable	<b>X</b>	<b>X</b>	<b>X</b>		<b>X</b>

**6.2.1 GHG Analysis Results**

Due to the varying number of baseline GHG emission components associated with each SGIP project, results for non-renewable DG facilities and renewable fuel (i.e., biogas-fueled) SGIP projects are presented independently. An overall summary of the total GHG emission impacts and Program Administrator (PA)-specific GHG emission impacts is presented at the end of this section.



Waste heat recovered for a heating end use (displacing a boiler) is more than six times more effective at reducing greenhouse gas emissions than waste heat recovered for a cooling end use (displacing a chiller). See Appendix B for a more detailed discussion of the GHG impacts methodology.

**CO<sub>2</sub> Emission Impacts from Non-renewable CHP Projects**

There are three sources of CO<sub>2</sub> emission impacts from non-renewable CHP projects. There are CO<sub>2</sub> emission impacts from direct displacement of grid-based electricity by the CHP generator. In addition, there are CO<sub>2</sub> emission impacts due to displacement of natural gas burned in boilers to provide on-site process heating. The natural gas



is displaced through capture and use of waste heat by the waste heat recovery system in the SGIP CHP project. Furthermore, some non-renewable CHP SGIP projects use recovered waste heat in absorption chillers to provide facility cooling. If the absorption chillers replaced electric chillers, then CO<sub>2</sub> emission impacts accrue from the displaced electricity that otherwise would have driven the electric chiller.

Table 6-2 provides a breakdown of CO<sub>2</sub> emissions associated with non-renewable SGIP projects and each of the baseline components (the letters underneath the headers in Table 6-2 and Table 6-3 match those drawn in Figure 6-1). Column ‘A’ represents the total emissions generated by SGIP projects; each row represents a specific non-renewable technology type. In general, SGIP CO<sub>2</sub> emissions are related to two factors, the total rebated on-line capacity and the technology’s observed electrical efficiency. If there are more projects installed (hence greater total installed capacity), these projects will consume (and burn) more natural gas. Furthermore, if a technology type is less efficient, it will burn more natural gas to generate electricity. Column ‘B’ represents emissions the grid would have emitted generating the same electricity produced by the SGIP project.

Columns ‘C’ and ‘D’ represent the emissions that would have occurred in the absence of the SGIP. Column “C” represents the emissions associated with meeting the facility’s heating load in the absence of the SGIP project; likely through an on-site boiler. Column “D” represents the emissions associated with meeting the facility’s cooling load; maybe through an electric chiller. The CO<sub>2</sub> emission values in columns “C” and “D” represent baseline emissions avoided by the SGIP project. As the SGIP project recovers more useful heat which is used for on-site heating and cooling needs, the SGIP avoids more emissions for the displaced boiler and chiller operation and the values in columns ‘C’ and ‘D’ will increase. Total baseline emissions (column ‘E’) are the total emissions (electrical, heating, and cooling) that would have occurred in the absence of the program. The difference between SGIP emissions and the total baseline emissions (column ‘F’) represents the net impacts of the SGIP. Table 6-2 provides the results by technology type for non-renewable projects.

In 2011, the net GHG impact of all non-renewable technologies was a 48,756 ton increase in CO<sub>2</sub> emissions. This represents the CO<sub>2</sub> emissions added by the deployment of non-renewable SGIP projects. In 2010, the program GHG impact from non-renewable SGIP projects was a net increase in 50,107 tons of CO<sub>2</sub> emissions. This 17% decrease between 2011 and 2010 may be attributed to an increase in the total number of projects entering the program with high electrical efficiencies and greater useful heat recovery rates.

**Table 6-2: CO<sub>2</sub> Emission Impacts from Non-renewable Projects in 2011**

Type	SGIP Emissions (Metric Tons of CO <sub>2</sub> per Year) A	Baseline Emissions (Metric Tons of CO <sub>2</sub> per Year)				GHG Emissions Impact (Metric Tons of CO <sub>2</sub> per Year) F=A-E
		Electric Power Plant B	Heating Services C	Cooling Services D	Total Baseline E=B+C+D	
FC - CHP	23,522	20,126	2,487	32	22,645	877
FC - Elec.	7,561	7,811	0	0	7,811	-250
FC - PEM	656	529	67	0	596	61
GT	111,071	78,780	12,218	2,002	93,000	18,071
ICE	157,237	109,878	33,038	2,861	145,778	11,459
MT	58,447	29,949	9,430	529	39,908	18,539
<b>Total</b>	<b>358,495</b>	<b>247,073</b>	<b>57,240</b>	<b>5,425</b>	<b>309,738</b>	<b>48,756</b>

Electric-only fuel cells were the only non-renewable technology that had a net-reducing effect on GHG emissions for the SGIP in 2011, shown by a negative value in column ‘F’. Despite not recovering heat, the electrical efficiency of these fuel cells is greater than grid-delivered electricity (shown by column ‘A’ being slightly less than column ‘B’).

Table 6-2 also illustrates the importance of heating and cooling services on GHG emissions for CHP projects. In particular, baseline heating and cooling services combined accounted for over 62,000 metric tons of CO<sub>2</sub> emissions in 2011. The baseline CO<sub>2</sub> emissions associated with heating services for IC engines are much higher than those seen for microturbines. This is consistent with the higher heat recovery rates of IC engines shown in Section 5.

Comparisons can be made between different CHP technologies by normalizing the CO<sub>2</sub> emission impacts by the annual energy production. This approach eliminates the effects of total capacity (i.e., more systems versus. less systems) and presents the CO<sub>2</sub> impacts as rates. Table 6-3 and Figure 6-3 present the annual CO<sub>2</sub> impacts in metric tons of CO<sub>2</sub> per MWh of electricity generated for non-renewable technologies. Again, net positive CO<sub>2</sub> impacts represent an increase in CO<sub>2</sub> resulting from installation of non-renewable SGIP projects.

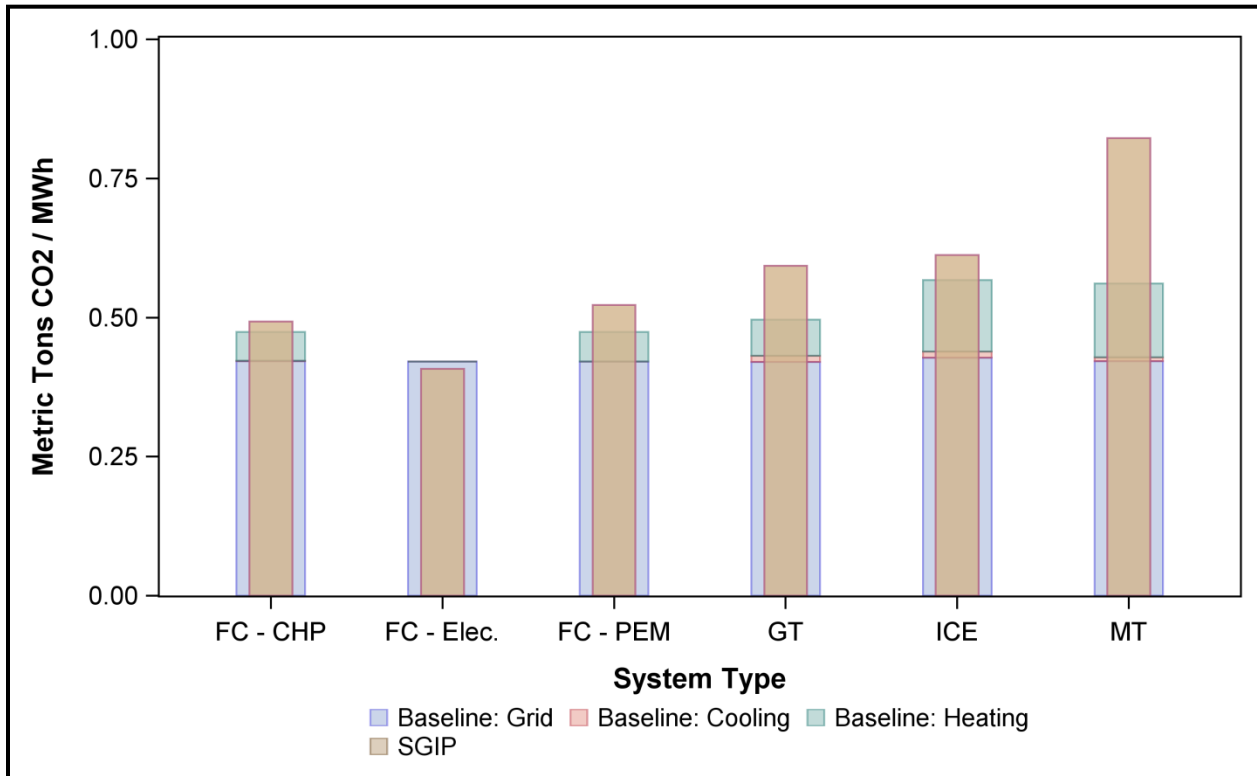
**Table 6-3: CO<sub>2</sub> Emission Rates for Non-renewable Projects in 2011**

Type	SGIP Emissions (Metric Tons of CO <sub>2</sub> per MWh) A	Baseline Emissions (Metric Tons of CO <sub>2</sub> per MWh)				GHG Emissions Impact (Metric Tons of CO <sub>2</sub> per MWh) F=A-E	Annual Energy Produced (MWh)
		Electric Power Plant B	Heating Services C	Cooling Services D	Total Baseline E=B+C+D		
FC - CHP	0.49	0.42	0.05	0.00	0.47	0.02	47,759
FC - Elec.	0.41	0.42	0.00	0.00	0.42	-0.01	18,550
FC - PEM	0.52	0.42	0.05	0.00	0.47	0.05	1,257
GT	0.59	0.42	0.07	0.01	0.50	0.10	187,345
ICE	0.61	0.43	0.13	0.01	0.57	0.04	256,899
MT	0.82	0.42	0.13	0.01	0.56	0.26	71,079

Table 6-3 makes it clear that electric only fuel cells reduce GHG emission because their emissions rate (column ‘A’) is less than the annual average emissions rate of the grid (column ‘B’). In other words, electric only fuel cells reduced GHG emissions because they were, on average, more efficient than the grid at producing electricity in 2011. In order for other non-renewable technologies to reduce GHG emissions, they must find ways to offset the fact that they are less efficient than the grid at generating electricity. This can be achieved by capturing “free” waste heat and using it to offset heating and cooling loads. Non-renewable CHP technologies in the SGIP were not able to achieve this in 2011.

Figure 6-3 shows the same information as Table 6-3 but in a form that may be easier to interpret. The narrow brown bars in the foreground represent CO<sub>2</sub> emission rates from SGIP systems. The wide blue bars in the background represent the CO<sub>2</sub> emission rates from the grid. If the narrow brown bar is higher than the wide blue bar, then the SGIP system emits more CO<sub>2</sub> than the grid to generate the same amount of electricity. This may be offset by recovering “free” waste heat for heating (wide green bar) and cooling (wide red bar) services. The three wide bars all add up to the total baseline – if the narrow brown bar is still higher than the total baseline, then the SGIP is still a net emitter of GHG emissions. Again, Figure 6-3 tells us that electric only fuel cells were the only non-renewable technology that reduced GHG emissions, shown by the narrow brown bar being lower than the wide bars (total baseline).

**Figure 6-3: CO<sub>2</sub> Emission Rates for Non-renewable Projects in 2011**



**GHG Emission Impacts (CO<sub>2</sub> and CH<sub>4</sub>) from Renewable (Biogas) Projects**

Renewable fueled projects in the SGIP include wind projects and projects that use biogas as a fuel resource. Sources of biogas include landfills, wastewater treatment plants (WWTP), anaerobic digesters located at dairies and digesters located at food processing facilities. Analysis of the GHG emission impacts associated with fuel cells, microturbines, and IC engines using renewable biogas is more complex than for non-renewable projects. This complexity is due, in part, to the additional baseline GHG component associated with biogas collection and treatment prior to the SGIP project installation. In addition, some projects generate only electricity while others are CHP projects that use waste heat to meet facility heating and cooling loads. Consequently, renewable projects can directly impact CO<sub>2</sub> emissions the same way that non-renewable projects can, but they also include GHG emission impacts caused by captured CH<sub>4</sub> contained in the biogas.



Landfill gas, consisting primarily of methane, is produced via biological breakdown of waste material. Methane is required to be combusted (flared) before being released to the atmosphere for safety and environmental reasons. Methane has a high GHG potential and is highly flammable.

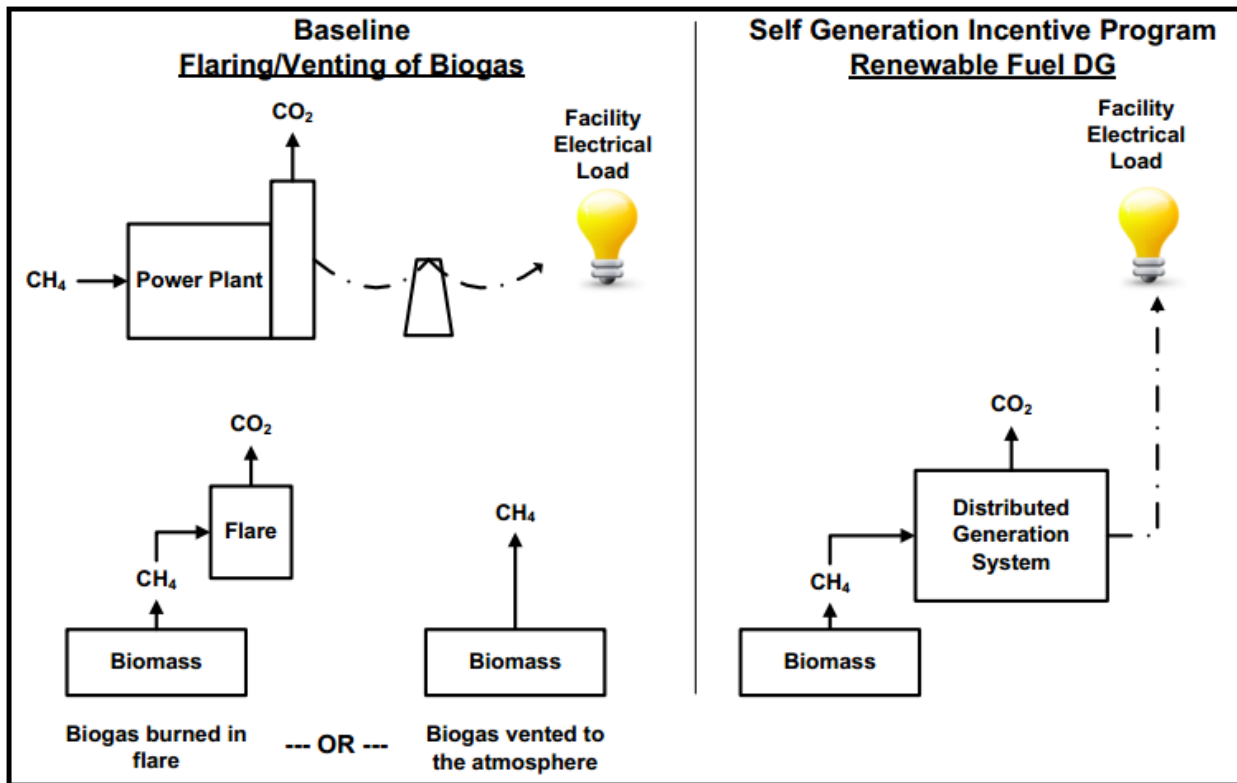
Renewable biogas SGIP projects capture and use CH<sub>4</sub> that otherwise may have been emitted into the atmosphere (vented) or captured and burned (flared). Venting and flaring will hereafter be referred to as the biogas baseline. The concept of a biogas baseline is depicted in Figure 6-4.



Animal waste from dairies and other livestock is often disposed of in man-made lagoons. Within these lagoons the waste undergoes a biological process that converts the waste into methane. This methane is often allowed to vent to the atmosphere.

When reporting emissions impacts from different types of greenhouse gases, total GHG emissions are reported in terms of tons of CO<sub>2</sub> equivalent (CO<sub>2</sub>Eq) so that direct comparisons can be made to other components of the baseline. The global warming potential of CH<sub>4</sub> is 21 times that of CO<sub>2</sub>. The biogas baseline estimates of vented emissions (CH<sub>4</sub> emission impacts from renewable SGIP facilities) are converted to CO<sub>2</sub>Eq by multiplying the quantity of CH<sub>4</sub> by 21. In the following tables, CO<sub>2</sub>Eq emissions are reported if projects with a biogas baseline of venting are included, otherwise, CO<sub>2</sub> emissions are reported.

**Figure 6-4: GHG Emission Impacts Associated with On-site Renewable DG**



Prior to the 2009 impact report, we made several critical assumptions about the baseline conditions of renewable biogas projects in the absence of the SGIP. We assumed that all landfill gas facilities were assumed to have captured and flared CH<sub>4</sub>; all dairies were assumed to have vented CH<sub>4</sub>, and other digesters were assumed to have vented digester gas if they were under 150 kW of rebated capacity and flared the digester gas if they were 150 kW or greater in rebated capacity. Starting in 2009 with new information gathered from SGIP facilities, all facilities except dairies were assumed to capture and flare methane. In general, by changing this assumption, the number of sites venting CH<sub>4</sub> was reduced starting in PY09 when compared to the impact reports of 2008 and prior. The effect has been an overall reduction in GHG impact of renewable fueled SGIP projects because CH<sub>4</sub> has a higher global warming potential than CO<sub>2</sub>.

In CPUC Decision 09-09-048 (September 24, 2009), eligibility for renewable fuel use incentives was expanded to include “directed biogas” projects. Deemed to be renewable fuel use projects, directed biogas projects are eligible for higher incentives under the SGIP. Directed biogas projects purchase biogas fuel that is produced at another location. The procured biogas is processed, cleaned-up, and injected into a natural gas pipeline for distribution. Although the purchased gas is not likely to be delivered and used at the SGIP renewable-fuel-use project, directed biogas projects are treated in the SGIP as renewable-fuel-use projects.

Historically, on-site renewable fuel facilities such as landfills and wastewater treatment plants have been surveyed to determine the renewable fuel baseline (i.e., to determine if the biogas would be vented or flared in the absence of the program). For directed biogas projects where the biogas is injected into the pipeline outside of California, information on the renewable fuel baseline was not available.<sup>5</sup> However, it is clear that SGIP projects are consuming some amount of directed biogas, which ultimately was derived from biogas sources. To establish a directed biogas baseline, we made the following assumptions in the absence of specific consumption data:

1. The renewable fuel baseline for all directed biogas projects is flaring of biogas,<sup>6</sup> and
2. Seventy five percent of the energy consumed by directed biogas facilities on an energy basis (the minimum amount of biogas required to be procured by a directed biogas project) is assumed to have been injected at the biogas source.<sup>7</sup>

A summary per facility type of the biogas baseline assumptions is shown in Table 6-4.

---

<sup>5</sup> Information on consumption of directed biogas at SGIP projects is based on invoices instead of metered data.

<sup>6</sup> From a financial feasibility perspective, directed biogas was assumed to be procured only from large biogas sources, such as large landfills. In accordance with Environmental Protection Agency regulations for large landfills, these landfills would have been required to collect the landfill gas and flare it. As a result, the basis for directed biogas projects was assumed to be flaring.

<sup>7</sup> As noted earlier, information on directed biogas consumption by SGIP projects is limited to invoices, which have not been validated by metered data on the actual amounts of biogas injected into natural gas pipelines.

**Table 6-4: Biogas Baseline Assumption**

Renewable Fuel Source	Facility Type*	Size of Rebated Project (kW)	Impact Report	
			PY07-08	PY09-11
Digester Gas	WWTP	<150	Vent	Flare
		≥150	Flare	Flare
Digester Gas	Food Processing	<150	Vent	Flare
		≥150	Flare	Flare
Landfill Gas	LFG	All Sizes	Flare	Flare
Directed Biogas	LFG	All Sizes	N/A	Flare
Digester Gas	Dairy	All Sizes	Vent	Vent

Flaring CH<sub>4</sub> (which converts CH<sub>4</sub> to CO<sub>2</sub>) is assumed to result in the same amount of CO<sub>2</sub> emissions that would occur if the CH<sub>4</sub> was captured and used by the SGIP project. The total electricity generated by these SGIP projects was used to calculate the total CH<sub>4</sub> emissions avoided by relying upon that CH<sub>4</sub> to generate power at these SGIP projects. Of the biogas projects that were assumed to have vented CH<sub>4</sub> prior to participation in the SGIP, all were IC engine facilities. A more detailed discussion of the biogas baseline component is presented in Appendix B.

Table 6-5 and Table 6-6 provide the GHG emission impacts occurring from renewable biogas projects. Separate tables are shown for the flaring and venting CH<sub>4</sub> baseline, as venting CH<sub>4</sub> results are provided in tons of CO<sub>2</sub>Eq, and flaring CH<sub>4</sub> results are given as tons of CO<sub>2</sub>. Tons of CO<sub>2</sub>Eq results can be directly compared to all other results given in tons of CO<sub>2</sub>. Projects that previously flared biogas had a net reducing impact of 65,872 metric tons of CO<sub>2</sub> in 2011.

The importance of the biogas baseline component is immediately apparent from Table 6-5. All renewable technologies with a flaring baseline component were net-reducers of GHG. In essence, this means that running a CHP system at a facility that was flaring biogas does not generate any extra CO<sub>2</sub> emissions because the gas was going to be burned anyway. This result is shown by column ‘A’ almost always being equal to column ‘D’, except for fuel cells where we assume that directed biogas projects are only avoiding 75% of the on-site gas use on an energy basis.

**Table 6-5: CO<sub>2</sub> Emission Impacts from Biogas Projects in 2011 - Flared CH<sub>4</sub> Baseline**

Type	SGIP Emissions (Metric Tons of CO <sub>2</sub> per Year) A	Baseline Emissions (Metric Tons of CO <sub>2</sub> per Year)				GHG Emissions Impact (Metric Tons of CO <sub>2</sub> per Year) F=A-E
		Electric Power Plant B	Heating Services C	Biogas Treatment D	Total Baseline E=B+C+D	
FC	47,210	46,203	0	39,084	85,287	-38,077
ICE	33,935	23,394	2,198	33,935	59,527	-25,592
MT	4,064	2,089	114	4,064	6,267	-2,203
<b>Total</b>	<b>85,209</b>	<b>71,685</b>	<b>2,312</b>	<b>77,083</b>	<b>151,081</b>	<b>-65,872</b>

Table 6-6 includes the CH<sub>4</sub> emission impacts and equivalent CO<sub>2</sub> emission impacts from the biogas facilities that previously vented CH<sub>4</sub>. A quick comparison of column ‘A’ and column ‘E’ shows that venting CH<sub>4</sub> (CO<sub>2</sub>Eq Emissions (converted from CH<sub>4</sub>)) produces CO<sub>2</sub>Eq emissions that are an order of magnitude greater than the electric power plant GHG emissions or the SGIP project emissions. Projects that previously vented biogas had a net reducing impact of 29,777 metric tons of CO<sub>2</sub> in 2011.

**Table 6-6: CO<sub>2</sub> (and CO<sub>2</sub>Eq) Emission Impacts from Biogas Projects in 2011 - Vented CH<sub>4</sub> Baseline**

Type	SGIP CO <sub>2</sub> Emissions (Metric Tons of CO <sub>2</sub> per Year) A	Baseline Emissions (Metric Tons of CO <sub>2</sub> per Year)				GHG Emissions Impact (Metric Tons of CO <sub>2</sub> per Year) F=A-E
		Electric Power Plant Emissions B	Heating Services C	CO <sub>2</sub> Emissions from Biogas Treatment D	Total Baseline Emissions E=B+C+D	
ICE	4,063	2,795	0	31,045	33,840	-29,777

Table 6-7 shows emission rates of biogas projects that are assumed to have flared CH<sub>4</sub>. These CO<sub>2</sub> emission rates shown in column ‘F’ are substantially larger (i.e. more reducing) than those achieved by their natural gas counterparts described in Table 6-3. In terms of the total SGIP GHG emission rates, flaring biogas offsets the emissions from the SGIP project.



**Table 6-7: CO<sub>2</sub> Emission Rates from Biogas Projects in 2011 - Flared CH<sub>4</sub> Baseline**

Type	SGIP CO <sub>2</sub> Emissions (Metric Tons of CO <sub>2</sub> per MWh) A	Baseline Emissions (Metric Tons of CO <sub>2</sub> per MWh)				GHG Emissions Impact (Metric Tons of CO <sub>2</sub> per MWh) F=A-E	Annual Energy Produced (MWh)
		Electric Power Plant Emissions B	Heating Services C	CO <sub>2</sub> Emissions from Biogas Treatment D	Total Baseline Emissions E=B+C+D		
FC	0.43	0.42	0.00	0.36	0.78	-0.35	109,602
ICE	0.61	0.42	0.04	0.61	1.07	-0.46	55,444
MT	0.82	0.42	0.02	0.82	1.27	-0.45	4,943

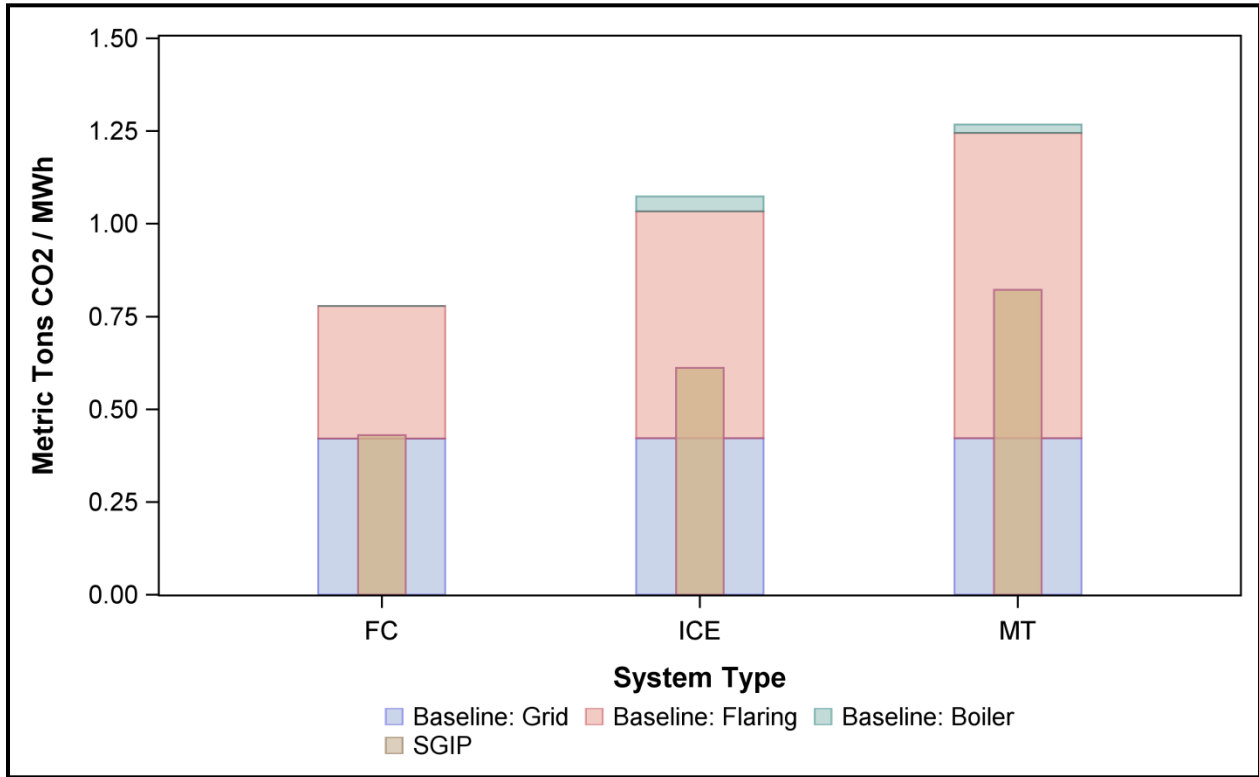
Table 6-8 shows the emission rates of biogas projects that are assumed to have vented CH<sub>4</sub> as part of the baseline. The annual CO<sub>2</sub>Eq impacts associated with SGIP projects that previously vented CH<sub>4</sub> are much larger than the annual CO<sub>2</sub> impacts for projects that previously captured and flared CH<sub>4</sub> because, again, the global warming potential of CH<sub>4</sub> is 21 times that of CO<sub>2</sub>. Therefore, offering an incentive program that encourages biogas facility owners currently venting CH<sub>4</sub> to install a biogas project could have very large impacts on GHG emissions.

**Table 6-8: CO<sub>2</sub> (and CO<sub>2</sub>Eq) Emission Rates from Biogas Projects in 2011 – Vented CH<sub>4</sub> Baseline**

Type	SGIP CO <sub>2</sub> Emissions (Metric Tons of CO <sub>2</sub> per MWh) A	Baseline Emissions (Metric Tons of CO <sub>2</sub> per MWh)				GHG Emissions Impact (Metric Tons of CO <sub>2</sub> per MWh) F=A-E	Annual Energy Produced (MWh)
		Electric Power Plant Emissions B	Heating Services C	CO <sub>2</sub> Emissions from Biogas Treatment D	Total Baseline Emissions E=B+C+D		
ICE	0.61	0.42	0.00	4.68	5.10	-4.5	6,638

Figure 6-5 and Figure 6-6 show the biogas emission rates of flared and vented CH<sub>4</sub> projects, respectively.

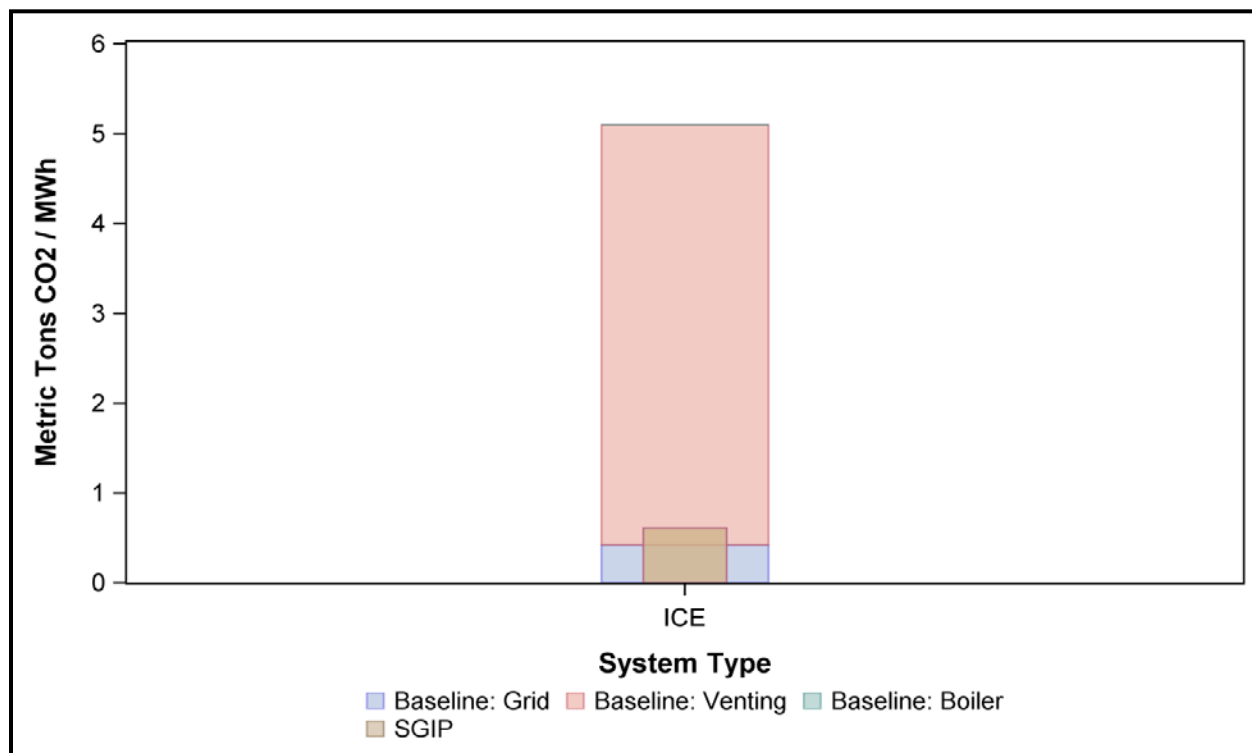
**Figure 6-5: CO<sub>2</sub> Emission Rates from Biogas Projects in 2011 - Flared CH<sub>4</sub> Baseline**



In Figure 6-5 we can once again compare the SGIP emission rate (narrow brown bar) to the total baseline emission rate (wide background bar). The first thing we see is that all technologies with a flaring baseline are reducing GHG emissions, indicated by the narrow brown bar being shorter than the wide background bars. Looking closely we see that although these technologies are less efficient than the grid at generating electricity (brown bar is taller than blue bar); the fact that they are offsetting a flaring baseline (red background bar) makes them net GHG reducers. We also see some additional benefits from heating services (green bar) with IC engines and microturbines. Although DG technologies powered by renewable fuels are not required to collect heat, doing so can provide additional GHG reductions. The bigger the gap between the brown bar and the background bars, the higher the rate of GHG reductions.

Figure 6-6 is similar to Figure 6-5 but deals with projects with a venting baseline. Only IC engines are installed at sites with a venting baseline. The first thing that one must pay attention to in Figure 6-6 is the scale of the vertical axis. While facilities with flaring baselines had baseline emission rates of about 0.75 – 1.25 metric tons of CO<sub>2</sub> per MWh, IC engines with a venting baseline have a baseline emission rate closer to 5 tons of CO<sub>2</sub> per MWh. This difference is due to the higher GHG potential of vented CH<sub>4</sub> compared to CO<sub>2</sub>.

**Figure 6-6: CO<sub>2</sub> (and CO<sub>2</sub>Eq) Emission Rates from Biogas Projects in 2011 – Vented CH<sub>4</sub> Baseline**



**Total GHG Emission Impacts**

Table 6-9 presents a summary of GHG emission impacts from the installation of all SGIP projects, measured in tons of CO<sub>2</sub> equivalent and broken down by the different SGIP technologies. During the 2011 program year, the total GHG emission impacts calculated for all SGIP projects was a net decrease of 46,893 tons of CO<sub>2</sub>Eq.

**Table 6-9: CO<sub>2</sub> (and CO<sub>2</sub>Eq) Emission Impacts from All SGIP Projects in 2011**

Type	SGIP CO <sub>2</sub> Emissions (Metric Tons of CO <sub>2</sub> per Year) A	Baseline Emissions (Metric Tons of CO <sub>2</sub> per Year)					GHG Emissions Impact (Metric Tons of CO <sub>2</sub> per Year) G=A-F
		Electric Power Plant Emissions B	Heating Services C	Cooling Services D	CO <sub>2</sub> Emissions from Biogas Treatment E	Total Baseline Emissions F=B+C+D+E	
FC	78,949	74,669	2,554	32	39,084	116,339	-37,390
GT	111,071	78,780	12,218	2,002	0	93,000	18,071
ICE	195,234	136,066	35,237	2,861	64,980	239,144	-43,910
MT	62,512	32,038	9,545	529	4,064	46,176	16,336
<b>Total</b>	<b>447,766</b>	<b>321,553</b>	<b>59,553</b>	<b>5,425</b>	<b>108,128</b>	<b>494,659</b>	<b>-46,893</b>

Fuel cells and IC engines were the only technologies that, as a group (including renewable and non-renewable projects), reduced GHG emissions. This is shown in Table 6-9 by negative values in column ‘G’. On the other hand, gas turbines and microturbines increased net GHG impacts compared to the baseline scenario.



In 2011, the SGIP reduced GHG emissions by over forty six thousand tons of CO<sub>2</sub>. This is equivalent to taking more than nine thousand cars off the road for an entire year.

Table 6-10 shows the same results summarized by technology and fuel. Looking first at fuel cells, we see that while Table 6-2 showed that electric only non-renewable fuel cells reduced GHG emissions, the reductions were not large relative to the emissions of other types of non-renewable fuel cells. In particular, while electric only non-renewable fuel cells reduced GHG emission impacts, the group of all non-renewable fuel cells increased GHG emissions. IC engines were the only other technology group to decrease GHG emissions, primarily due to the contribution of projects with flaring and venting biogas baselines. Gas turbines and microturbines on the other hand created net positive GHG emission impacts.

The overall net emission rate of the SGIP was a decrease of 0.06 metric tons of CO<sub>2</sub> per MWh generated in 2011. In other words, on average, every MWh of generation from the SGIP program had the effect of reducing GHG emissions by 0.06 metric tons of CO<sub>2</sub>.

**Table 6-10: CO<sub>2</sub> (and CO<sub>2</sub>Eq) Emission Impacts and Emission Rates from all SGIP Projects in 2011 by Type and Fuel**

Technology and Fuel	Annual GHG Emissions Impact (Metric Tons of CO <sub>2</sub> )	Annual Energy Impact (MWh)	GHG Emissions Impact (Metric Tons of CO <sub>2</sub> per MWh)
<b>FC</b>	<b>-37,390</b>	<b>177,168</b>	<b>-0.21</b>
Biogas-Directed	-25,534	79,740	-0.32
Biogas-Flared	-12,543	29,862	-0.42
NatGas	687	67,566	0.01
<b>GT</b>	<b>18,071</b>	<b>187,345</b>	<b>0.10</b>
NatGas	18,071	187,345	0.10
<b>ICE</b>	<b>-43,910</b>	<b>318,981</b>	<b>-0.14</b>
Biogas-Flared	-25,592	55,444	-0.46
Biogas-Vented	-29,777	6,638	-4.5
NatGas	11,459	256,899	0.04
<b>MT</b>	<b>16,336</b>	<b>76,022</b>	<b>0.21</b>
Biogas-Flared	-2,203	4,943	-0.45
NatGas	18,539	71,079	0.26
<b>Total</b>	<b>-46,893</b>	<b>759,515</b>	<b>-0.06</b>

**GHG Emission Impacts by Program Administrator and Location**

The previous section provided GHG emission estimates across the entire SGIP. This section presents information on the emissions of SGIP projects at the PA level. Table 6-11 presents a summary of CO<sub>2</sub> emission reductions in 2011 by PA and technology type.

**Table 6-11: CO<sub>2</sub> (and CO<sub>2</sub>Eq) Emission Impacts from all SGIP Projects in 2011 by PA and Technology Type**

Program Administrator and Technology Type	Total GHG Emissions (Metric Tons of CO <sub>2</sub> )	Total Baseline Emissions (Metric Tons of CO <sub>2</sub> )	Net GHG Emissions (Metric Tons of CO <sub>2</sub> )
<b>CCSE</b>	<b>61,043</b>	<b>52,341</b>	<b>8,702</b>
FC	5,449	6,911	-1,462
GT	45,104	33,655	11,449
ICE	8,130	9,336	-1,206
MT	2,360	2,439	-79
<b>PG&amp;E</b>	<b>178,555</b>	<b>223,411</b>	<b>-44,856</b>
FC	43,371	60,645	-17,274
GT	11,465	9,833	1,632
ICE	87,540	125,340	-37,800
MT	36,179	27,593	8,585
<b>SCE</b>	<b>51,007</b>	<b>61,029</b>	<b>-10,022</b>
FC	11,857	19,579	-7,722
ICE	31,082	35,779	-4,697
MT	8,068	5,671	2,397
<b>SCG</b>	<b>157,161</b>	<b>157,878</b>	<b>-716</b>
FC	18,271	29,204	-10,932
GT	54,503	49,512	4,991
ICE	68,482	68,689	-207
MT	15,905	10,473	5,432
<b>Total</b>	<b>447,766</b>	<b>494,659</b>	<b>-46,893</b>

SGIP projects administered by PG&E, SCE, and SoCal Gas had a net reducing effect on GHG emissions. Fuel cells and IC engines were primarily responsible for offsetting the increased emissions of other technologies, although microturbines administered by CCSE produced a small reduction in GHG emissions. Table 6-12 presents a summary of CO<sub>2</sub> emission impacts in 2011 by PA and fuel type.

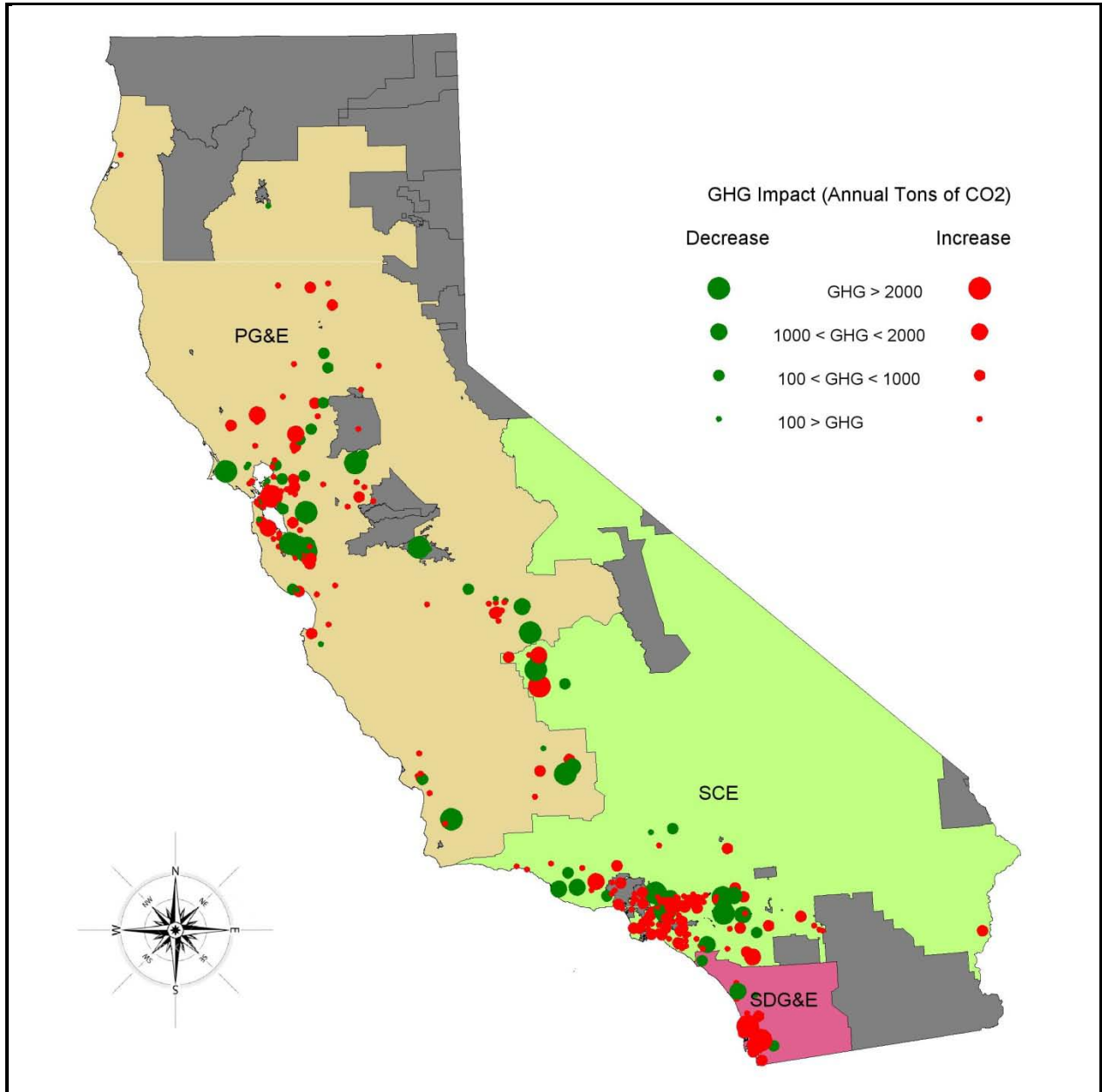
**Table 6-12: CO<sub>2</sub> (and CO<sub>2</sub>Eq) Emission Impacts from all SGIP Projects in 2011 by PA and Fuel Type**

Program Administrator and Fuel Type	Total GHG Emissions (Metric Tons of CO <sub>2</sub> )	Total Baseline Emissions (Metric Tons of CO <sub>2</sub> )	Net GHG Emissions (Metric Tons of CO <sub>2</sub> )
<b>CCSE</b>	<b>61,043</b>	<b>52,341</b>	<b>8,702</b>
Biogas-Directed	2,123	3,782	-1,659
Biogas-Flared	3,602	6,036	-2,433
NatGas	55,318	42,523	12,795
<b>PG&amp;E</b>	<b>178,555</b>	<b>223,411</b>	<b>-44,856</b>
Biogas-Directed	19,862	35,479	-15,617
Biogas-Flared	20,061	35,140	-15,079
Biogas-Vented	4,063	33,840	-29,777
NatGas	134,569	118,952	15,617
<b>SCE</b>	<b>51,007</b>	<b>61,029</b>	<b>-10,022</b>
Biogas-Directed	5,000	8,942	-3,943
Biogas-Flared	13,734	24,731	-10,997
NatGas	32,273	27,356	4,917
<b>SCG</b>	<b>157,161</b>	<b>157,878</b>	<b>-716</b>
Biogas-Directed	5,517	9,832	-4,315
Biogas-Flared	15,309	27,137	-11,828
NatGas	136,335	120,908	15,427
<b>Total</b>	<b>447,766</b>	<b>494,659</b>	<b>-46,893</b>

If climate change continues to remain an area of increasing concern, methods for achieving GHG emission reductions will increase in importance. It may also become vital to identify cost-effective ways to combine GHG emission reduction measures, including combining these measures at the same project sites. As a result, we have identified the geographical distribution of GHG emission impacts associated with SGIP projects throughout California summed by zip code in Figure 6-7.

In Figure 6-7, green dots represent a net decrease in GHG emissions for SGIP projects aggregated at any given zip code. The red dots represent a net increase in GHG emissions for SGIP projects aggregated at any given zip code. The size of the dot is related to the magnitude of the impacts. SGIP projects, and by association their GHG impacts, are distributed primarily near major metropolitan areas. Note that although directed biogas projects are shown on this figure, by the nature of their operation, their GHG reductions actually occur somewhere other than the location of the DG project.

**Figure 6-7: Geographic Distribution of SGIP GHG Emission Impacts (Includes Tons of CO<sub>2</sub> and CO<sub>2</sub>Eq)**



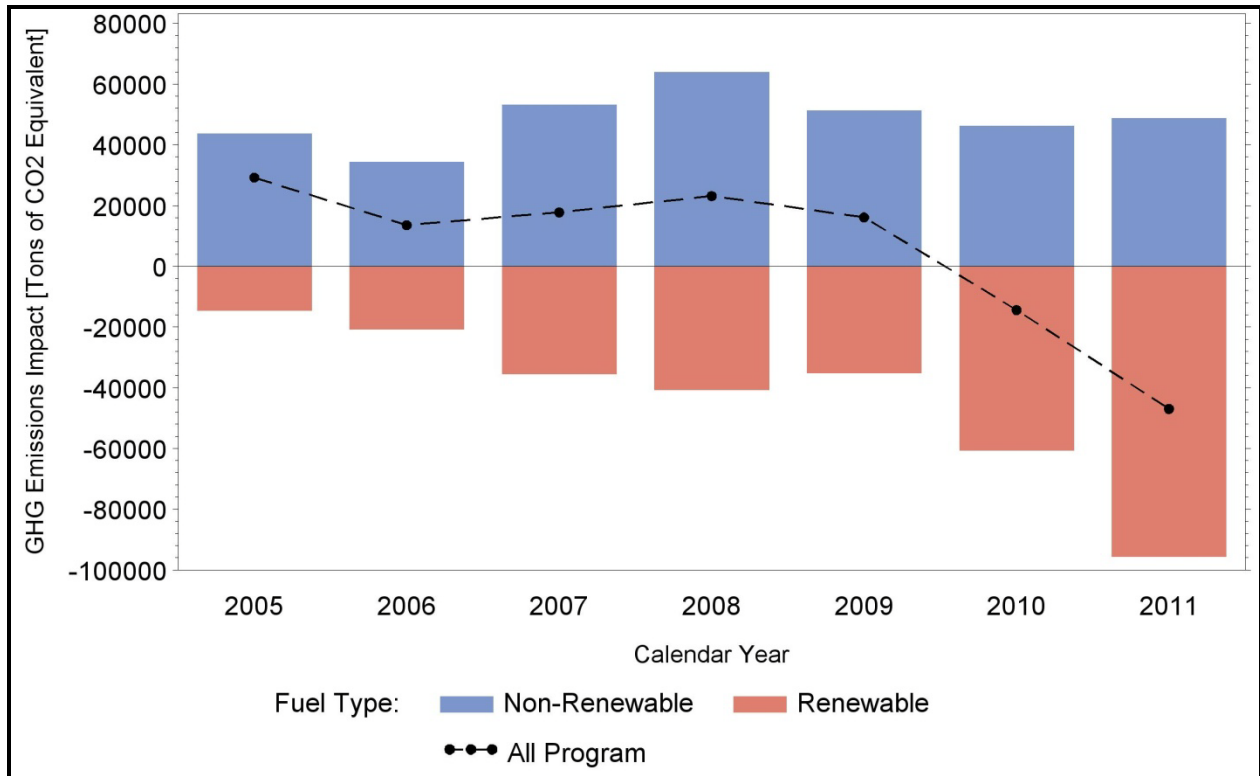
GIS data courtesy of the California Energy Commission.

### 6.3 Trends in Greenhouse Gas Emissions Impacts

The methodology used to calculate PY11 GHG impacts can be applied retroactively to previous years to determine trends in GHG emissions impacts. It is important to note that while at one point photovoltaic (PV) systems were eligible for incentives by the SGIP; the trends discussed in

this section exclude PV altogether. Furthermore, as with all PY11 impacts, this trend analysis excludes the effects of wind projects due to a lack of metered performance data. Figure 6-8 shows trends in GHG impacts since 2005 in metric tons of CO<sub>2</sub> per year.

**Figure 6-8: Trends in CO<sub>2</sub> (and CO<sub>2</sub>Eq) Emission Impacts by Fuel Type**



The dashed line in Figure 6-8 shows GHG impacts over time for the entire SGIP fleet. Separate bars are drawn for renewable and non-renewable projects. The dashed line above the GHG neutral line (zero) shows that the SGIP was a net GHG emitter through 2009. Non-renewable projects (blue bars) have shown a relatively flat trend in GHG impacts, while renewable project GHG emissions impacts (red bars) have trended further and further toward net GHG reductions (more negative). This decrease in GHG impacts from renewable projects has helped the overall program become a net GHG reducer.

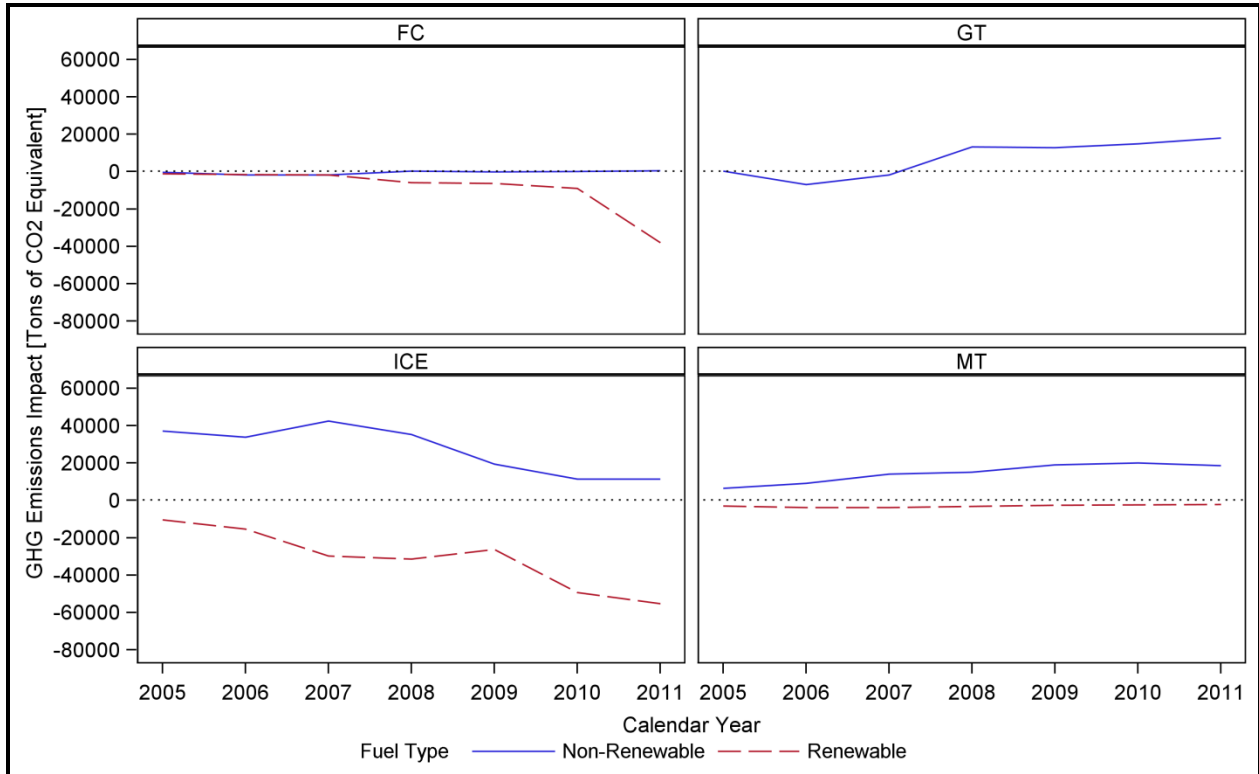
After carefully reviewing Figure 6-8, two important questions must be asked:

1. Why have non-renewable GHG impacts remained relatively flat, despite the continuous addition of new systems?
2. What are the key factors causing the significant decrease in GHG impacts for renewable projects?



To start answering these questions we can further break down the GHG trends by technology and fuel type as shown in Figure 6-9.

**Figure 6-9: Trends in CO<sub>2</sub> (and CO<sub>2</sub>Eq) Emission Impacts by Technology and Fuel Type**

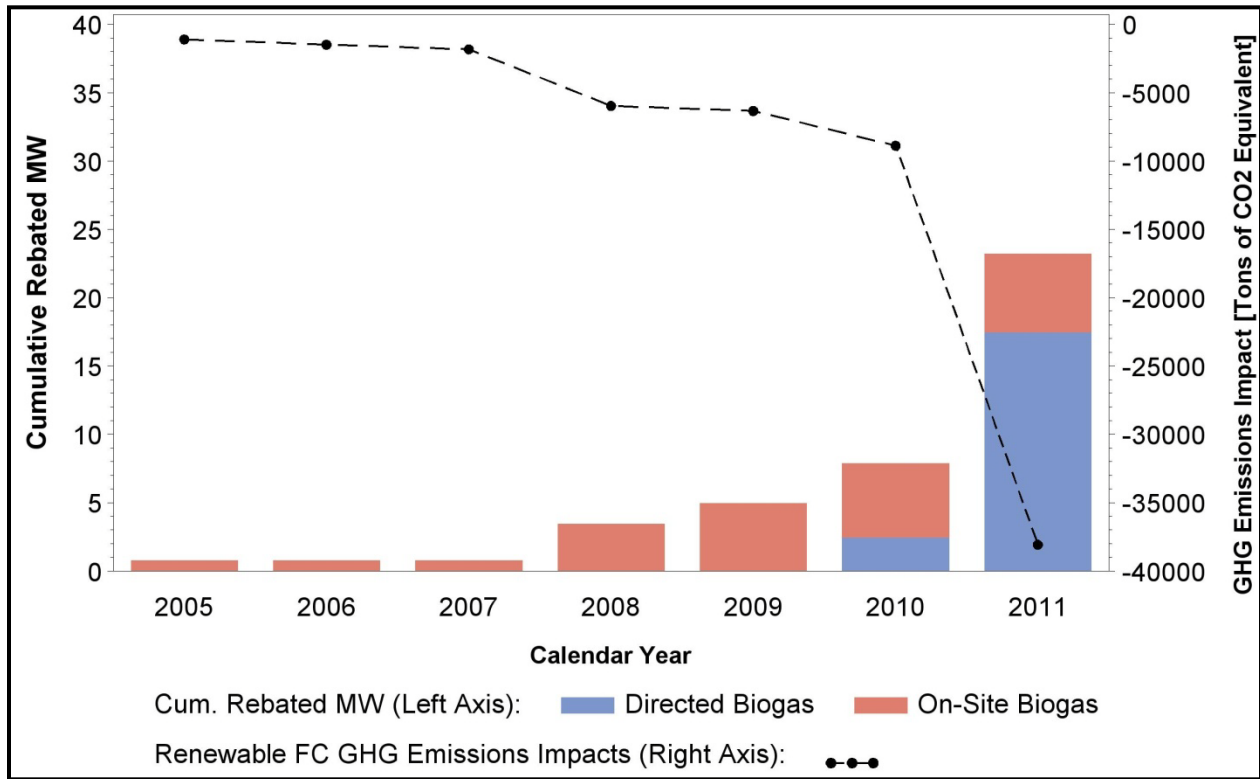


Trends in GHG impacts vary by technology and fuel type. Each panel in Figure 6-9 shows GHG emissions impacts for a specific technology. Each panel contains a solid blue line representing GHG impacts of non-renewable systems, and a dashed red line representing impacts of renewable systems. Looking first at non-renewable systems (blue lines), almost all technologies have operated at or above zero since 2005, which indicates continuous increases in GHG emission impacts. The only exception is gas turbine technology, which showed slightly negative (i.e., decreasing) GHG impacts between 2006 and 2007.

Still looking at Figure 6-9, dashed red lines in each quadrant represent impacts of renewable fueled projects for each technology. All renewable fueled technologies inherently reduce GHG emissions and are shown by dashed red-lines appearing below zero (net GHG).

Taking a closer look at renewable fuel cells, Figure 6-10 shows renewable fuel cell annual GHG impacts over time (same as the dashed red line on the top left panel of Figure 6-9) and cumulative rebated renewable fuel cell capacity.

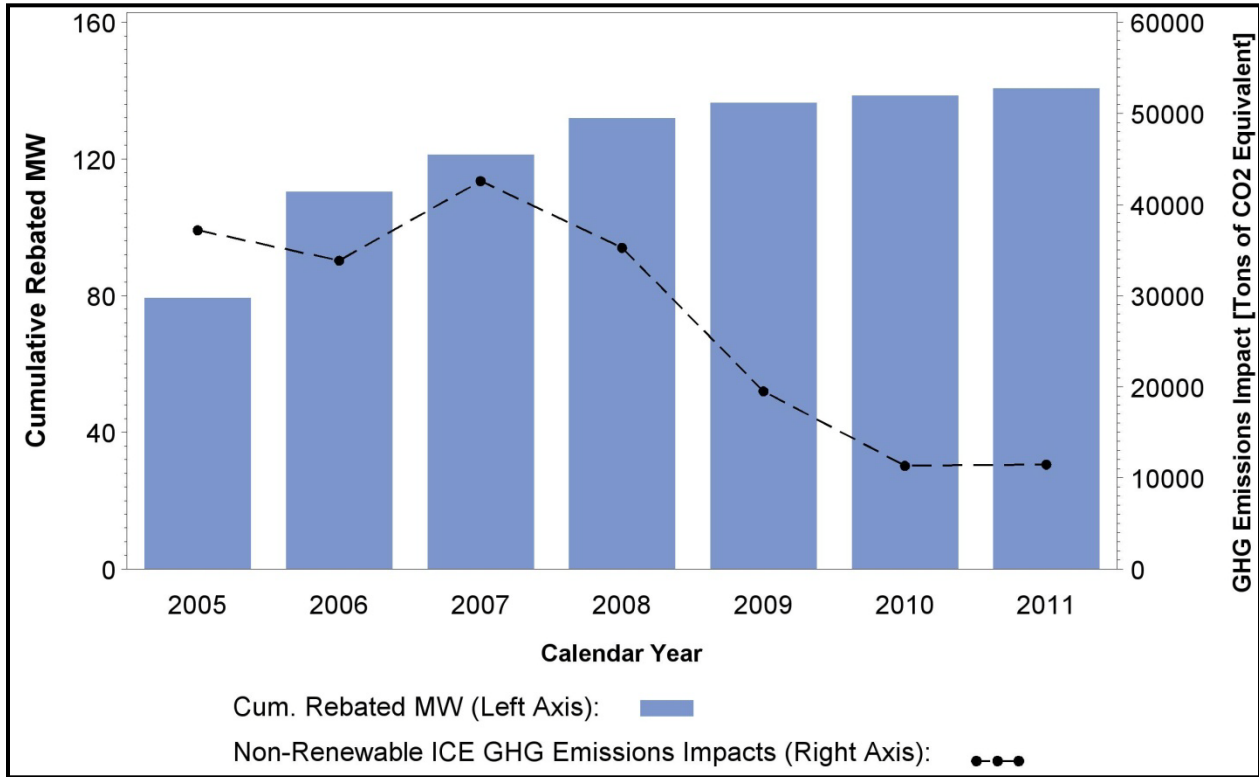
**Figure 6-10: Trends in CO<sub>2</sub> (and CO<sub>2</sub>Eq) Emissions Impacts and Rebated Capacity for Renewable Fuel Cells**



The bars in Figure 6-10 represent the ongoing cumulative capacity of renewable fuel cells rebated by the SGIP. On-site biogas fuel cells are shown in red and directed biogas fuel cells are shown in blue. There is an almost direct correlation between the renewable fuel cell installed capacity and the renewable fuel cell GHG impacts. The sharp decline in GHG impacts observed in 2011 is more than likely due to the large amount of directed biogas fuel cells installed that year. As the amount of net-GHG reducing technologies increases, the overall GHG impacts decrease.

Looking back at Figure 6-9, we see another interesting trend in non-renewable IC engine GHG emissions impacts (the blue line in the bottom left quadrant). Over time, GHG impacts from non-renewable IC engines have decreased in magnitude, trending toward net zero GHG emissions. Figure 6-11 shows the trends in GHG impacts from non-renewable IC engines and the corresponding cumulative rebated capacity per year.

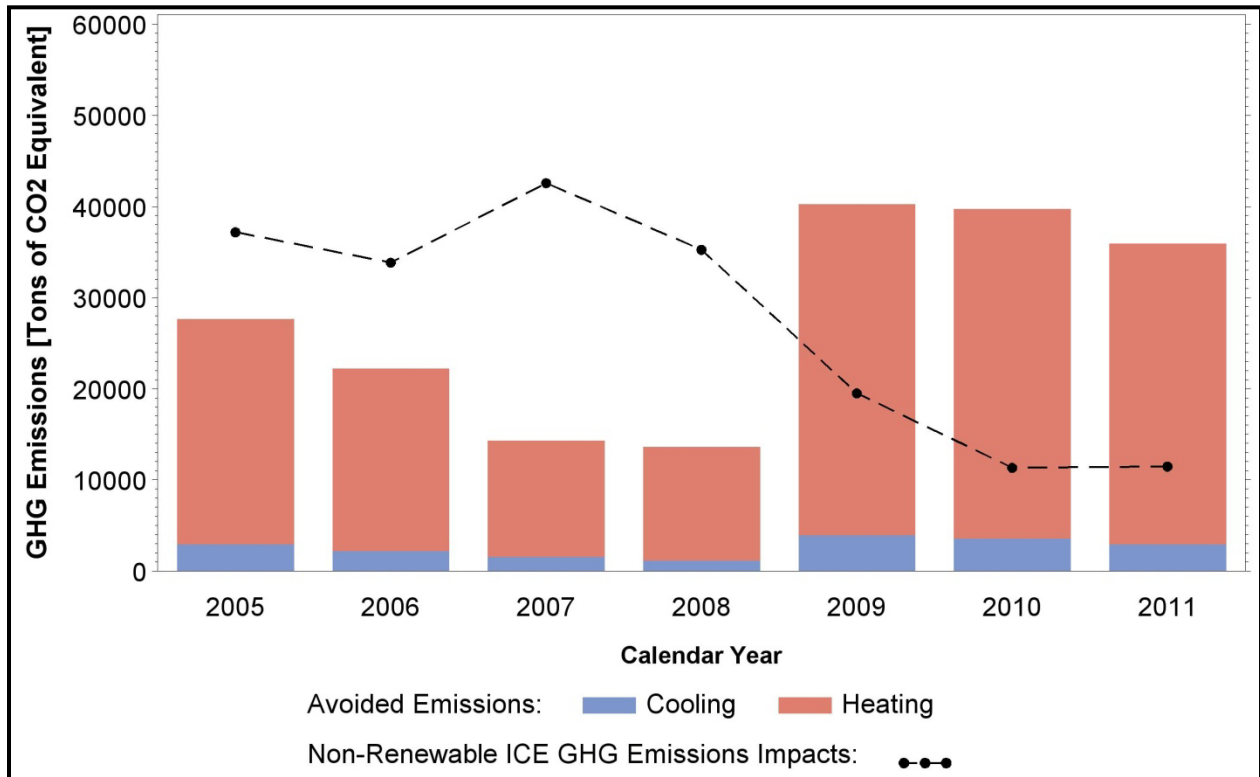
**Figure 6-11: Trends in CO<sub>2</sub> (and CO<sub>2</sub>Eq) Emission Impacts and Rebated Capacity for Non-renewable IC Engines**



GHG emissions rates from non-renewable IC engines in the SGIP have been positive since 2005, meaning that they were net GHG emitters. One would expect that as more (net emitting) IC engines come online; the total emissions from non-renewable IC engines would increase. However, we see in Figure 6-11 that as more non-renewable IC engines are added (blue bars, left axis), the net GHG impacts from non-renewable IC engines (dashed line, right axis) decrease. A variety of factors could contribute to this decrease including decommissioned systems, systems that are powered off, electrical efficiencies, and heat recovery rates.

Figure 6-12 takes a closer look at the relationship between avoided emissions from heating/cooling services and total GHG impacts from non-renewable IC engines.

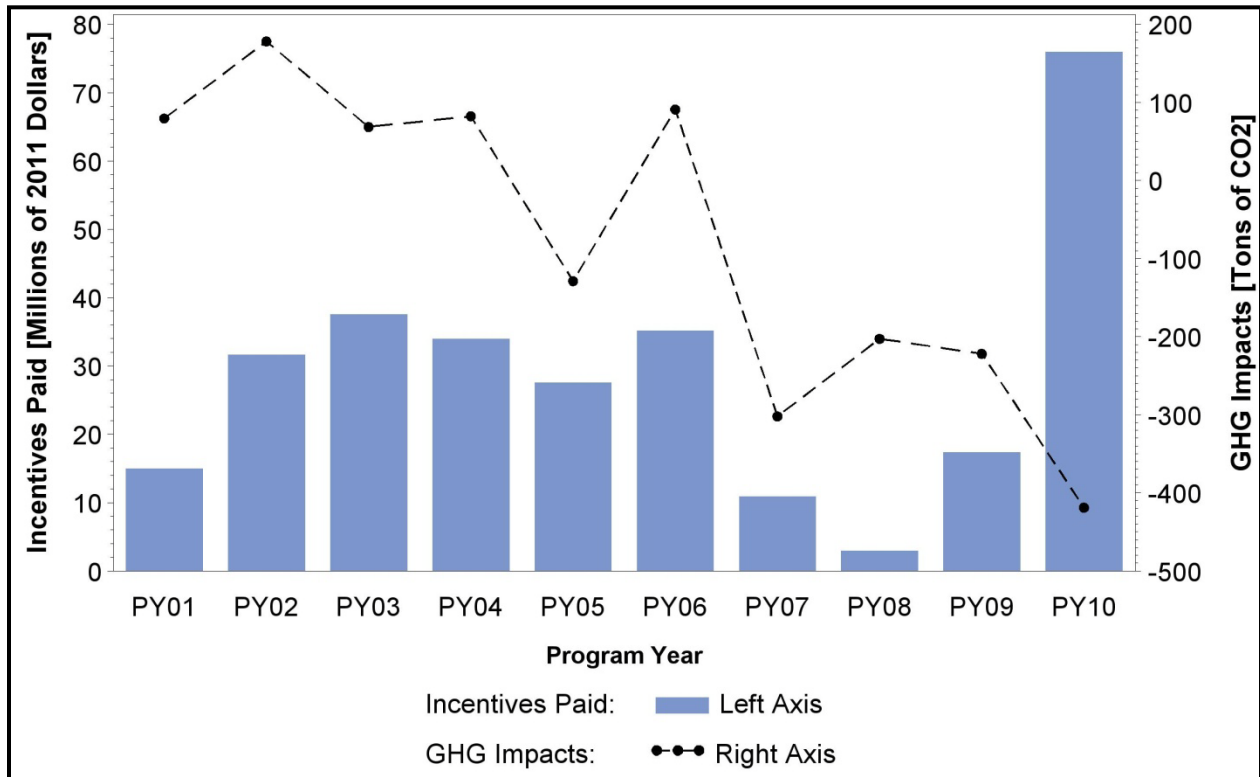
**Figure 6-12: Trends in CO<sub>2</sub> (and CO<sub>2</sub>Eq) Emission Impacts and Avoided Heating/Cooling Emissions for Non-renewable IC Engines**



In Figure 6-12, the dashed line shows total GHG impacts from non-renewable IC engines (as does Figure 6-11). The red bars show heating GHG emissions avoided by non-renewable IC engines displacing natural gas boilers. Similarly, the blue bars show cooling GHG emissions avoided by non-renewable IC engines displacing electric chillers. The red and blue bars combined are a good proxy for the amount of heat recovered by a system. As more heat is recovered, more boiler and chiller operations are offset. In 2009, we see a sharp increase in the amount of avoided GHG from heating services by non-renewable IC engines, which goes a long way toward explaining the sharp decrease in total GHG emissions from non-renewable IC engines. Again, many other factors related to system performance may influence the total GHG emissions, but for non-renewable IC engines, heat recovery appears to be a key factor.

Looking at total incentives paid, Figure 6-13 shows a trend of total incentives paid and GHG impact as a function of program year (PY). The SGIP program year should not be confused with a calendar year. The program year represents when a system applied to the SGIP; not when it entered operations.

**Figure 6-13: Program Trends in CO<sub>2</sub> (and CO<sub>2</sub>Eq) Emission Impacts and Incentives Paid**



The dashed line in Figure 6-13 shows GHG impacts of SGIP projects during their first year of operation as a function of their program year (plotted against the right axis). For example, projects that entered the program in PY07 had a net impact of approximately -300 (reduction) tons of CO<sub>2</sub> per year. The downward trend in GHG impacts indicates that newer projects in the SGIP are generally more effective at reducing GHG emissions. The blue bars (plotted against the left axis) show the total incentives paid each program year. Overall, technologies rebated in later years tend to have lesser impacts (more reduction) on GHG – however there is no clear connection visible between incentives paid and GHG emission impacts.

## 6.4 Key Observations

A few key observations are evident from the GHG analysis for SGIP projects in 2011:

- At the end of calendar year 2011, the SGIP reduced GHG emissions by over 46,000 metric tons per year (as CO<sub>2</sub> equivalent).
- Non-renewable projects increased net GHG emissions by over 48,000 metric tons per year.

- Electric-only fuel cells were the single GHG net-reducing non-renewable technology, but their impacts were not large enough to offset emissions from other non-renewable systems.
- Renewable-fueled projects that would have flared their fuel in the absence of the SGIP were the greatest source of GHG emission reductions, having reduced GHG emissions by over 65,000 metric tons per year.
- Renewable-fueled IC engine projects that otherwise would have emitted methane directly into the atmosphere (venting), represented the single most effective source of GHG reductions and reduced GHG emissions at a rate of 4.5 tons of CO<sub>2</sub> per MWh.
- There are three clear paths to GHG emission reductions by SGIP projects:
  - For electric-only technologies, electrical efficiencies high enough to exceed the efficiencies of off-peak grid generation.
  - High heat recovery rates and modest electrical conversion efficiencies, which lead to high overall combined heat and power system efficiencies.
  - Renewable-fueled systems that offset the flaring or venting of methane.

# Appendix A

## Energy and Demand Impacts and Trends

---

### A.1 Overview

This appendix provides summaries of observed energy and demand impacts and their trends for the eleventh-year impact evaluation. It describes demand impacts and capacity factors (CFs) for the 2011 CAISO peak day as well as for individual investor-owned utility (IOU) 2011 peak days. This appendix is divided into four sections. The first section presents 2011 impacts for the program overall. The second and third sections present 2011 impacts for renewable and non-renewable technologies, respectively. The fourth section provides summaries of annual trends. Below is a brief outline of these sections.

#### **A.1.1 Appendix A Energy and Demand Impacts and Trends**

- A.1 Overview
  - 2011 Annual Energy
  - 2011 Peak Demand Impacts
  - 2011 Capacity Factors
- A.2 Renewable Fuel Projects
  - Renewable Fuel Cells
  - Renewable Internal Combustion Engines and Microturbines
- A.3 Non-Renewable Fuel Projects
  - Non-renewable Fuel Cells
  - Non-renewable Gas Turbines, Internal Combustion Engines, and Microturbines
- A.4 Annual Trends
  - Growth in Capacity and Annual Impacts by Year
  - Annual Capacity Factor and Off-line Trends with Age
  - CAISO Peak Hour Capacity Factor and Off-line Trends with Age
  - 2011 Decommissioned and Off-line Capacities by Project Vintage

The sequence of each section is as follows:

1. 2011 Annual Energy Annual Electric Energy Totals by PA Quarterly Electric Energy Totals
2. 2011 Peak Demand CAISO Peak Hour Demand Impacts IOU Peak Hours Demand Impacts
3. 2011 Capacity Factors Annual Capacity Factors Annual Capacity Factors by Technology Annual Capacity Factors by Technology and PA Monthly Capacity Factors by Technology CAISO Peak Day Capacity Factors by Technology Electric Utility Peak Day Capacity Factors by Technology
4. Annual Trends Growth in Capacity and Impacts by Year Annual Capacity Factor and Off-line Trends with Age CAISO Peak Hour Capacity Factor and Off-line Trends with Age 2011 Decommissioned and Off-line Capacities by Project Vintage

Reporting of overall program results and of annual energy by technologies includes a distinction between metered and estimated values. Metered values have very little uncertainty, with most meters having accuracies within one percent. The uncertainty of estimated values is greater and is the primary determinant of the margin of error of results.

Results presented for the peak days of the three individual electric utilities do not strictly include all projects or only projects administered by the Program Administrator (PA) associated with the electric utility. About half of the projects administered by SCG feed SCE's distribution grid, while a small number feed PG&E or SDG&E; the remainder feed small electric utilities. A small number of PG&E's projects feed directly into distribution grids for small electric utilities.

This appendix summarizes relative performance of groups of projects in terms of their weighted average CFs for specific time periods. These measures describe electric net generation output relative to a unit of project-rebated capacity. For example, an hourly CF of 0.7 during the CAISO system peak hour indicates that 0.7 kW of net electrical output was produced for every kW of related project-rebated capacity.

### **A.1.2 2011 Annual Energy**

Table A-1 presents annual total net electrical output in GWh for the program and for each PA. It also shows subtotals for each PA and technology. This table also shows subtotals by basis (metered, and estimated), indicating respectively the subtotal physically metered at the many SGIP sites and the subtotal estimated where metered electrical energy data were not available. Later tables in this appendix differentiate between non-renewable and renewable fuel categories.



**Table A-1: Annual Electric Energy Totals by Technology and PA**

Technology	Basis	PG&E	SCE	SCG	CCSE	Total
		(GWh)	(GWh)	(GWh)	(GWh)	(GWh)
FC	Total*	98	27	40	12	177
	M*	70	10	20	8	107
	E*	29	17 †	20 †	4 †	70
GT	Total*	19 †	0	92	76	187
	M*	0	0	83	76	160
	E*	19 †	0	8 <sup>a</sup>	0	28 †
ICE	Total*	143	51	112	13	319
	M*	60	24	66	13	163
	E*	83	27 †	46 †	0 <sup>a</sup>	156
MT	Total*	44	10	19	3	76
	M*	26	6	16	3	50
	E*	18 †	4 †	3 †	0 <sup>a</sup>	26 †
Total		305	87	263	104	760
	M*	155	39	185	100	480
	E*	149	48	78	4	279

\* For all but last row, <sup>a</sup> indicates confidence is less than 70/30. † indicates confidence is better than 70/30. No symbol indicates confidence is better than 90/10.

Table A-2 presents quarterly total net electrical output in GWh for the program. It also shows subtotals for each technology and fuel category, non-renewable versus renewable. Additionally, it shows subtotals by basis (metered and estimated), indicating respectively the subtotal physically metered at the many SGIP sites and the subtotal estimated where metered electrical energy data were not available.

**Table A-2: 2011 Quarterly Electric Energy Totals**

Technology	Fuel	Basis	Q1-2011	Q2-2011	Q3-2011	Q4-2011	Total
			(GWh)	(GWh)	(GWh)	(GWh)	(GWh)
FC	N	Total*	14	17	19	18	68
		M*	7	9	11	10	36
		E*	7	8	9	8	31
FC	R	Total*	21	26	31	31	110
		M*	12	16	19	24	71
		E*	10	10	12	7	39
GT	N	Total*	44	47	47	50	187
		M*	39	42	41	38	160
		E*	5	5	5	12	28 †
ICE	N	Total*	57	61	78	62	257
		M*	23	30	41	32	126
		E*	34	30	37	30	131
ICE	R	Total*	11	16	18	18	62
		M*	7	9	10	10	37
		E*	4	6	7	8	25 †
MT	N	Total*	14	19	18	20	71
		M*	8	13	12	14	48
		E*	5	6	6	6	23 †
MT	R	Total*	1.2	0.9	1.4	1.4	5
		M*	0.6	0.6	0.8	0.8	3
		E*	0.6	0.3	0.7	0.6	2 †
Total	N	Total	128	143	162	150	583
		M	77	94	105	94	370
		E	52	49	57	56	213
Total	R	Total	33	43	50	51	177
		M	20	26	30	35	111
		E	14	17	20	16	66
Total		Total	161	186	211	201	760
		M	96	120	135	129	480
		E	65	66	76	72	279

\* In rightmost column only and except for last row, <sup>a</sup> indicates confidence is less than 70/30. † indicates confidence is better than 70/30. No symbol indicates confidence is better than 90/10.

### A.1.3 2011 Peak Demand Impacts

Table A-3 presents total net electrical output in kW for the program during the CAISO peak hour of 4:00 to 5:00 P.M. (PDT) on September 11, 2011. The table also shows subtotals of output, counts of projects, and total project capacity in kW for each technology and basis. The two bases, metered and estimated, indicate respectively the subtotal physically metered at the many SGIP sites and the subtotal estimated where metered electrical energy data were not available. Later tables in this appendix differentiate peak demand impacts between non-renewable and renewable fuel categories.

**Table A-3: 2011 CAISO Peak Hour Demand Impacts**

CAISO Peak (MW)	Date	Hour (PDT hour beginning)			
45,569	7-Sep-11	4 PM			
Technology	Basis	Project Count (n)	Capacity (MW)	Impact (MW)	Hourly Capacity Factor
FC	Total*	113	32	23	0.70
	M*	89	19	14	0.72
	E*	24	13	9	0.68 †
GT	Total*	8	26	21	0.83
	M*	6	23	19	0.83
	E*	2	3	2	0.85 <sup>a</sup>
ICE	Total*	254	156	53	0.34
	M*	158	99	28	0.28
	E*	96	57	25	0.44 †
MT	Total*	140	25	9	0.35
	M*	96	19	6	0.31
	E*	44	6	3	0.46 †
	Total	515	238	105	0.44
	M	349	160	67	0.42
	E	166	78	39	0.49

\* In column with hourly CF only, <sup>a</sup> indicates confidence is less than 70/30. † indicates confidence is better than 70/30. No symbol indicates confidence is better than 90/10.

Figure A-1 plots profiles of hourly total net electrical output in kW for each technology from morning to early evening during the day of the CAISO annual peak hour, September 7, 2011. The chart also shows the profile of the hourly CAISO loads in MW using the vertical axis on the right side of the chart. The preceding table shows the values of net output for each technology during the peak hour. Again, later tables and charts in this appendix differentiate by non-renewable and renewable fuel categories.

**Figure A-1: 2011 CAISO Peak Day Output by Technology**

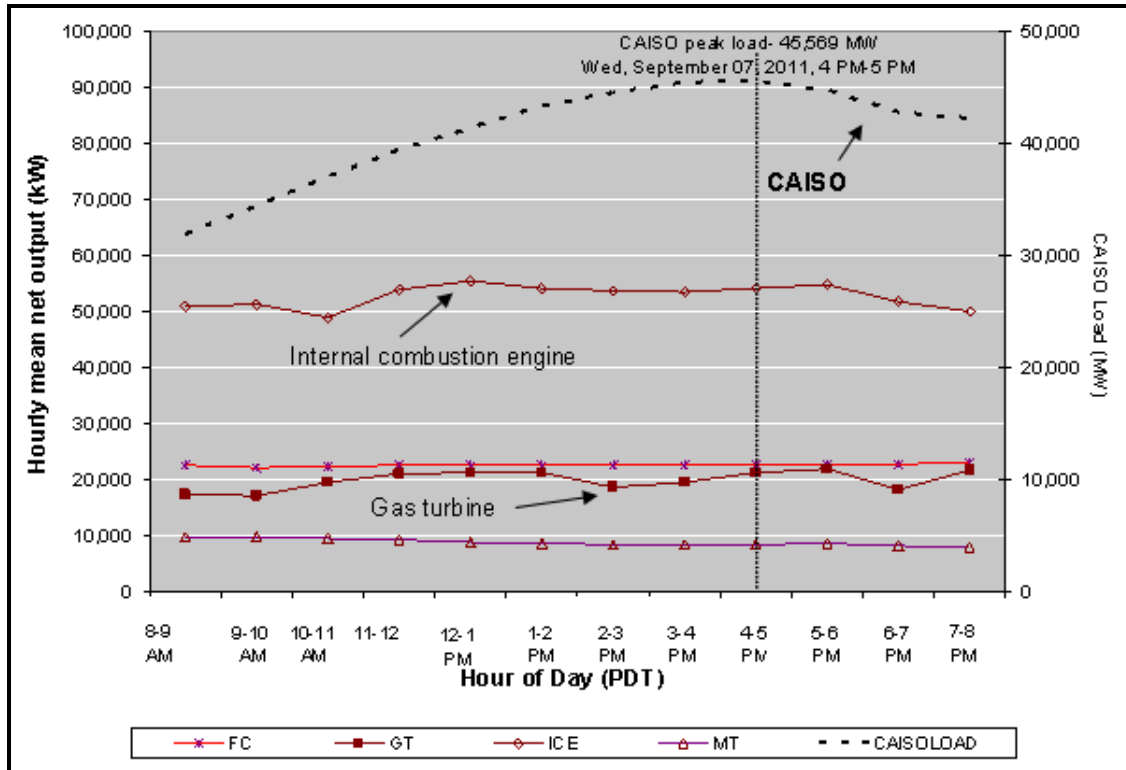


Table A-4, Table A-5, and Table A-6 list for each electric utility the hourly total net electrical output in kW during the annual peak hour from 4:00 to 5:00 P.M. (PDT) on September 7, 2011. The tables also list the number of program projects, their combined capacities, and their hourly CFs. The last three rows of each table summarize the results across all technologies and fuels. Results presented for the three individual electric utilities for the CAISO peak hour do not strictly include all projects or only projects administered by the PA associated with the electric utility. About half of projects administered by SCG feed SCE’s distribution grid, while a small number feed PG&E or SDG&E; the remainder feed small electric utilities. A small number of PG&E’s projects feed directly into distribution grids for small electric utilities.

**Table A-4: 2011 CAISO Peak Hour Output by Technology, Fuel, and Basis—PG&E**

Type	Fuel	Basis	Project Count (n)	Capacity (MW)	Impact (MW)	Hourly Capacity Factor (kWh/kWh)
FC	N	Total*	31	6.6	3.6	0.55 †
		M*	24	3.8	2.1	0.54
		E*	7	2.8	1.6	0.56 †
FC	R	Total*	20	7.7	7.2	0.93 †
		M*	19	7.1	6.6	0.93
		E*	1	0.6	0.6	0.93 <sup>a</sup>
GT	N	Total*	3	4.0	2.2	0.56 <sup>a</sup>
		M*	1	1.4	0.0	0.00
		E*	2	2.6	2.2	0.85 <sup>a</sup>
ICE	N	Total*	102	57.0	19.6	0.34 †
		M*	55	31.4	8.2	0.26
		E*	47	25.6	11.4	0.45 †
ICE	R	Total*	15	8.1	5.5	0.69 †
		M*	10	5.7	3.4	0.61
		E*	5	2.4	2.1	0.88 <sup>a</sup>
MT	N	Total*	45	8.7	4.8	0.55 †
		M*	25	6.3	3.4	0.54
		E*	20	2.4	1.4	0.59 <sup>a</sup>
MT	R	Total*	13	2.0	0.3	0.13 †
		M*	9	1.3	0.1	0.10
		E*	4	0.6	0.1	0.19 <sup>a</sup>
		Total	229	94.1	43.3	0.46
		M	143	57.0	23.8	0.42
		E	86	37.1	19.5	0.53

\* In column with hourly CF only, excluding grand total rows at bottom, <sup>a</sup> indicates confidence is less than 70/30. † indicates confidence is better than 70/30. No symbol indicates confidence is better than 90/10.

**Table A-5: 2011 CAISO Peak Hour Output by Technology, Fuel, and Basis—SCE**

Type	Fuel	Basis	Project Count (n)	Capacity (MW)	Impact (MW)	Hourly Capacity Factor (kWh/kWh)
FC	N	Total*	12	1.3	0.6	0.46 †
	N	M*	9	0.8	0.3	0.39
	N	E*	3	0.5	0.3	0.59 †
FC	R	Total*	12	6.2	4.2	0.68 <sup>a</sup>
	R	M*	6	2.2	1.3	0.60
	R	E*	6	4.0	2.9	0.72 <sup>a</sup>
GT	N	Total*	3	12.6	10.3	0.82
	N	M*	3	12.6	10.3	0.82
	N	E*	0	0.0	0.0	
ICE	N	Total*	97	67.7	22.3	0.33 †
	N	M*	64	45.0	13.4	0.30
	N	E*	33	22.7	8.8	0.39 <sup>a</sup>
ICE	R	Total*	8	5.8	1.0	0.17 <sup>a</sup>
	R	M*	4	3.4	0.0	0.00
	R	E*	4	2.4	1.0	0.41 <sup>a</sup>
MT	N	Total*	52	8.9	2.4	0.27 †
	N	M*	37	7.3	1.8	0.25
	N	E*	15	1.7	0.6	0.36 <sup>a</sup>
MT	R	Total*	4	1.0	0.0	0.02 †
	R	M*	3	1.0	0.0	0.00
	R	E*	1	0.1	0.0	0.30 <sup>a</sup>
		Total	188	103.6	40.8	0.39
		M	126	72.2	27.2	0.38
		E	62	31.3	13.6	0.43

\* In column with hourly CF only, excluding grand total rows at bottom, <sup>a</sup> indicates confidence is less than 70/30. † indicates confidence is better than 70/30. No symbol indicates confidence is better than 90/10.

**Table A-6: 2011 CAISO Peak Hour Output by Technology, Fuel, and Basis—SDG&E**

Type	Fuel	Basis	Project Count (n)	Capacity (MW)	Impact (MW)	Hourly Capacity Factor (kWh/kWh)
FC	N	Total*	5	2.3	0.8	0.34 †
	N	M*	5	2.3	0.8	0.34
	N	E*	0	0.0	0.0	
FC	R	Total*	2	0.8	0.6	0.76
	R	M*	0	0.0	0.0	
	R	E*	2	0.8	0.6	0.76
GT	N	Total*	2	9.1	8.8	0.96
	N	M*	2	9.1	8.8	0.96
	N	E*	0	0.0	0.0	
ICE	N	Total*	21	12.1	2.2	0.18
	N	M*	21	12.1	2.2	0.18
	N	E*	0	0.0	0.0	
ICE	R	Total*	1	0.6	0.5	0.94
	R	M*	1	0.6	0.5	0.94
	R	E*	0	0.0	0.0	
MT	N	Total*	13	1.1	0.3	0.23
	N	M*	12	1.1	0.3	0.23
	N	E*	1	0.1	0.0	0.23 <sup>a</sup>
MT	R	Total*	4	0.8	0.0	0.05
	R	M*	4	0.8	0.0	0.05
	R	E*	0	0.0	0.0	
		Total	48	26.8	13.2	0.49
		M	45	25.9	12.5	0.48
		E	3	0.9	0.6	0.72

\* In column with hourly CF only, excluding grand total rows at bottom, <sup>a</sup> indicates confidence is less than 70/30. † indicates confidence is better than 70/30. No symbol indicates confidence is better than 90/10.

Figure A-2, Figure A-3, and Figure A-4 plot for each electric utility profiles of hourly total net electrical output in kW for each technology from morning to early evening during the day of the annual peak hour, September 7, 2011. The charts also show the profile of the hourly CAISO loads in MW using the vertical axis on the right side of the chart. The preceding tables list the values associated with these charts for the peak hour. Results presented for the three individual electric utilities on the CAISO peak day do not strictly include all projects or only projects administered by the PA associated with the electric utility. About half of projects administered by SCG feed SCE’s distribution grid, while a small number feed PG&E or SDG&E; the remainder feed small electric utilities. A small number of PG&E’s projects feed directly into distribution grids for small electric utilities.

**Figure A-2: 2011 CAISO Peak Day Output by Technology, and Fuel—PG&E**

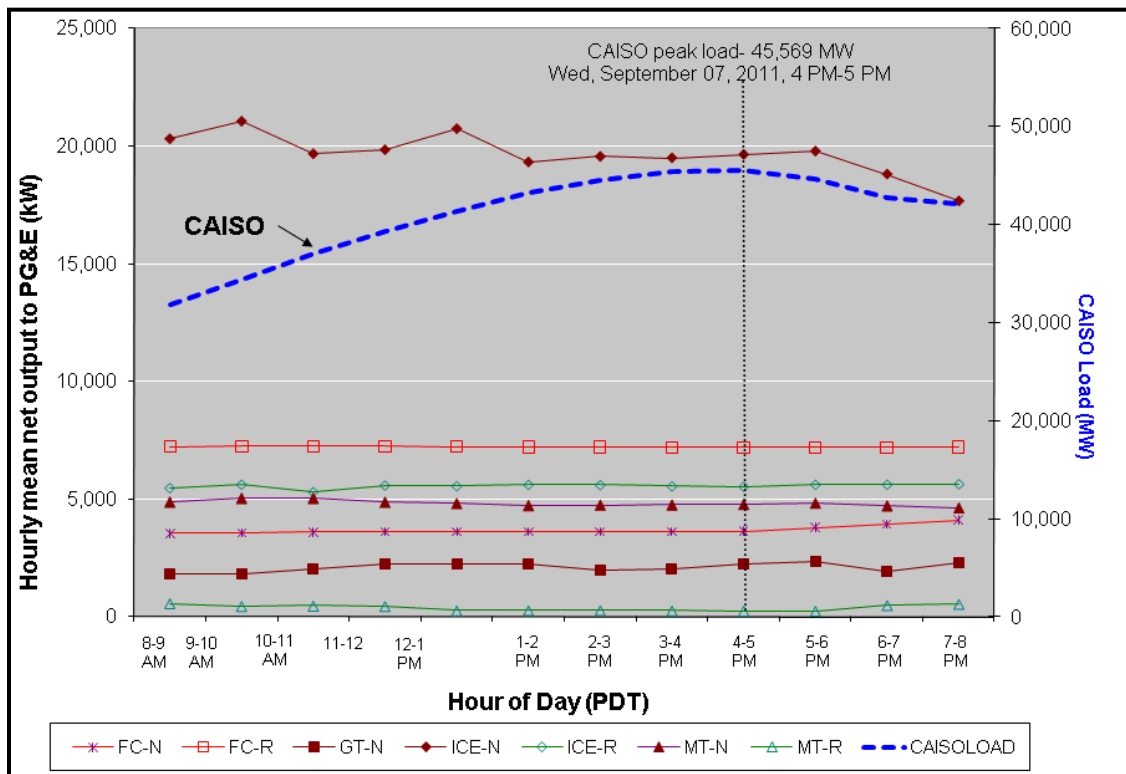




Figure A-3: 2011 CAISO Peak Day Output by Technology, and Fuel—SCE

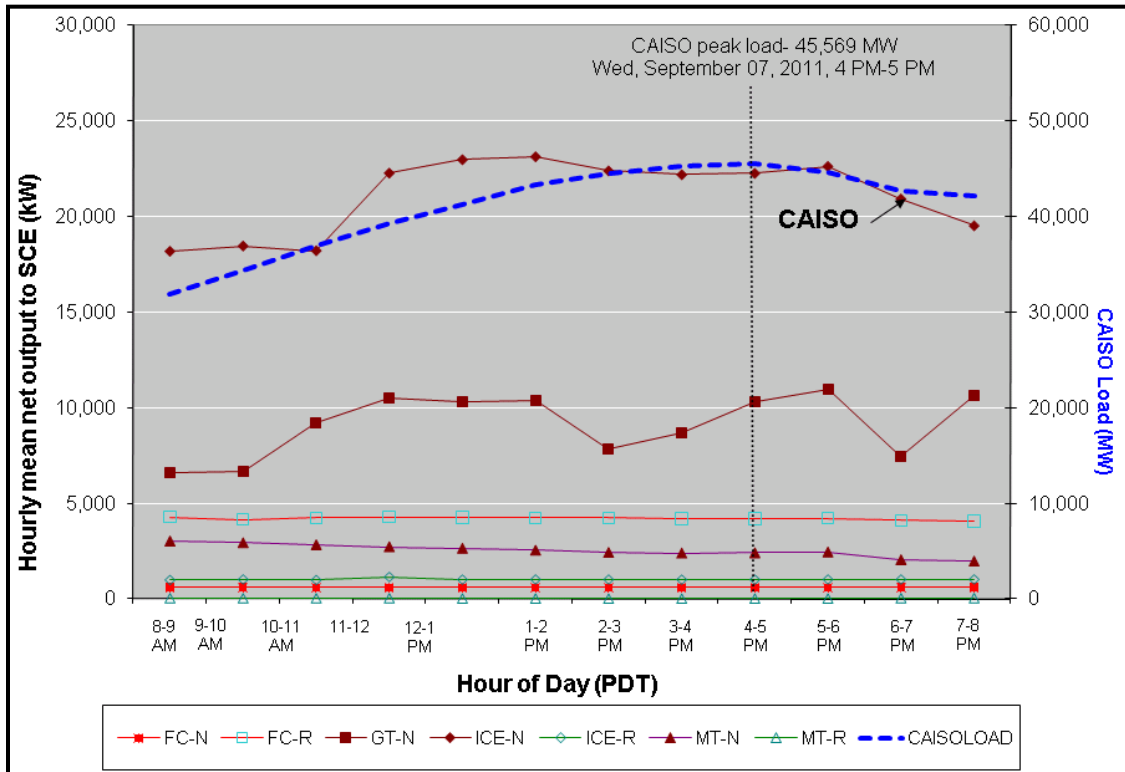


Figure A-4: 2011 CAISO Peak Day Output by Technology, and Fuel—SDG&E

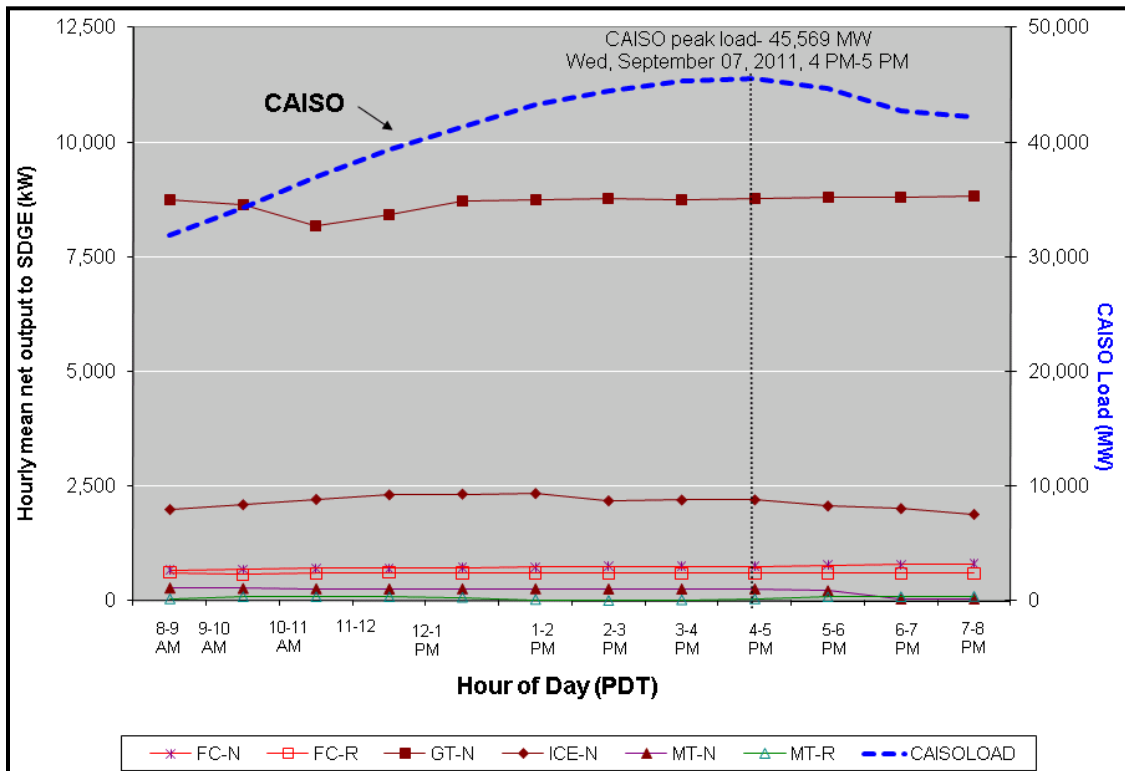


Table A-7, Table A-8, and Table A-9 present the total net electrical output in kW during the respective peak hours of the three large, investor-owned electric utilities. Preceding each of these are small tables listing the date, hour, and load of the utility’s peak hour day. The tables also show for each technology and basis the subtotals of output, counts of projects, and total project capacity in kW. The two bases, metered and estimated, indicate respectively the subtotal physically metered at the many SGIP sites and the subtotal estimated where metered electrical energy data were not available. Later tables in this appendix differentiate electric utility peak demand impacts by between non-renewable and renewable fuel categories.

Results presented for the peak days of the three individual electric utilities do not strictly include all projects or only projects administered by the PA associated with the electric utility. About half of the projects administered by SCG feed SCE’s distribution grid, while a small number feed PG&E or SDG&E; the remainder feed small electric utilities. A small number of PG&E’s projects feed directly into distribution grids for small electric utilities.

**Table A-7: 2011 IOU Peak Hours Demand Impacts—PG&E**

<b>Elec PA</b>	<b>Peak (MW)</b>	<b>Date</b>	<b>Hour (PDT)</b>			
<b>PG&amp;E</b>	<b>20,604</b>	<b>21-Jun-11</b>	<b>16</b>			
<b>Technology</b>	<b>Basis</b>	<b>Projects (n)</b>	<b>Capacity (MW)</b>	<b>Demand Impact (MW)</b>	<b>Hourly Capacity Factor (MWh/MWh)</b>	
FC	Total	43	13.0	9.2	0.70	
	M	35	9.6	7.1	0.74	
	E	8	3.4	2.0	0.60	
GT	Total	3	4.0	2.4	0.59	
	M	1	1.4	0.0	0.00	
	E	2	2.6	2.4	0.90	
ICE	Total	118	65.2	21.2	0.33	
	M	68	37.5	9.4	0.25	
	E	50	27.7	11.8	0.43	
MT	Total	58	10.7	4.9	0.46	
	M	33	7.5	3.4	0.46	
	E	25	3.1	1.5	0.48	
	Total	222	92.9	37.7	0.41	
	M	137	56.0	19.9	0.36	
	E	85	36.9	17.7	0.48	

**Table A-8: 2011 IOU Peak Hours Demand Impacts—SCE**

<b>Elec PA</b>	<b>Peak (MW)</b>	<b>Date</b>	<b>Hour (PDT)</b>			
SCE	22,107	7-Sep-11	15			
<b>Technology</b>	<b>Basis</b>	<b>Projects (n)</b>	<b>Capacity (MW)</b>	<b>Demand Impact (MW)</b>	<b>Hourly Capacity Factor (MWh/MWh)</b>	
FC	Total	24	7.4	4.8	0.64	
	M	15	3.0	1.6	0.54	
	E	9	4.5	3.2	0.71	
GT	Total	3	12.6	8.7	0.69	
	M	3	12.6	8.7	0.69	
	E	0	0.0	0.0	0.00	
ICE	Total	105	73.6	23.2	0.32	
	M	68	48.4	13.4	0.28	
	E	37	25.1	9.8	0.39	
MT	Total	56	9.9	2.4	0.24	
	M	40	8.2	1.8	0.22	
	E	16	1.7	0.6	0.36	
	Total	188	103.6	39.1	0.38	
	M	126	72.2	25.5	0.35	
	E	62	31.3	13.6	0.43	

**Table A-9: 2011 IOU Peak Hours Demand Impacts—SDG&E**

Elec PA	Peak (MW)	Date	Hour (PDT)
SDG&E	4,355	7-Sep-11	15

Technology	Basis	Projects (n)	Capacity (MW)	Demand Impact (MW)	Hourly Capacity Factor (MWh/MWh)
FC	Total	7	3.1	1.4	0.44
	M	5	2.3	0.8	0.33
	E	2	0.8	0.6	0.76
GT	Total	2	9.1	8.7	0.96
	M	2	9.1	8.7	0.96
	E	0	0.0	0.0	0.00
ICE	Total	22	12.7	2.7	0.21
	M	22	12.7	2.7	0.21
	E	0	0.0	0.0	0.00
MT	Total	17	1.9	0.3	0.15
	M	16	1.8	0.3	0.15
	E	1	0.1	0.0	0.24
	Total	48	26.8	13.1	0.49
	M	45	25.9	12.5	0.48
	E	3	0.9	0.6	0.72

**A.1.4 2011 Capacity Factors**

This section describes weighted average CFs that indicate project performance relative to project-rebated kW for specific time periods. For example, an hourly weighted average CF of 0.7 during the CAISO system peak hour indicates that 0.7 kW of net electrical output was produced for every kW of related project-rebated capacity.

Table A-10 presents annual weighted average CFs for each technology for the year 2011. The table shows the annual weighted average CFs for each technology using all metered and estimated values, and by bases of metered and of estimated. The two bases, metered and estimated, indicate respectively the subtotal physically metered at the many SGIP sites and the subtotal estimated where metered electrical energy data were not available. The distinction by basis indicates simply that different sets of observations were used in the calculations, not that estimated CFs were systematically lower or higher than metered CFs. Again, later tables in this appendix differentiate CFs between non-renewable and renewable fuel categories.

**Table A-10: 2011 Annual Capacity Factors**

Technology	Basis	Annual Capacity Factor* (kWyear/kWyear)
<b>FC</b>	<b>Total</b>	0.68
	M	0.68
	E	0.67
<b>GT</b>	<b>Total</b>	0.83
	M	0.83
	E	0.85 †
<b>ICE</b>	<b>Total</b>	0.23
	M	0.19
	E	0.31
<b>MT</b>	<b>Total</b>	0.35
	M	0.32
	E	0.45 †

\* <sup>a</sup> indicates confidence is less than 70/30.  
 † indicates confidence is better than 70/30.  
 No symbol indicates confidence is better than 90/10.

Table A-11 presents annual weighted average CFs for each technology and PA for the year 2011. These values arise from the combination of all metered and estimated values. Where entries are blank the PA had no projects of the technology type. Later tables in this appendix differentiate CFs between non-renewable and renewable fuel categories.

**Table A-11: 2011 Annual Capacity Factors by Technology and PA**

Technology	Annual Capacity Factor* (kWyear/kWyear)			
	PG&E	SCE	SCG	CCSE
<b>FC</b>	0.73	0.65	0.70	0.44
<b>GT</b>	0.55 †		0.83	0.95
<b>ICE</b>	0.26	0.19	0.24	0.14
<b>MT</b>	0.46	0.21	0.35	0.17

\* <sup>a</sup> indicates confidence is less than 70/30.  
 † indicates confidence is better than 70/30.  
 No symbol indicates confidence is better than 90/10.

Table A-12 presents annual weighted average CFs for the technologies that can be fueled with either non-renewable natural gas or Renewable biogas gas. Where entries are blank the PA had no projects of the technology type. This table allows easy comparison of these technologies by fuel category.

**Table A-12: 2011 Annual Capacity Factors by Technology and Fuel**

Technology	Annual Capacity Factor* (kWyear/kWyear)	
	Non-Renewable	Renewable
FC	0.55	0.80
GT	0.83	
ICE	0.21	0.49
MT	0.39	0.15

\* <sup>a</sup> indicates confidence is less than 70/30.  
 † indicates confidence is better than 70/30.  
 No symbol indicates confidence is better than 90/10.

Figure A-5 plots profiles of weighted mean monthly CFs for each technology. Again, later charts in this appendix differentiate CFs between non-renewable and Renewable fuel categories.

**Figure A-5: 2011 Monthly Capacity Factors by Technology**

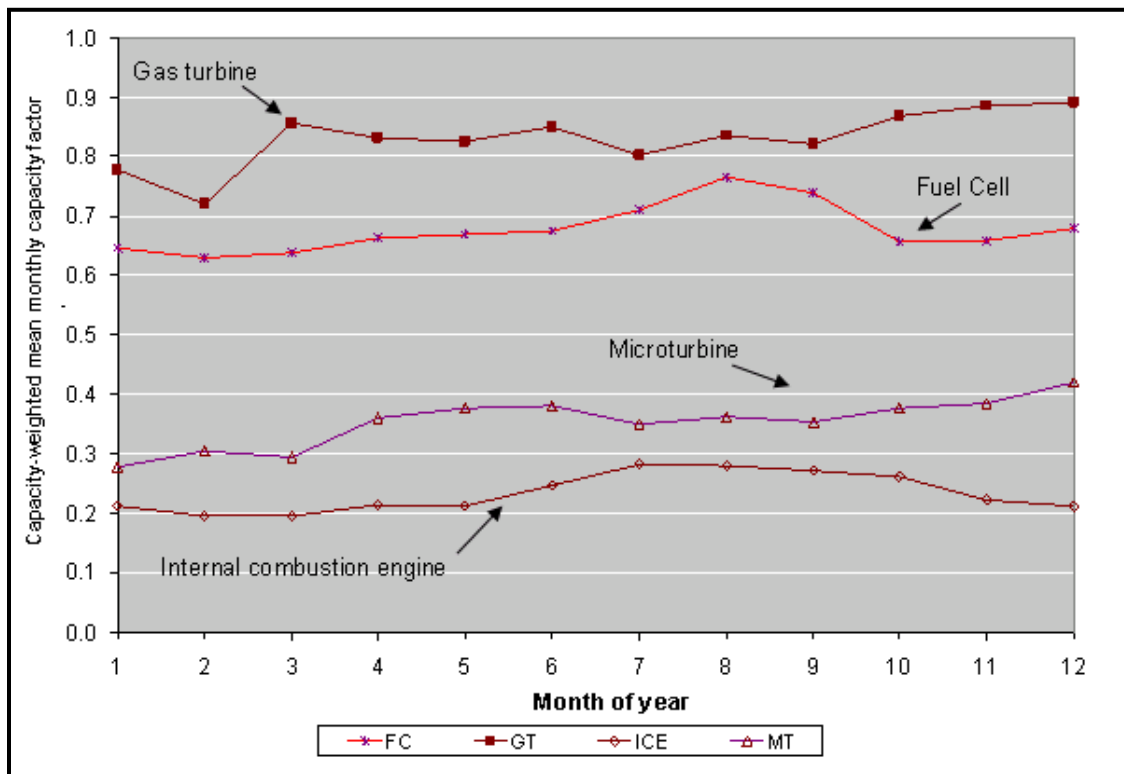


Figure A-6 plots profiles of hourly weighted average CF for each technology from morning to early evening during the day of the annual peak hour, September 7, 2011. The plot also indicates the hour and value of the CAISO peak load. Again, later charts in this appendix differentiate between non-renewable and renewable fuel categories.

**Figure A-6: 2011 CAISO Peak Day Capacity Factors by Technology**

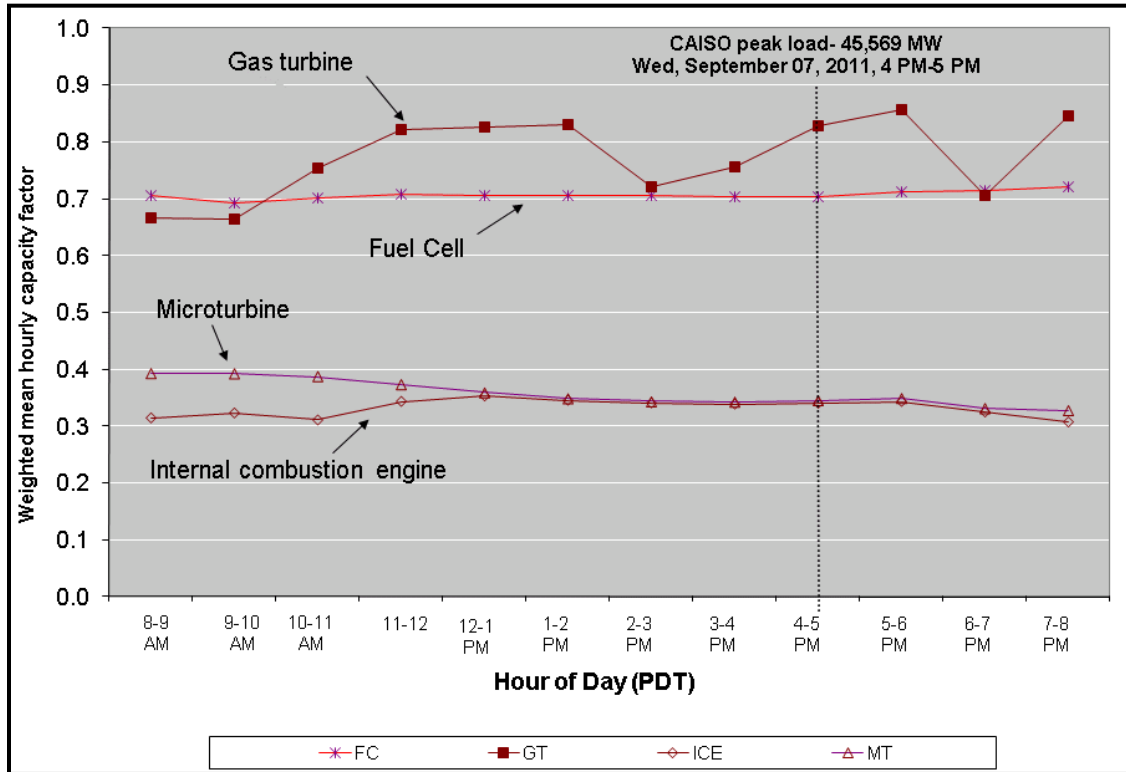


Figure A-7, Figure A-8, and Figure A-9 plot profiles of hourly weighted average CFs by technology for the projects directly feeding the utilities on the dates of their respective annual peak hours. The plots also indicate the date, hour, and value of the peak load for the electric utility. The plots include only those technologies that were served by the electric utility, so not all technologies appear for all electric utilities. In later sections, this appendix describes separately those technologies that can use between non-renewable natural gas versus renewable biogas.

Results presented for the peak days of the three individual electric utilities do not strictly include all projects or only projects administered by the PA associated with the electric utility. About half of all projects administered by SCG feed SCE’s distribution grid, while a small number feed PG&E or SDG&E; the remainder feed small electric utilities. A small number of PG&E’s projects feed directly into distribution grids for small electric utilities.

Figure A-7: 2011 IOU Peak Day Capacity Factors by Technology—PG&E

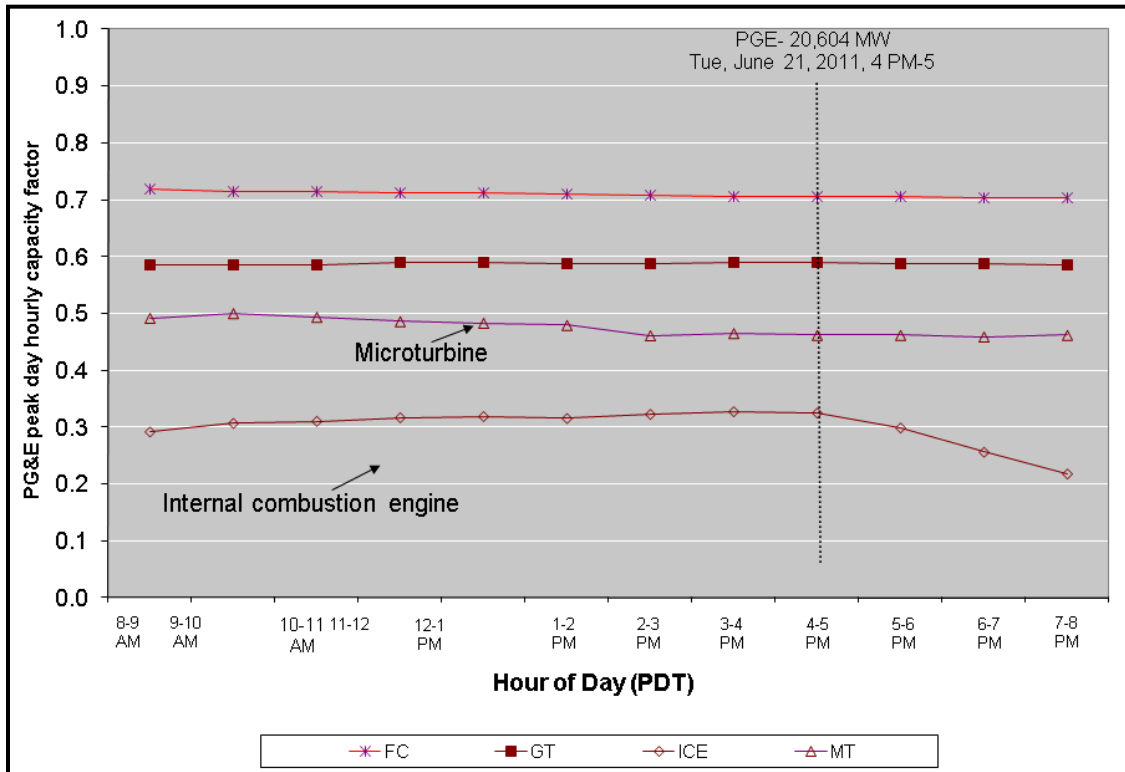
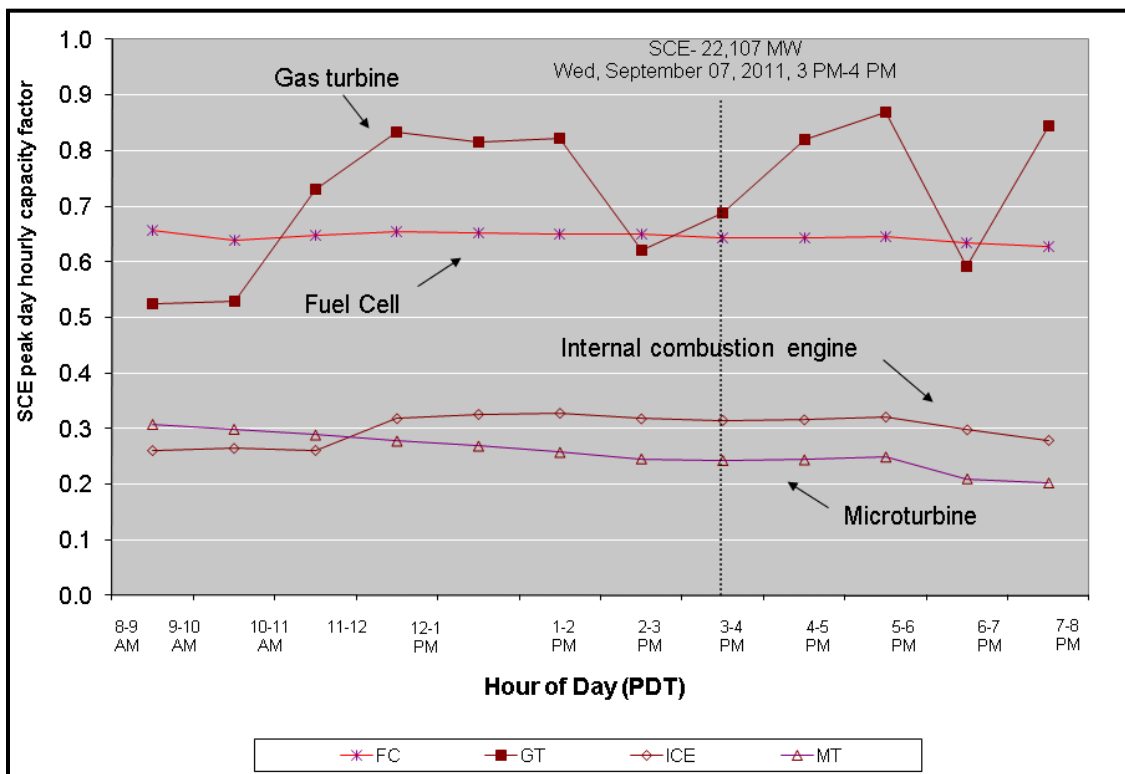
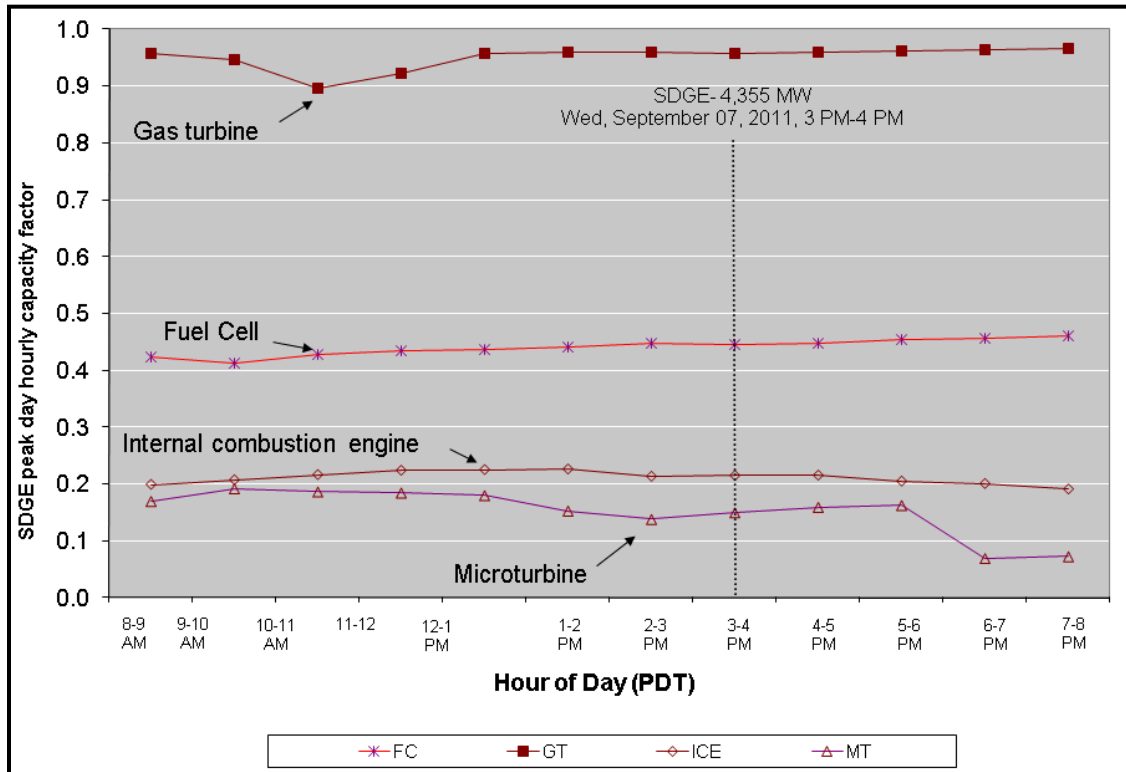


Figure A-8: 2011 IOU Peak Day Capacity Factors by Technology—SCE





**Figure A-9: 2011 IOU Peak Day Capacity Factors by Technology—SDG&E**



## A.2 Renewable Fuel Projects

This section describes impacts of renewable fuel projects. It includes renewable fuel cells, ICE-R, and MT-R. There are no renewable gas turbines in the program. The next section describes non-renewable fuel projects.

### A.2.1 Renewable Fuel Cells

#### Annual Energy

Table A-13 presents annual total net electrical output in GWh from renewable fuel cells for the program and for each PA. This table also shows subtotals by basis (metered and estimated), indicating respectively the subtotal physically metered at the many SGIP sites and the subtotal estimated where metered electrical energy data were not available.

**Table A-13: 2011 Annual Electric Energy Totals by PA**

Technology	Basis	PG&E (GWh)	SCE (GWh)	SCG (GWh)	CCSE (GWh)	Total (GWh)
<b>FCR</b>	<b>Total*</b>	<b>53.6 †</b>	<b>21.3 †</b>	<b>29.5 †</b>	<b>5.2</b>	<b>109.6</b>
	M	48.70	7.23	13.42	1.56	70.91
	E	4.87	14.05	16.13	3.65	38.69

\* <sup>a</sup> indicates confidence is less than 70/30.  
 † indicates confidence is better than 70/30.  
 No symbol indicates confidence is better than 90/10.

Table A-14 presents quarterly total net electrical output in GWh for renewable fuel cells. This table also shows subtotals by basis (metered and estimated), indicating respectively the subtotal physically metered at the many SGIP sites and the subtotal estimated where metered electrical energy data were not available.

**Table A-14: 2011 Quarterly Electric Energy Totals**

Technology	Fuel	Basis	Q1-2011 (GWh)	Q2-2011 (GWh)	Q3-2011 (GWh)	Q4-2011 (GWh)	Total* (GWh)
<b>FC</b>	<b>R</b>	<b>Total</b>	<b>21.4</b>	<b>26.3</b>	<b>30.6</b>	<b>31.4</b>	<b>110</b>
		M	11.7	16.2	18.9	24.1	71
		E	9.6	10.1	11.7	7.3	39

\* <sup>a</sup> indicates confidence is less than 70/30.  
 † indicates confidence is better than 70/30.  
 No symbol indicates confidence is better than 90/10.

**Peak Demand**

Table A-15 presents total net electrical output in kW for renewable fuel cells during the peak hour of 4:00 to 5:00 P.M. (PDT) on September 7, 2011. The table also shows counts of projects and total project capacity in kW.

**Table A-15: 2011 CAISO Peak Hour Demand Impacts**

Technology	Project Count (n)	Capacity (MW)	Impact* (MW)
<b>FCR</b>	37	17.8	14.9 †

\* <sup>a</sup> indicates confidence is less than 70/30. † indicates confidence is better than 70/30.  
 No symbol indicates confidence is better than 90/10.

Table A-16 presents the total net electrical output in MW for renewable fuel cells during the respective peak hours of the three large, investor-owned electric utilities. The table also shows

counts of projects and total project capacity in MW. The table also lists the dates, hours, and loads of the utility’s peak hour day. These results for the three individual electric utilities do not strictly include all projects or only projects administered by the PA associated with the electric utility. The results include only those projects whose output feeds directly into the electric utility’s distribution system.

**Table A-16: 2011 IOU Peak Hours Demand Impacts**

PA	Peak (MW)	Date	Hour (PDT)	Technology	Project Count (n)	Capacity (MW)	Impact (MW)
PG&E	20,604	6/21/2011	16	FCR	16	6.40	5.84
SCE	22,107	9/7/2011	15		12	6.15	4.19

**Capacity Factors**

Weighted average CFs indicate renewable fuel cell performance relative to a project-rebated kW for specific time periods. Table A-17 presents annual weighted average CFs for renewable fuel cells for the year 2011.

**Table A-17: 2011 Annual Capacity Factors**

Technology	Annual Capacity Factor* (kWyear/kWyear)
FCR	0.80

\* <sup>a</sup> indicates confidence is less than 70/30.  
 † indicates confidence is better than 70/30.  
 No symbol indicates confidence is better than 90/10.

Table A-18 presents annual weighted average CFs for renewable fuel cells for each PA for the year 2011.

**Table A-18: 2011 Annual Capacity Factors by PA**

Technology	Annual Capacity Factor			
	PG&E	SCE	SCG	CCSE
	(kWyear/kWyear)			
FCR	0.92 †	0.64 †	0.75 †	0.74

\* <sup>a</sup> indicates confidence is less than 70/30.  
 † indicates confidence is better than 70/30.  
 No symbol indicates confidence is better than 90/10.

Figure A-10 plots profiles of weighted mean monthly CFs for renewable fuel cells for each PA.

**Figure A-10: 2011 Monthly Capacity Factors by PA**

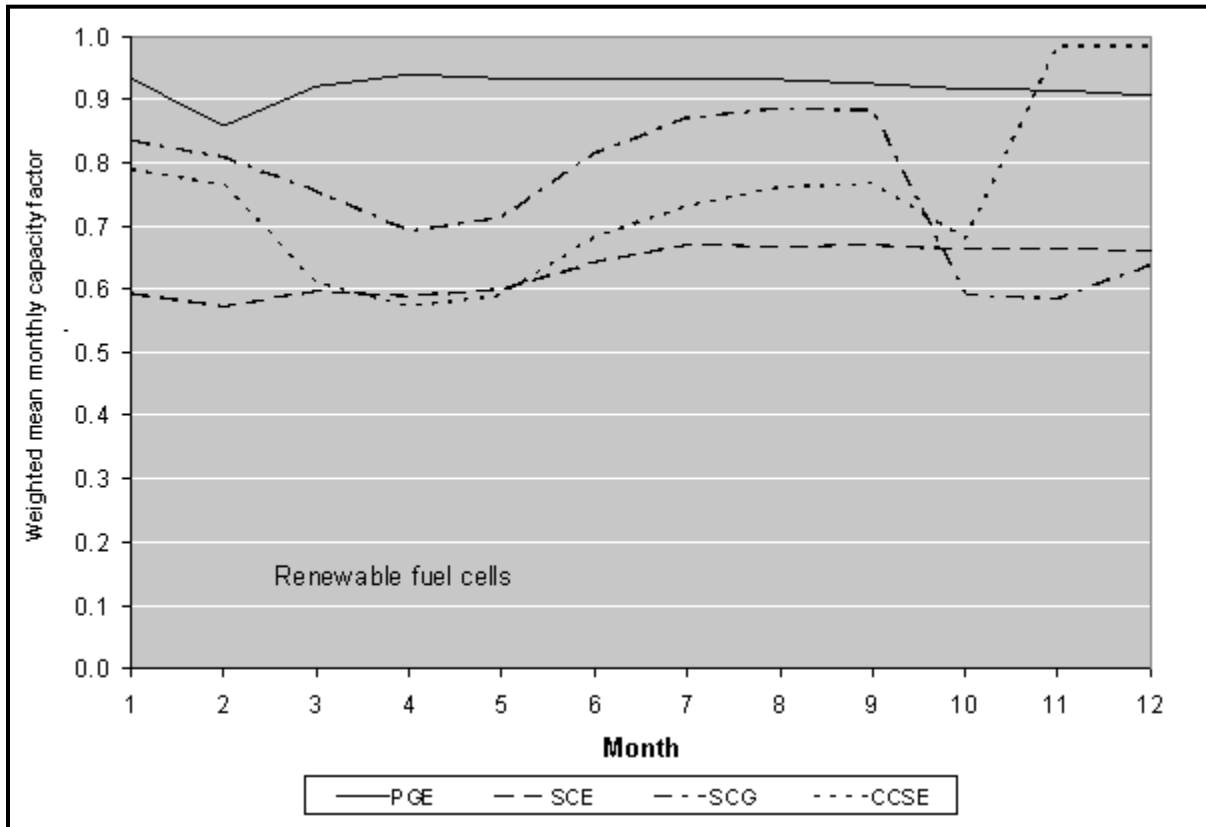


Figure A-11 plots the profiles of hourly weighted average CF for renewable fuel cells for each PA from the morning to early evening during the day of the annual peak hour, September 7, 2011. The chart also shows the profile of the hourly CAISO loads in MW using the vertical axis on the right side of the chart. SCE is the sole PA with renewable fuel cells, so no other PAs appear in the chart.

**Figure A-11: 2011 CAISO Peak Day Capacity Factors by PA**

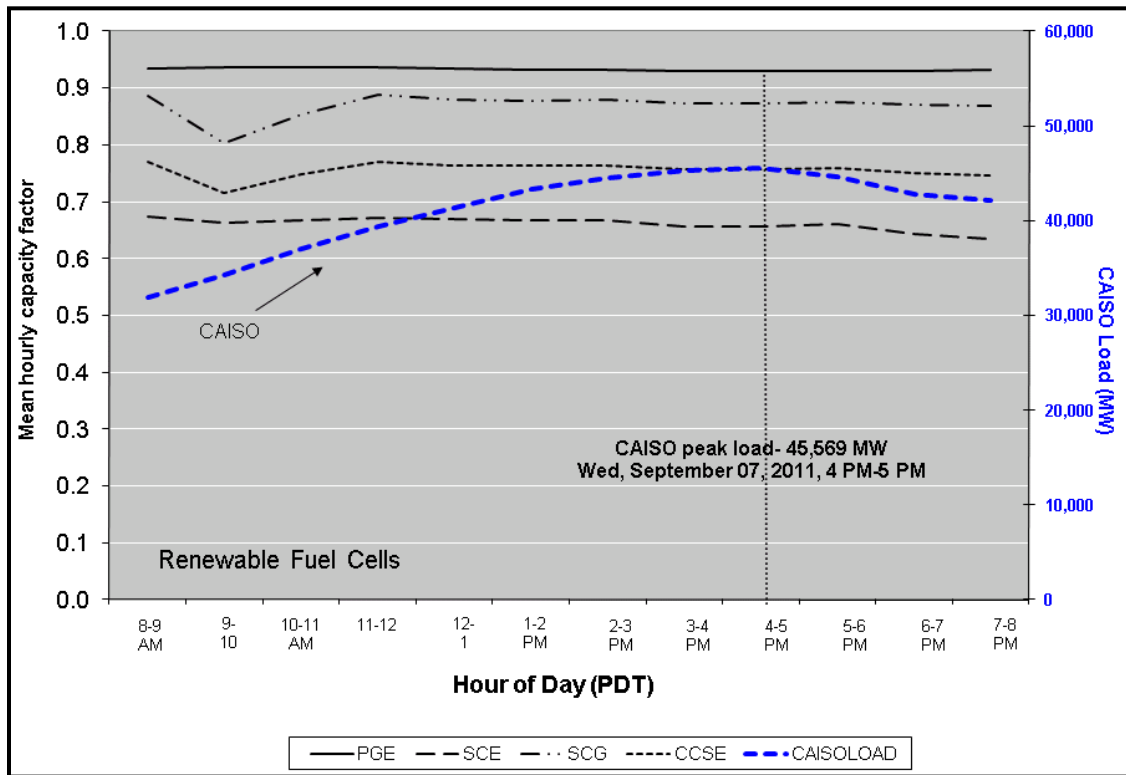
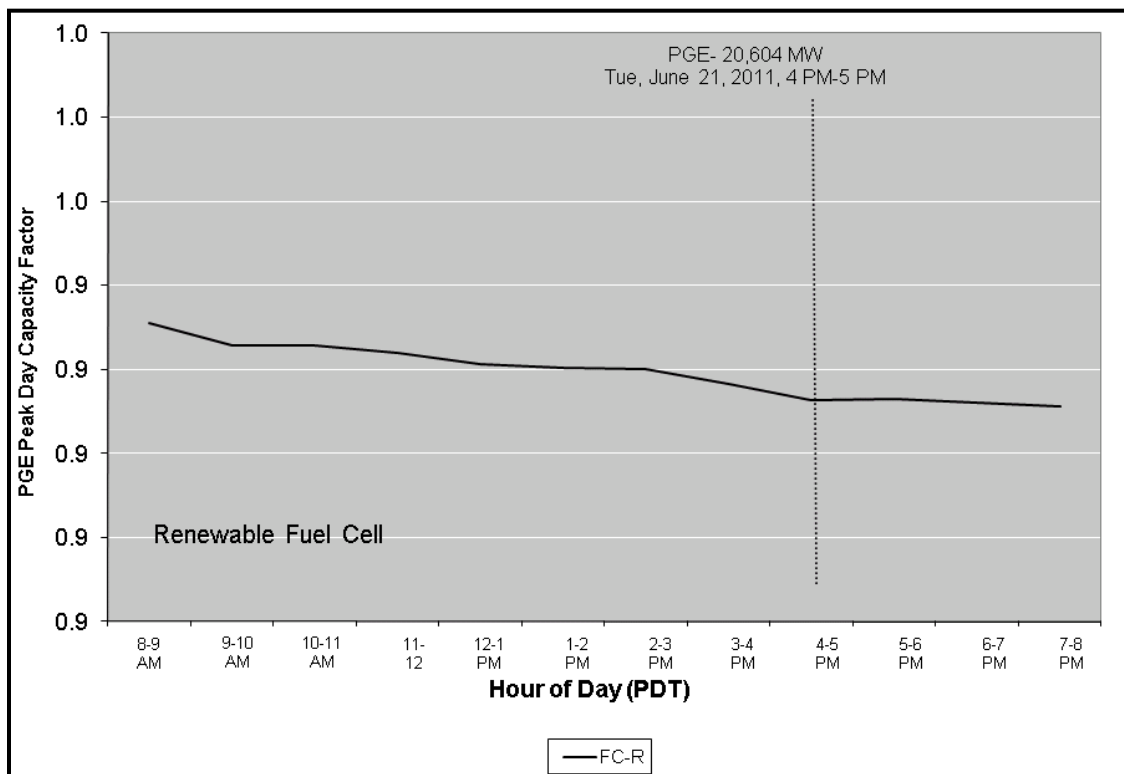


Figure A-12, Figure A-13, and Figure A-14 plot profiles of hourly weighted average CFs for renewable fuel cells directly feeding the electric utilities on the dates of their respective annual peak hours. Projects administered by the PA associated with the electric utility but not feeding directly into its distribution system are not included in these results. The plots also indicate the date and hour and value of the peak load for the electric utility.

**Figure A-12: 2011 IOU Peak Day Capacity Factors—PG&E**



**Figure A-13: 2011 IOU Peak Day Capacity Factors—SCE**

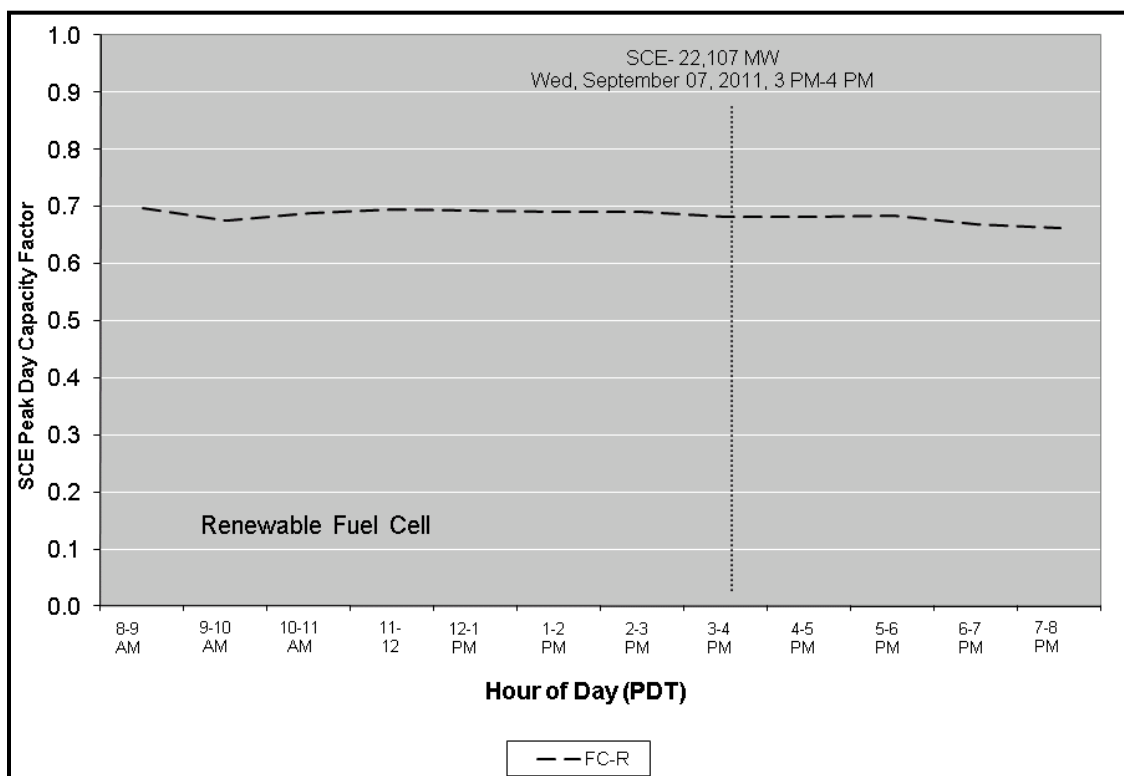
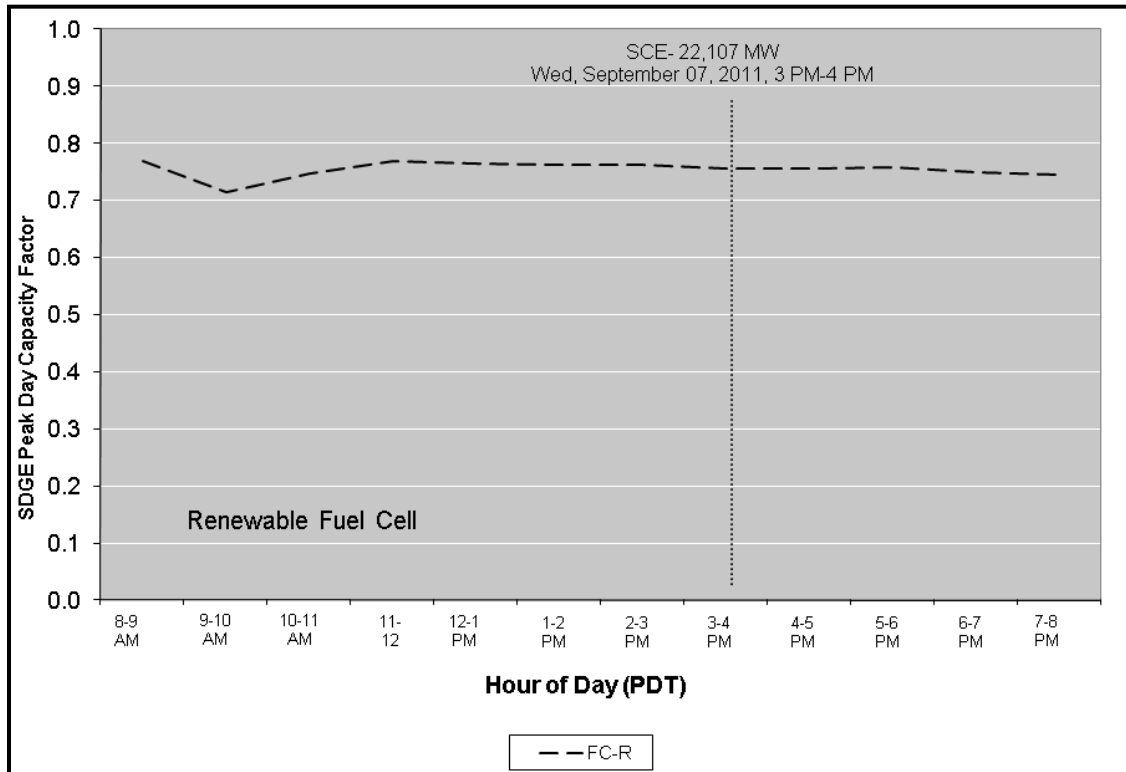


Figure A-14: 2011 IOU Peak Day Capacity Factors—SDG&E



## A.2.2 Renewable Internal Combustion Engines and Microturbines

### Annual Energy

Table A-19 presents annual total net electrical output in GWh from ICE-R and microturbines for the program and for each PA. This table also shows subtotals by basis (metered, and estimated), indicating respectively the subtotal physically metered at the many SGIP sites and the subtotal estimated where metered electrical energy data were not available.

**Table A-19: 2011 Annual Electric Energy Totals by Technology and PA**

Technology	Basis	PG&E (GWh)	SCE (GWh)	SCG (GWh)	CCSE (GWh)	Total (GWh)
<b>ICER</b>	<b>Total*</b>	<b>30.8</b>	<b>14.7</b>	<b>12.1 †</b>	<b>4498</b>	<b>62.1</b>
	M	17.20	7.72	7.42	4.50	36.84
	E	13.60	6.93	4.71	0.00	25.24
Technology	Basis	PG&E (GWh)	SCE (GWh)	SCG (GWh)	CCSE (GWh)	Total (GWh)
<b>MTR</b>	<b>Total*</b>	<b>3.5 †</b>	<b>0.4</b>	<b>0.0</b>	<b>1.0 †</b>	<b>4.9</b>
	M	1.74	0.00	0.00	1.02	2.76
	E	1.77	0.40	0.00	0.02	2.18

\* <sup>a</sup> indicates confidence is less than 70/30.

† indicates confidence is better than 70/30.

No symbol indicates confidence is better than 90/10.



Table A-20 presents quarterly total net electrical output in GWh for ICE-R and microturbines. These tables also show subtotals by basis (metered, and estimated), indicating respectively the subtotal physically metered at the many SGIP sites and the subtotal estimated where metered electrical energy data were not available.

**Table A-20: 2011 Quarterly Electric Energy Totals by Technology**

Technology	Fuel	Basis	Q1-2011 (GWh)	Q2-2011 (GWh)	Q3-2011 (GWh)	Q4-2011 (GWh)	Total* (GWh)
<b>ICE</b>	<b>R</b>	<b>Total</b>	<b>10.8</b>	<b>15.5</b>	<b>17.7</b>	<b>18.1</b>	<b>62</b>
		M	7.2	9.2	10.3	10.2	37
		E	3.5	6.4	7.4	7.9	25 †
Technology	Fuel	Basis	Q1-2011 (GWh)	Q2-2011 (GWh)	Q3-2011 (GWh)	Q4-2011 (GWh)	Total* (GWh)
<b>MT</b>	<b>R</b>	<b>Total</b>	<b>1.2</b>	<b>0.9</b>	<b>1.4</b>	<b>1.4</b>	<b>5</b>
		M	0.6	0.6	0.8	0.8	3
		E	0.6	0.3	0.7	0.6	2 †

\* <sup>a</sup> indicates confidence is less than 70/30.

† indicates confidence is better than 70/30.

No symbol indicates confidence is better than 90/10.

**Peak Demand**

Table A-21 presents total net electrical output in MW for ICE-R and microturbines during the peak hour of 4:00 to 5:00 P.M. (PDT) on September 7, 2011. The table also shows counts of projects and total project capacity in MW.

**Table A-21: 2011 CAISO Peak Hour Demand Impacts by Technology**

Technology	Project Count (n)	Capacity (MW)	Impact* (MW)
<b>ICER</b>	24	14.5	7.1 †
<b>MTR</b>	21	3.8	0.32 †

\* <sup>a</sup> indicates confidence is less than 70/30.

† indicates confidence is better than 70/30.

No symbol indicates confidence is better than 90/10.

Table A-22 presents the total net electrical output in MW for ICE-R and microturbines during the respective peak hours of the three large, investor-owned electric utilities. The table also shows counts of projects and total project capacity in MW. The table also lists the dates, hours, and loads of the utility’s peak hour day. These results for the three individual electric utilities do not strictly include all projects or only projects administered by the PA associated with the electric utility. The results include only those projects whose output feeds directly into the electric utility’s distribution system.

**Table A-22: 2011 IOU Peak Hours Demand Impacts by Technology**

PA	Peak (MW)	Date	Hour (PDT)	Technology	Project Count (n)	Capacity (MW)	Impact (MW)
PG&E	20,604	6/21/2011	16	ICE	15	8.06	2.68
SCE	22,107	9/7/2011	15		8	5.85	1.00
SDG&E	4,355	9/7/2011	15		1	0.56	0.52
PA	Peak (MW)	Date	Hour (PDT)	Technology	Project Count (n)	Capacity (MW)	Impact (MW)
PG&E	20,604	6/21/2011	16	MT	13	1.97	0.116
SCE	22,107	9/7/2011	15		4	1.04	0.019
SDG&E	4,355	9/7/2011	15		4	0.77	0.019

**Capacity Factors**

Weighted average CFs indicate ICE-R and microturbines performances relative to a project-rebated kW for specific time periods. Table A-23 presents annual weighted average CFs for ICE-R and microturbines for the year 2011.

**Table A-23: 2011 Annual Capacity Factors by Technology**

Technology	Annual Capacity Factor* (kWyear/kWyear)
ICER	0.49
MTR	0.15

\* <sup>a</sup> indicates confidence is less than 70/30.  
 † indicates confidence is better than 70/30.  
 No symbol indicates confidence is better than 90/10.

Table A-24 presents annual weighted average CFs for ICE-R and microturbines for each PA for the year 2011.

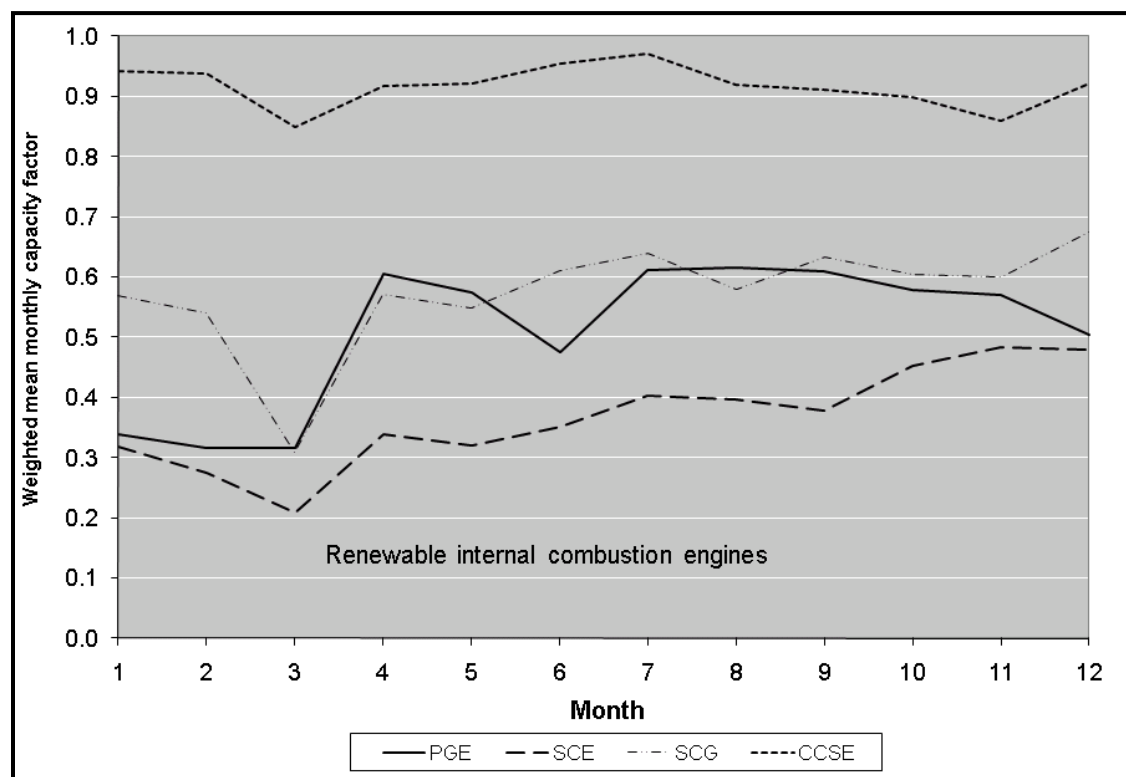
**Table A-24: 2011 Annual Capacity Factors by Technology and PA**

Technology	Annual Capacity Factor			
	PG&E	SCE	SCG	CCSE
	(kWyear/kWyear)			
ICER	0.51	0.37	0.58 †	0.917
MTR	0.20 †	0.04		0.15 †

\* <sup>a</sup> indicates confidence is less than 70/30.  
 † indicates confidence is better than 70/30.  
 No symbol indicates confidence is better than 90/10.

Figure A-15 and Figure A-16 plot profiles of weighted mean monthly CFs for ICE-R and microturbines for each PA.

**Figure A-15: 2011 Monthly Capacity Factors by PA—ICE-R**



**Figure A-16: 2011 Monthly Capacity Factors by PA—MT-R**

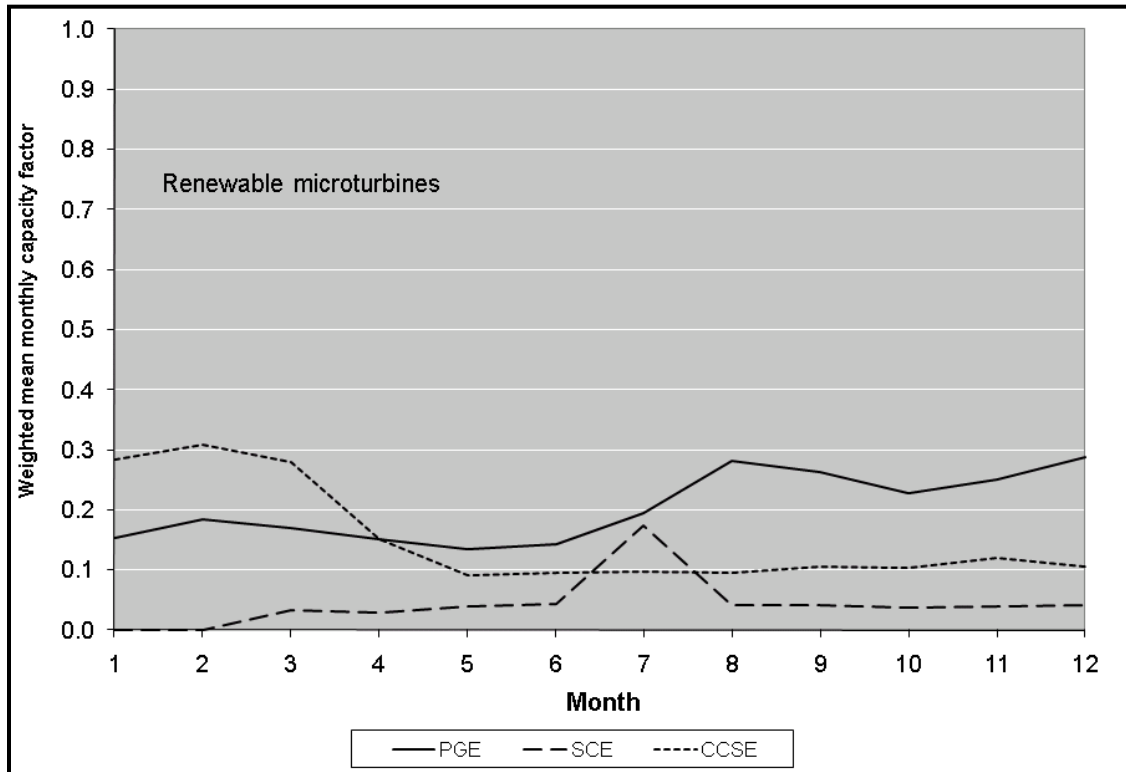


Figure A-17 and Figure A-18 plot the profiles of hourly weighted average CF for ICE-R and microturbines for each PA from the morning to early evening during the day of the annual peak hour, September 7, 2011. The charts also show the profile of the hourly CAISO loads in MW using the vertical axis on the right side of the charts.

Figure A-17: 2011 CAISO Peak Day Capacity Factors by PA—ICE-R

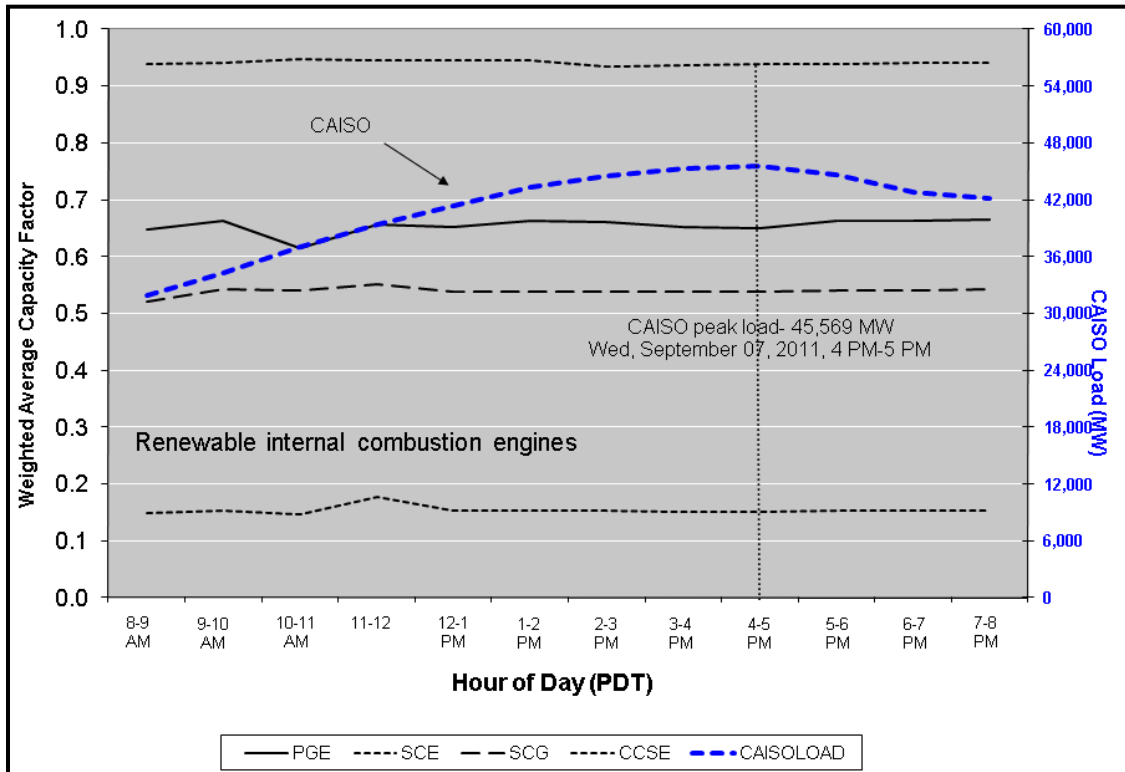


Figure A-18: 2011 CAISO Peak Day Capacity Factors by PA—MT-R

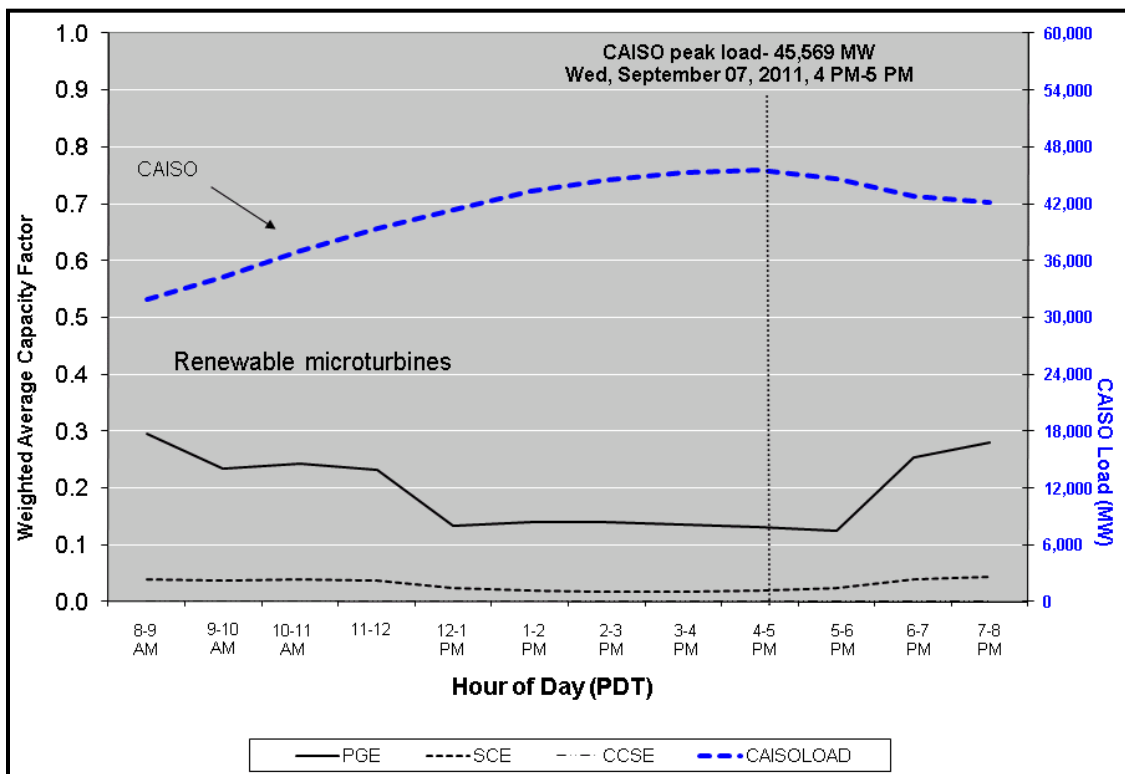


Figure A-19, Figure A-20, and Figure A-21 plot profiles of hourly weighted average CFs for ICE-R and microturbines directly feeding the electric utilities on the dates of their respective annual peak hours. Projects administered by the PA associated with the electric utility but not feeding directly into its distribution system are not included in these results. The plots also indicate the date and hour and value of the peak load for the electric utility.

**Figure A-19: 2011 IOU Peak Day Capacity Factors by Technology—PG&E**

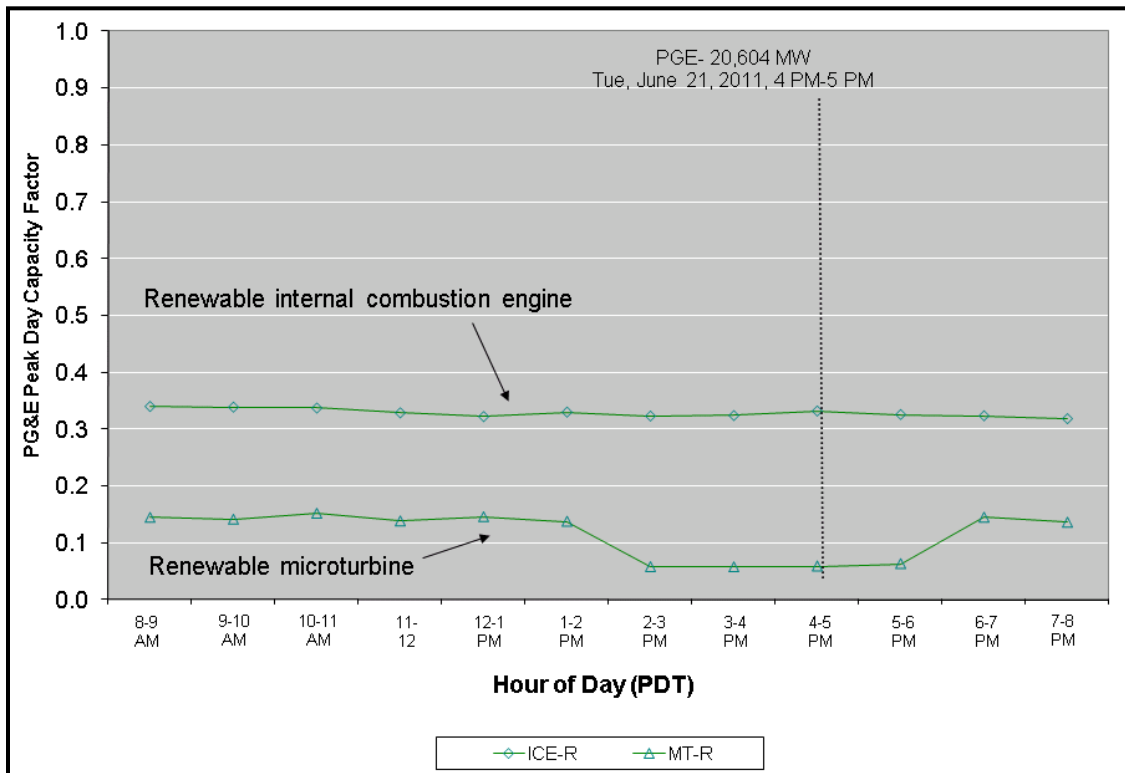


Figure A-20: 2011 IOU Peak Day Capacity Factors by Technology—SCE

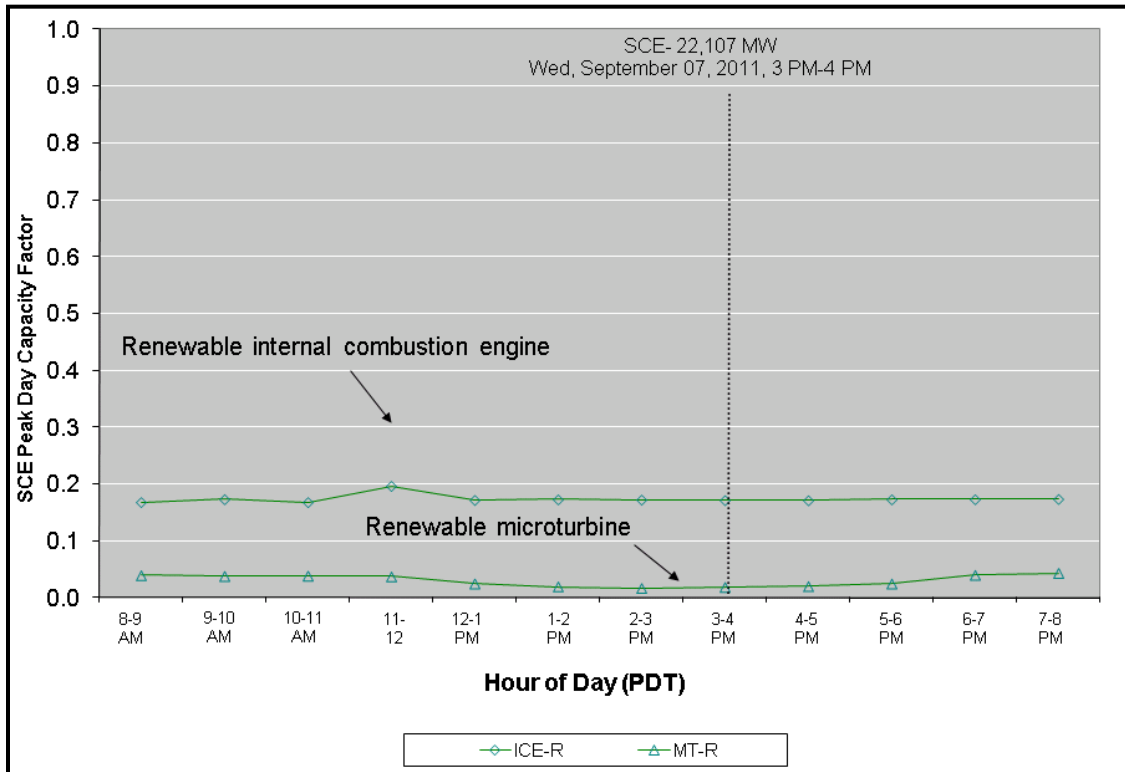
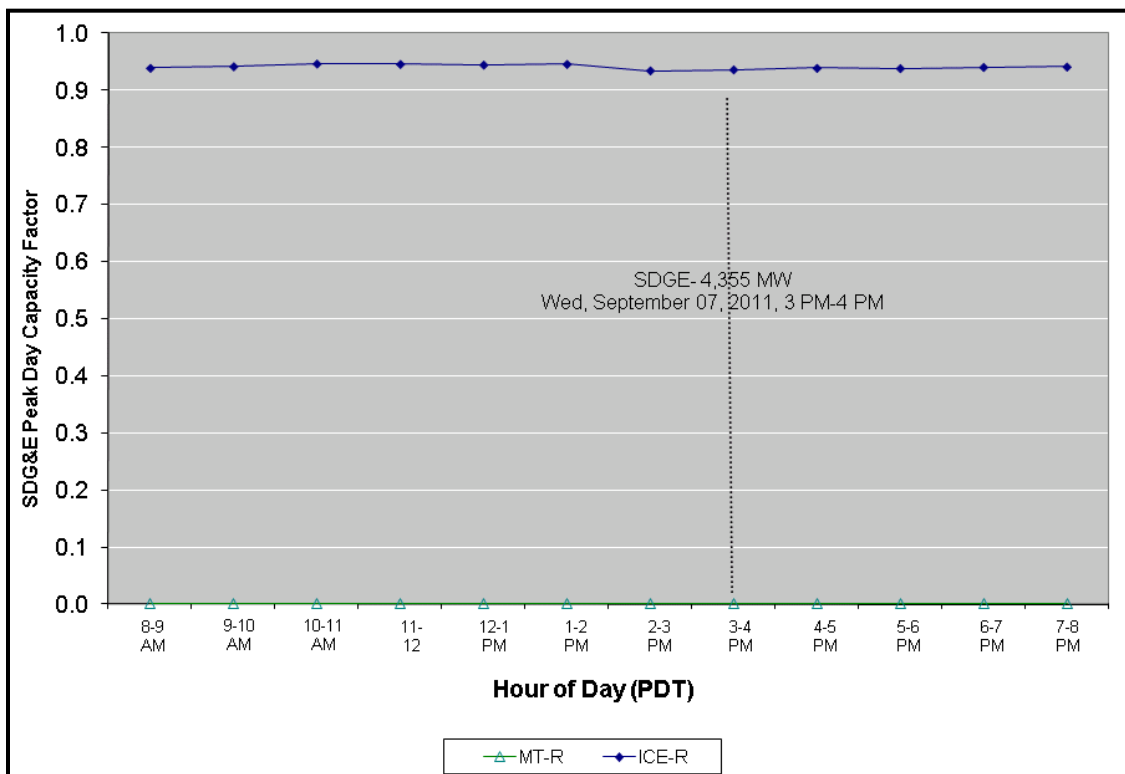


Figure A-21: 2011 IOU Peak Day Capacity Factors by Technology—SDG&E



### A.3 Non-Renewable Fuel Projects

This section describes impacts of non-renewable fuel projects. It begins with fuel cells and proceeds to gas turbines, IC engines, and microturbines.

#### A.3.1 Non-renewable Fuel Cells

##### Annual Energy

Table A-25 presents annual total net electrical output in GWh from FC-N for the program and for each PA. This table also shows subtotals by basis (metered, and estimated), indicating respectively the subtotal physically metered at the many SGIP sites and the subtotal estimated where metered electrical energy data were not available.

**Table A-25: 2011 Annual Electric Energy Totals by PA**

Technology	Basis	PG&E (GWh)	SCE (GWh)	SCG (GWh)	CCSE (GWh)	Total (GWh)
FCN	<b>Total*</b>	<b>44.8</b>	<b>5.4</b>	<b>10.6</b>	<b>6.8</b>	<b>67.6</b>
	M	20.8	2.4	6.5	6.8	36.4
	E	24.0	3.0	4.1	0.0	31.2

\* <sup>a</sup> indicates confidence is less than 70/30.

† indicates confidence is better than 70/30.

No symbol indicates confidence is better than 90/10.

Table A-26 presents quarterly total net electrical output in GWh for FC-N. This table also shows subtotals by basis (metered, and estimated), indicating respectively the subtotal physically metered at the many SGIP sites and the subtotal estimated where metered electrical energy data were not available.

**Table A-26: 2011 Quarterly Electric Energy Totals**

Technology	Fuel	Basis	Q1-2011 (GWh)	Q2-2011 (GWh)	Q3-2011 (GWh)	Q4-2011 (GWh)	Total* (GWh)
FC	N	<b>Total</b>	<b>13.7</b>	<b>16.7</b>	<b>19.4</b>	<b>17.8</b>	<b>68</b>
		M	6.7	9.2	10.5	10.0	36
		E	7.0	7.5	8.9	7.7	31

\* <sup>a</sup> indicates confidence is less than 70/30.

† indicates confidence is better than 70/30.

No symbol indicates confidence is better than 90/10.



**Peak Demand**

Table A-27 presents total net electrical output in MW for FC-N during the peak hour of 4:00 to 5:00 P.M. (PDT) on September 7, 2011. The table also shows counts of projects and total project capacity in MW.

**Table A-27: 2011 CAISO Peak Hour Demand Impacts**

Technology	Project Count (n)	Capacity (MW)	Impact* (MW)
FCN	76	14.2	7.7

\* <sup>a</sup> indicates confidence is less than 70/30.  
 † indicates confidence is better than 70/30.  
 No symbol indicates confidence is better than 90/10.

Table A-28 presents the total net electrical output in MW for FC-N during the respective peak hours of the three large, investor-owned electric utilities. The table also shows counts of projects and total project capacity in MW. The table also lists the dates, hours, and loads of the utility’s peak hour day. These results for the three IOU do not strictly include all projects or only projects administered by the PA closely associated with the IOU. The results include only those projects whose output feeds directly into the electric utility’s distribution system.

**Table A-28: 2011 IOU Peak Hours Demand Impacts**

IOU	Peak (MW)	Date	Hour (PDT)	Technology	Project Count (n)	Capacity (MW)	Impact (MW)
PG&E	20,604	6/21/2011	16	FC	27	6.59	3.31
SCE	22,107	9/7/2011	15	FC	12	1.30	0.59
SDG&E	4,355	9/7/2011	15	FC	5	2.26	0.75

**Capacity Factors**

Weighted average CFs indicate FC-N performance relative to a project-rebated kW for specific time periods. Table A-29 presents annual weighted average CFs for FC-N for the year 2011.

**Table A-29: 2011 Annual Capacity Factors**

Technology	Annual Capacity Factor* (kWyear/kWyear)
FCN	0.55

\* <sup>a</sup> indicates confidence is less than 70/30.  
 † indicates confidence is better than 70/30.  
 No symbol indicates confidence is better than 90/10.

Table A-30 presents annual weighted average CFs for FC-N for each PA for the year 2011.

**Table A-30: 2011 Annual Capacity Factors by PA**

Technology	Annual Capacity Factor			
	PG&E	SCE	SCG	CCSE
	(kWyear/kWyear)			
FCN	0.58	0.71	0.58	0.33

\* <sup>a</sup> indicates confidence is less than 70/30.  
 † indicates confidence is better than 70/30.  
 No symbol indicates confidence is better than 90/10.

Figure A-22 plots profiles of weighted mean monthly CFs for FC-N for each PA.

**Figure A-22: 2011 Monthly Capacity Factors by Technology and PA**

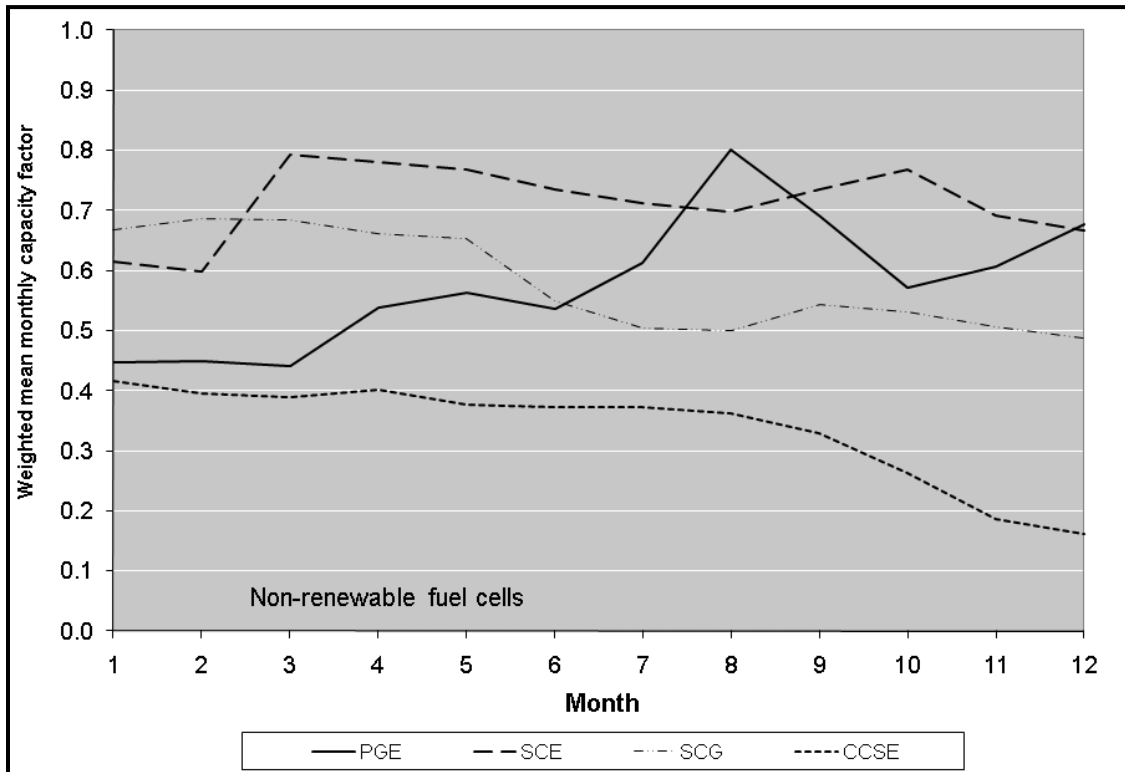


Figure A-23 plots the profiles of hourly weighted average CF for FC-N for each PA from the morning to early evening during the day of the annual peak hour, September 7, 2011. The chart also shows the profile of the hourly CAISO loads in MW using the vertical axis on the right side of the chart.

**Figure A-23: 2011 CAISO Peak Day Capacity Factors by PA**

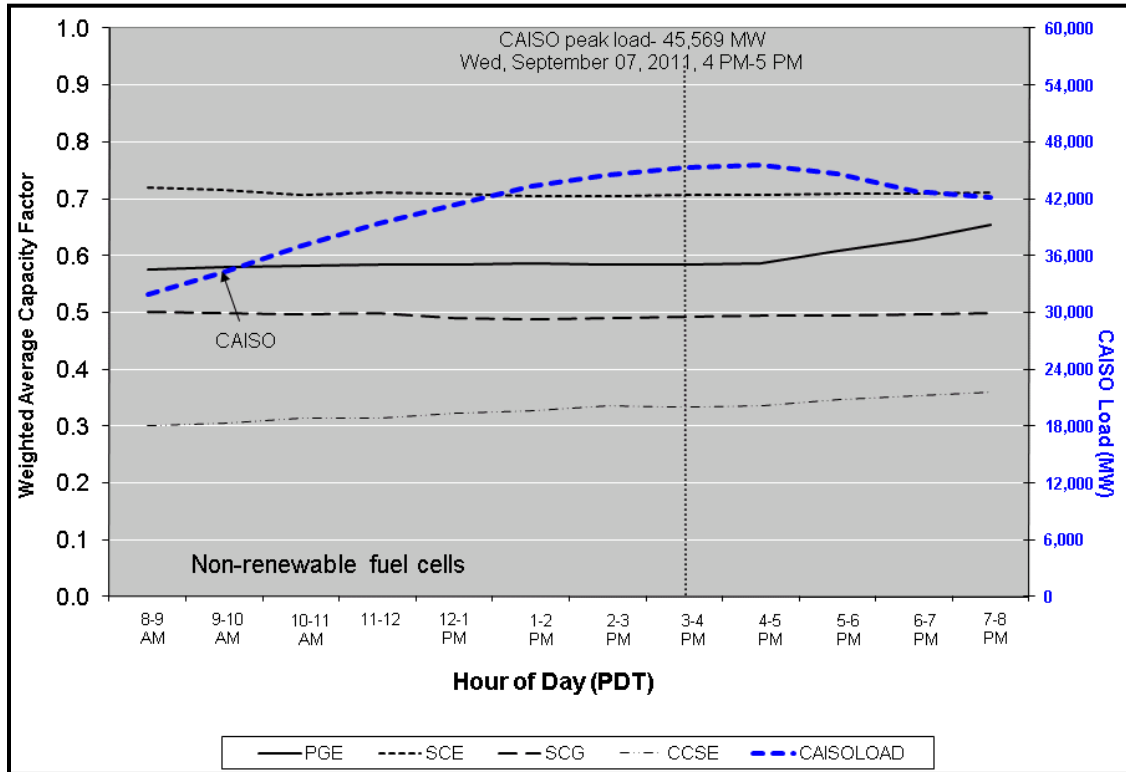
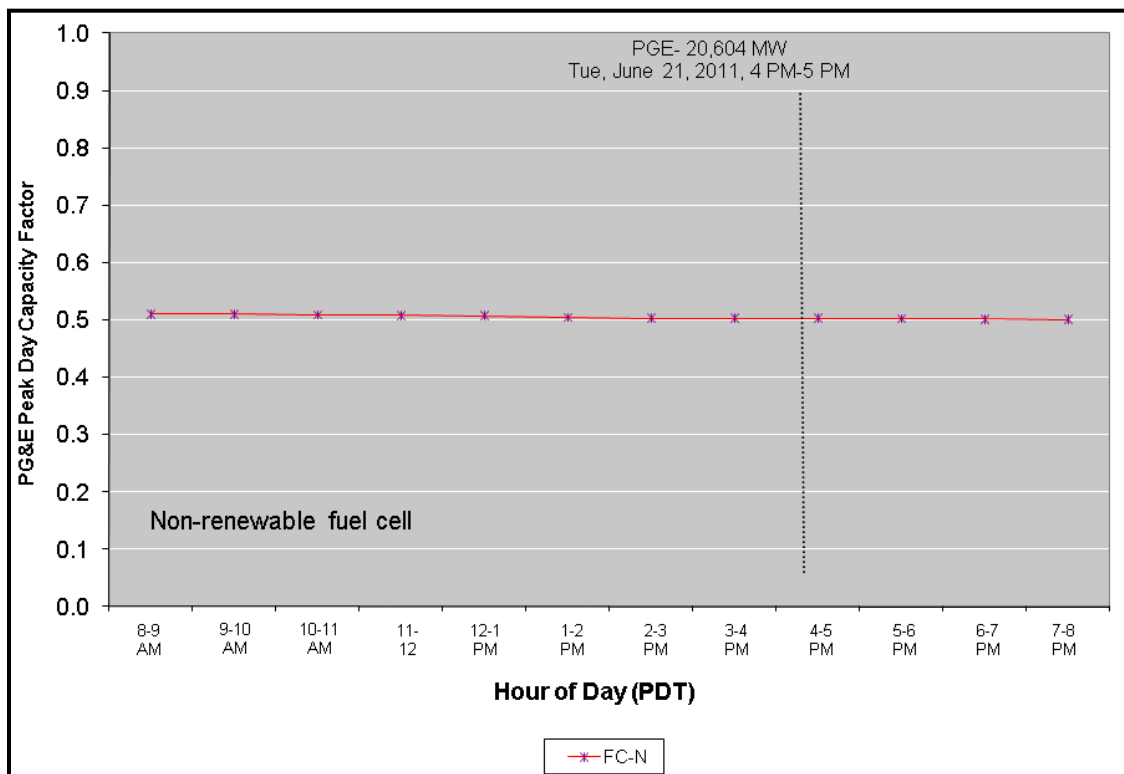


Figure A-24, Figure A-25, and Figure A-26 plot profiles of hourly weighted average CFs for FC-N directly feeding the electric utilities on the dates of their respective annual peak hours. Projects administered by the PA associated with the electric utility but not feeding directly into its distribution system are not included in these results. The plots also indicate the date and hour and value of the peak load for the electric utility.

**Figure A-24: 2011 IOU Peak Day Capacity Factors—PG&E**



**Figure A-25: 2011 IOU Peak Day Capacity Factors—SCE**

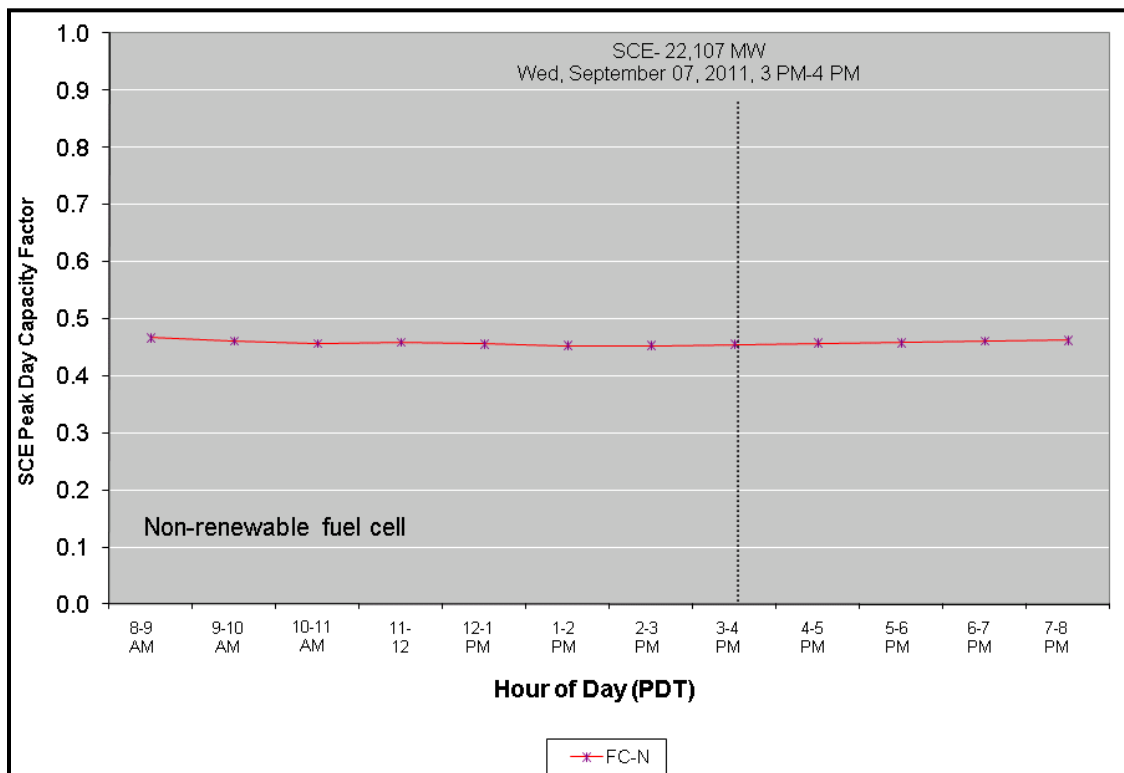
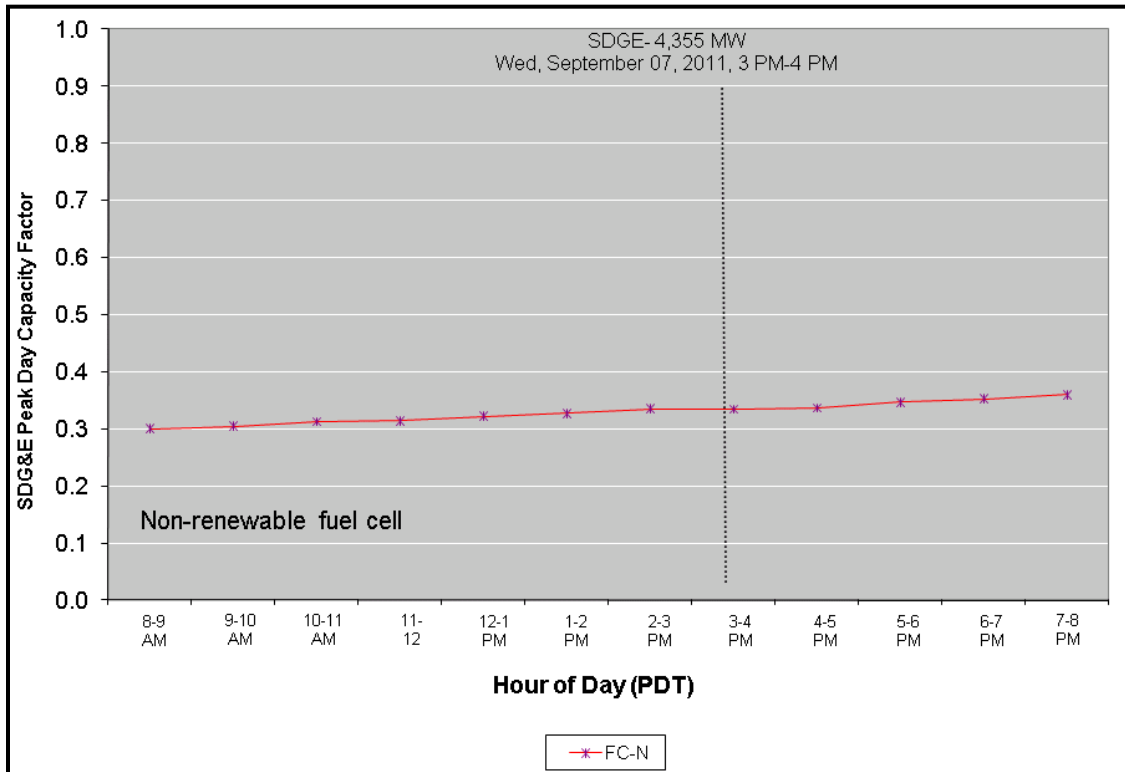


Figure A-26: 2011 IOU Peak Day Capacity Factors—SDG&E



### A.3.2 Non-renewable Gas Turbines, Internal Combustion Engines, and Microturbines

#### Annual Energy

Table A-31 presents annual total net electrical output in GWh from GT, ICE-N, and MT-N projects for the program and for each PA. This table also shows subtotals by basis (metered, and estimated), indicating respectively the subtotal physically metered at the many SGIP sites and the subtotal estimated where metered electrical energy data were not available.

**Table A-31: 2011 Annual Electric Energy Totals by PA**

Technology	Basis	PG&E (GWh)	SCE (GWh)	SCG (GWh)	CCSE (GWh)	Total (GWh)
<b>GT</b>	<b>Total*</b>	<b>19.3 †</b>		<b>91.9</b>	<b>76.1</b>	<b>187.3</b>
	M	0.0		83.5	76.1	159.5
	E	19.3		8.5	0.0	27.8
<b>ICEN</b>	<b>Total*</b>	<b>112.2</b>	<b>36.1</b>	<b>99.8</b>	<b>8.8</b>	<b>256.9</b>
	M	42.7	16.0	58.6	8.8	126.1
	E	69.5	20.1	41.2	0.0	130.8
<b>MTN</b>	<b>Total*</b>	<b>40.5</b>	<b>9.4 †</b>	<b>19.3</b>	<b>1.8</b>	<b>71.1</b>
	M	24.3	5.5	16.1	1.8	47.7
	E	16.2	3.9	3.3	0.0	23.4
	<b>Total</b>	<b>172.0</b>	<b>45.5</b>	<b>211.0</b>	<b>86.7</b>	<b>515.3</b>

\* <sup>a</sup> indicates confidence is less than 70/30.

† indicates confidence is better than 70/30.

No symbol indicates confidence is better than 90/10.

Table A-32 presents quarterly total net electrical output in GWh for GT, ICE-N, and MT-N projects. These tables also show subtotals by basis (metered, and estimated), indicating respectively the subtotal physically metered at the many SGIP sites and the subtotal estimated where metered electrical energy data were not available.

**Table A-32: 2011 Quarterly Electric Energy Totals**

Technology	Fuel	Basis	Q1-2011 (GWh)	Q2-2011 (GWh)	Q3-2011 (GWh)	Q4-2011 (GWh)	Total* (GWh)
<b>ICE</b>	<b>N</b>	<b>Total</b>	<b>56.8</b>	<b>60.7</b>	<b>77.6</b>	<b>61.8</b>	<b>257</b>
		M	22.6	30.3	41.0	32.2	126
		E	34.2	30.4	36.7	29.6	131
<b>GT</b>	<b>N</b>	<b>Total</b>	<b>43.7</b>	<b>47.0</b>	<b>46.6</b>	<b>50.1</b>	<b>187</b>
		M	38.8	41.5	41.3	37.9	160
		E	5.0	5.4	5.3	12.2	28 †
<b>MT</b>	<b>N</b>	<b>Total</b>	<b>13.9</b>	<b>19.0</b>	<b>18.0</b>	<b>20.2</b>	<b>71</b>
		M	8.5	13.0	12.3	13.9	48
		E	5.4	6.0	5.7	6.3	23 †

\* <sup>a</sup> indicates confidence is less than 70/30.

† indicates confidence is better than 70/30.

No symbol indicates confidence is better than 90/10.

**Peak Demand**

Table A-33 presents total net electrical output in MW for GT, ICE-N, and MT-N projects during the peak hour of 4:00 to 5:00 P.M. (PDT) on September 7, 2011. The table also shows counts of projects and total project capacity in MW.

**Table A-33: 2011 CAISO Peak Hour Demand Impacts**

<b>Technology</b>	<b>Project Count (n)</b>	<b>Capacity (MW)</b>	<b>Impact* (MW)</b>
<b>GT</b>	8	25.7	21.3
<b>ICEN</b>	230	141.3	45.9
<b>MTN</b>	119	21.0	8.2
<b>Total</b>	357	188.0	75.5

\* Except for the total, <sup>a</sup> indicates confidence is less than 70/30.

† indicates confidence is better than 70/30.

No symbol indicates confidence is better than 90/10.

Table A-34 presents the total net electrical output in MW for GT, ICE-N, and MT-N projects during the respective peak hours of the three large, investor-owned electric utilities. The table also shows counts of projects and total project capacity in MW. The table also lists the dates, hours, and loads of the utility’s peak hour day. These results for the three individual electric utilities do not strictly include all projects or only projects administered by the PA associated with the electric utility. The results include only those projects whose output feeds directly into the electric utility’s distribution system.

**Table A-34: 2011 IOU Peak Hours Demand Impacts**

<b>IOU</b>	<b>Peak (MW)</b>	<b>Date</b>	<b>Hour (PDT)</b>	<b>Technology</b>	<b>Project Count (n)</b>	<b>Capacity (MW)</b>	<b>Impact (MW)</b>
PG&E	20,604	6/21/2011	16	<b>GT</b>	3	4.0	2.4
				<b>ICEN</b>	103	57.2	18.5
				<b>MTN</b>	45	8.7	4.8
				<b>Total</b>	151	69.9	25.7
SCE	22,107	9/7/2011	15	<b>GT</b>	3	12.6	8.7
				<b>ICEN</b>	97	67.7	22.2
				<b>MTN</b>	52	8.9	2.4
				<b>Total</b>	152	89.2	33.3
SDG&E	4,355	9/7/2011	15	<b>GT</b>	2	9.1	8.7
				<b>ICEN</b>	21	12.1	2.2
				<b>MTN</b>	13	1.1	0.3
				<b>Total</b>	36	22.4	11.2

**Capacity Factors**

Weighted average CFs indicate GT, ICE-N, and MT-N projects performance relative to a project-rebated kW for specific time periods. Table A-35 presents annual weighted average CFs for GT, ICE-N, and MT-N projects for the year 2011.

**Table A-35: 2011 Annual Capacity Factors**

<b>Technology</b>	<b>Annual Capacity Factor* (kWyear/kWyear)</b>
<b>GT</b>	0.83
<b>ICEN</b>	0.21
<b>MTN</b>	0.39

\* <sup>a</sup> indicates confidence is less than 70/30.  
 † indicates confidence is better than 70/30.  
 No symbol indicates confidence is better than 90/10.

Table A-36 presents annual weighted average CFs for GT, ICE-N, and MT-N projects for each PA for the year 2011.

**Table A-36: 2011 Annual Capacity Factors by Technology and PA**

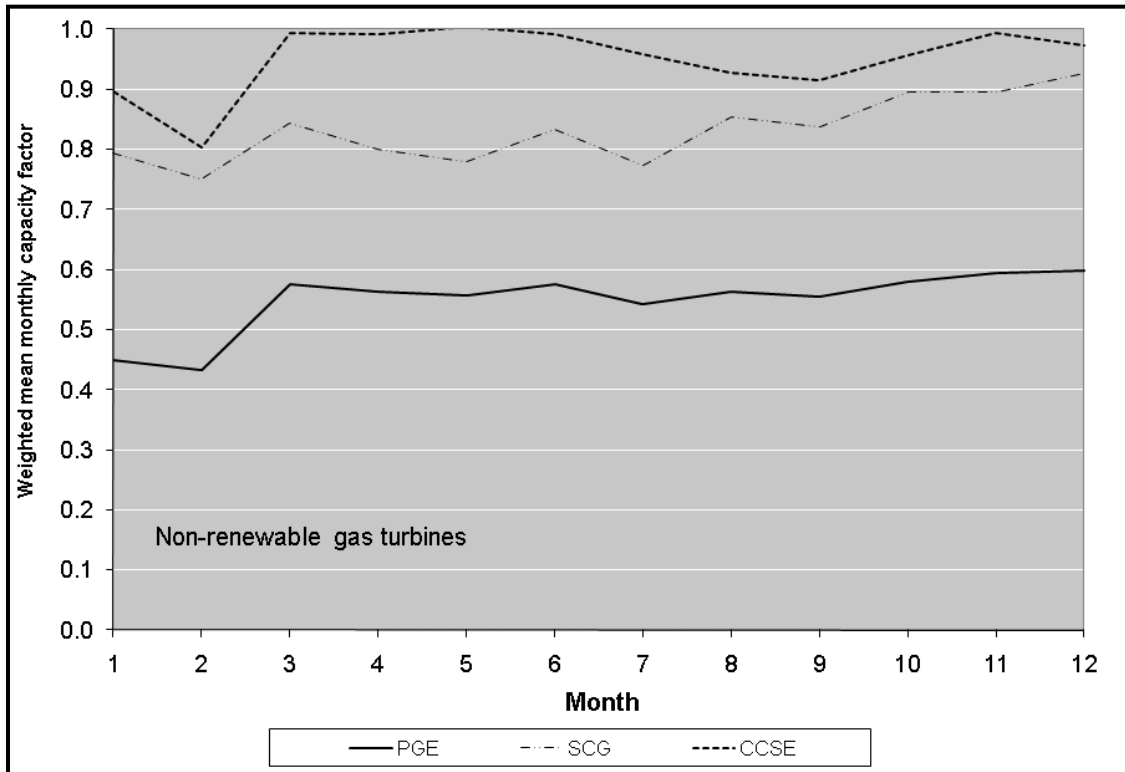
<b>Technology</b>	<b>Annual Capacity Factor</b>			
	<b>PG&amp;E</b>	<b>SCE</b>	<b>SCG</b>	<b>CCSE</b>
	<b>(kWyear/kWyear)</b>			
<b>GTN</b>	0.55 †		0.83	0.95
<b>ICEN</b>	0.23	0.16	0.23	0.09
<b>MTN</b>	0.51	0.25	0.35	0.19

\* <sup>a</sup> indicates confidence is less than 70/30.  
 † indicates confidence is better than 70/30.  
 No symbol indicates confidence is better than 90/10.

Figure A-27, Figure A-28, and Figure A-29 plot profiles of weighted mean monthly CFs for GT, ICE-N, and MT-N projects for each PA.



**Figure A-27: 2011 Monthly Capacity Factors by Technology—GT**



**Figure A-28: 2011 Monthly Capacity Factors by Technology—ICE-N**

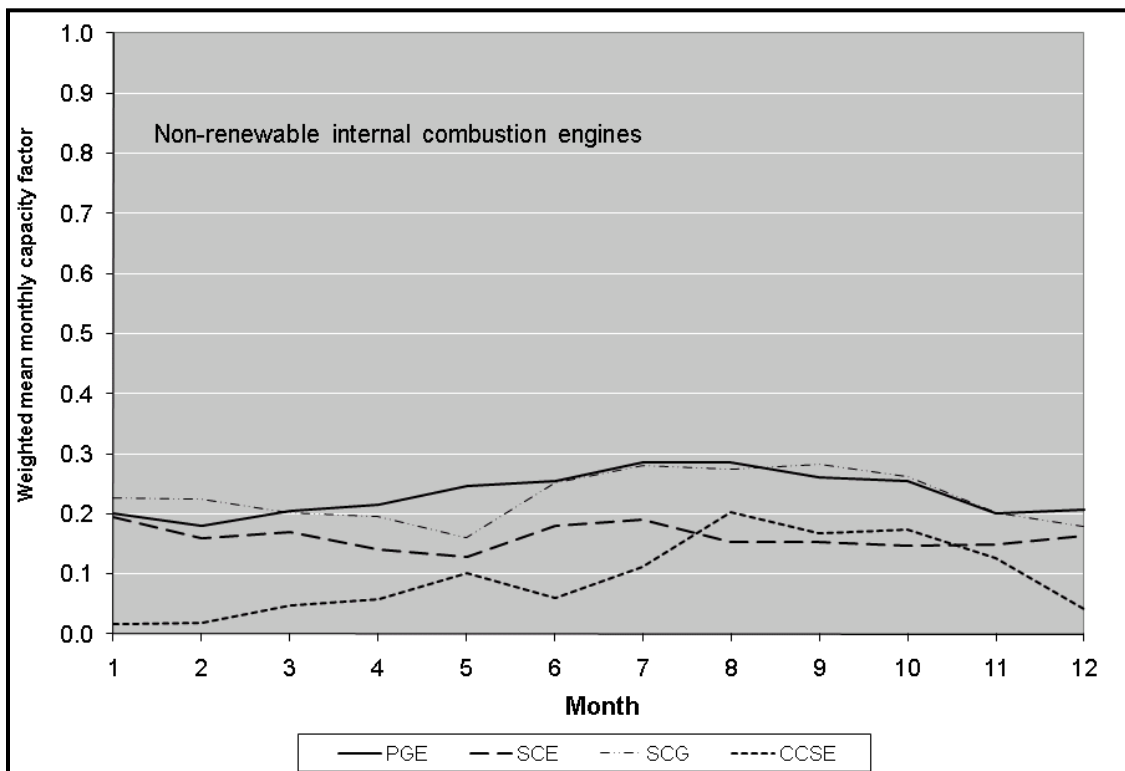


Figure A-29: 2011 Monthly Capacity Factors by Technology—MT-N

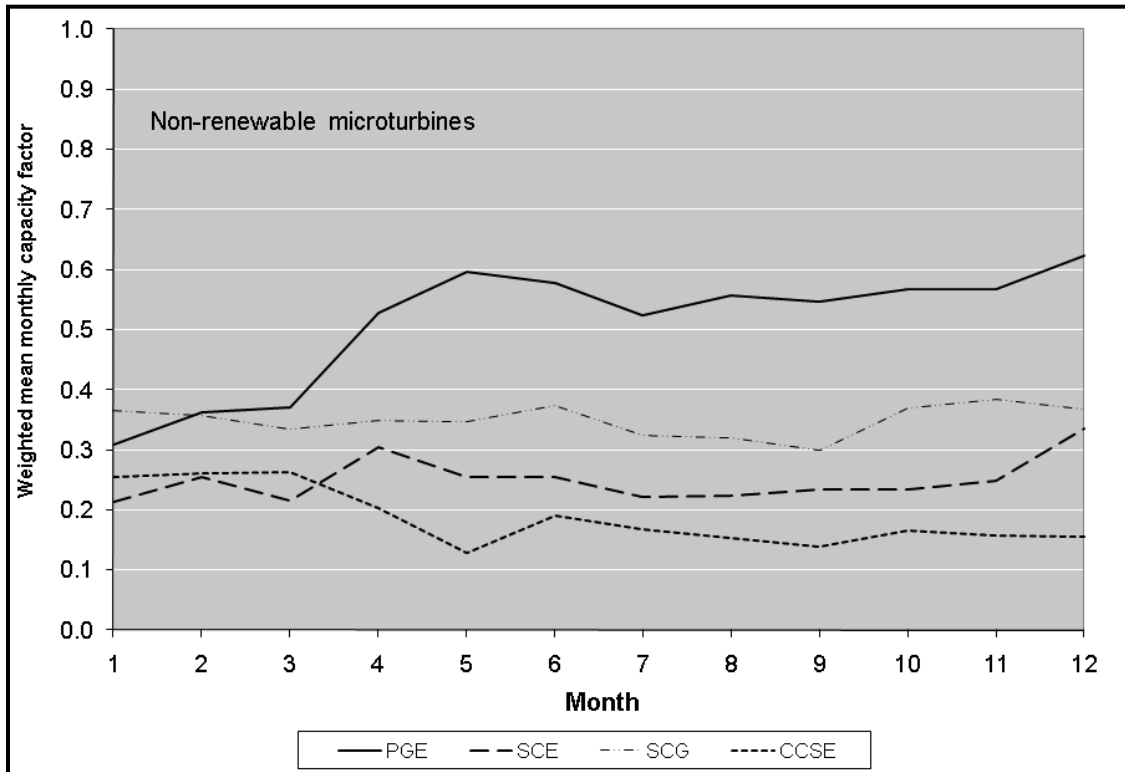


Figure A-30 plots the profiles of hourly weighted average CF for GT, ICE-N, and MT-N projects from the morning to early evening during the day of the annual peak hour, September 7, 2011. The charts also show the profile of the hourly CAISO loads in MW using the vertical axis on the right side of the chart.

**Figure A-30: 2011 CAISO Peak Day Capacity Factors by Technology**

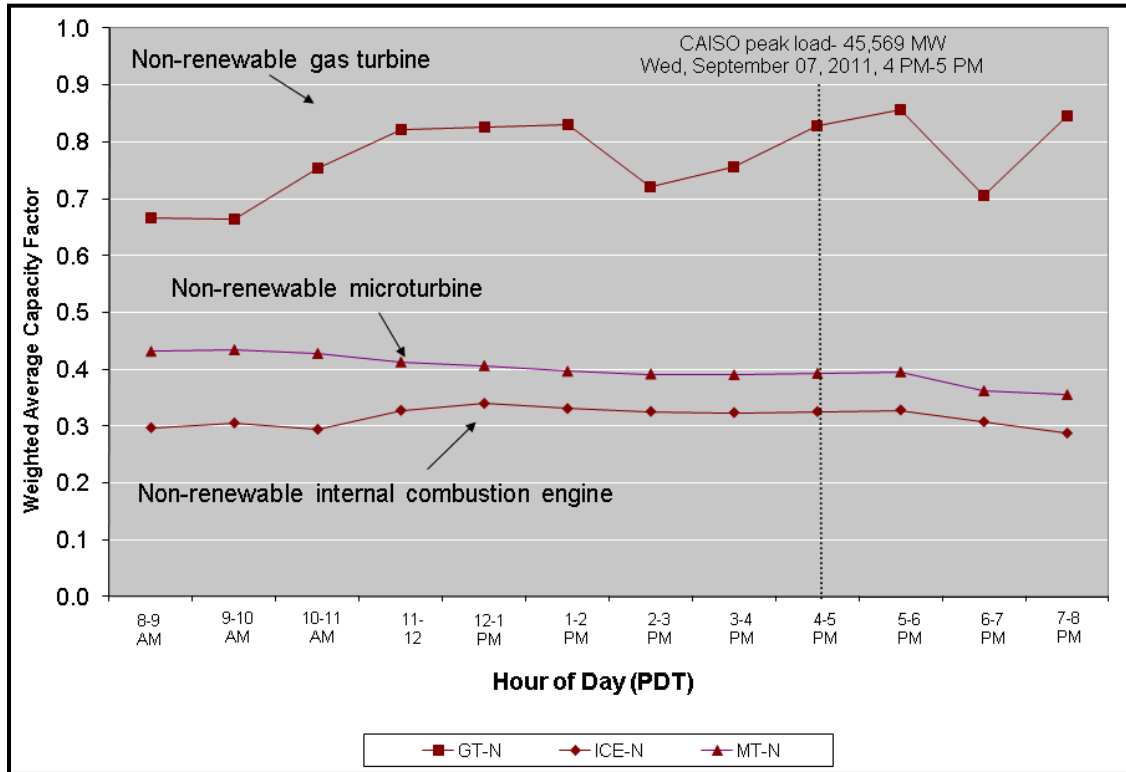
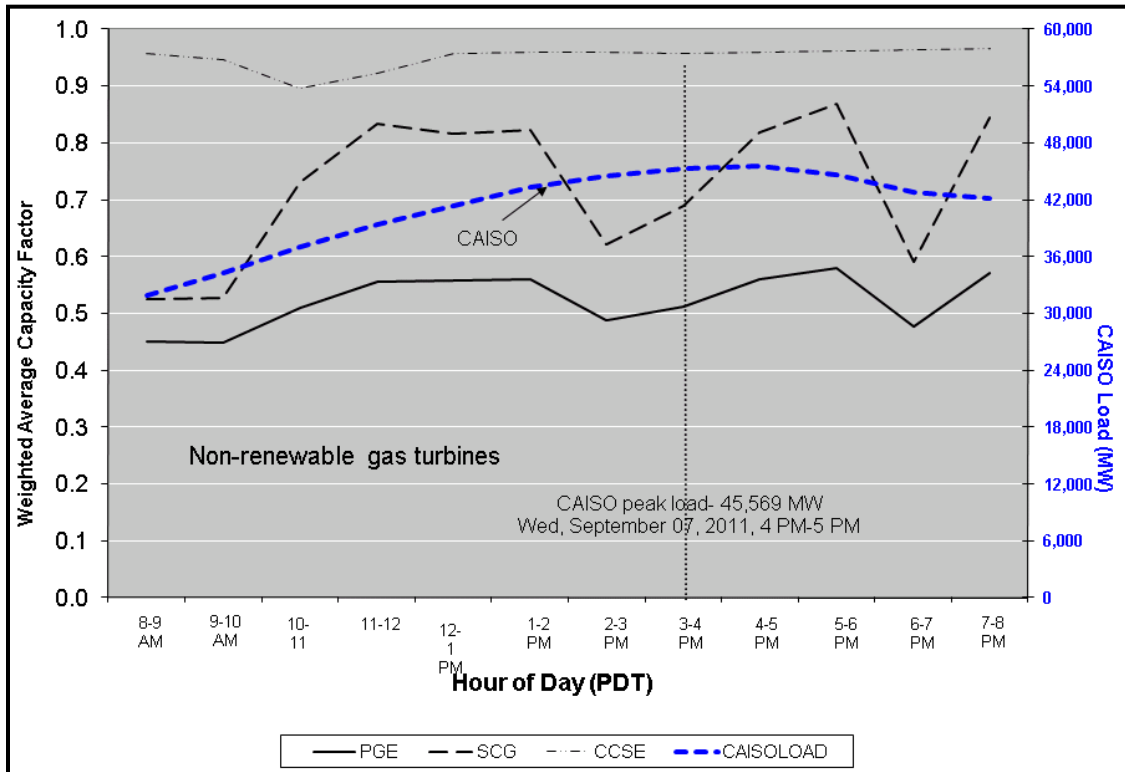
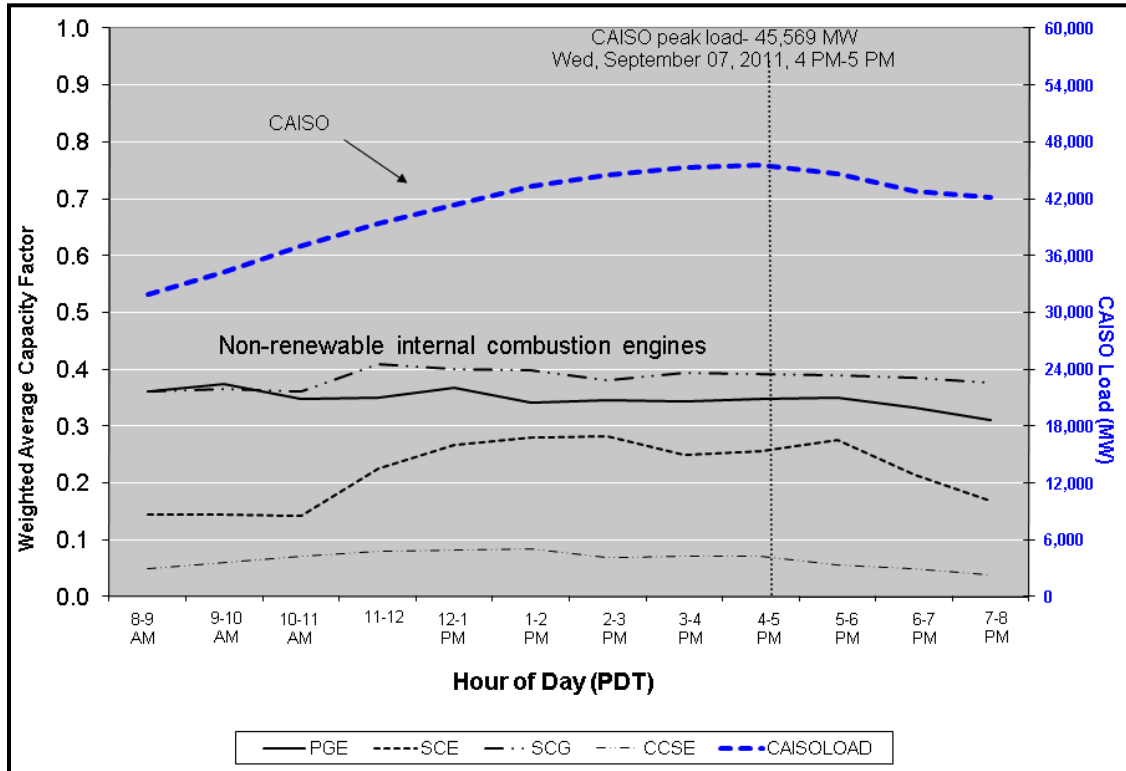


Figure A-31, Figure A-32, and Figure A-33 plot the profiles of hourly weighted average CF for GT, ICE-N, and MT-N projects for each PA from the morning to early evening during the day of the annual peak hour, September 7, 2011. The charts also show the profile of the hourly CAISO loads in MW using the vertical axis on the right side of the chart.

Figure A-31: 2011 CAISO Peak Day Capacity Factors by Technology and PA—GT



**Figure A-32: 2011 CAISO Peak Day Capacity Factors by Technology and PA—ICE-N**



**Figure A-33: 2011 CAISO Peak Day Capacity Factors by Technology and PA—MT-N**

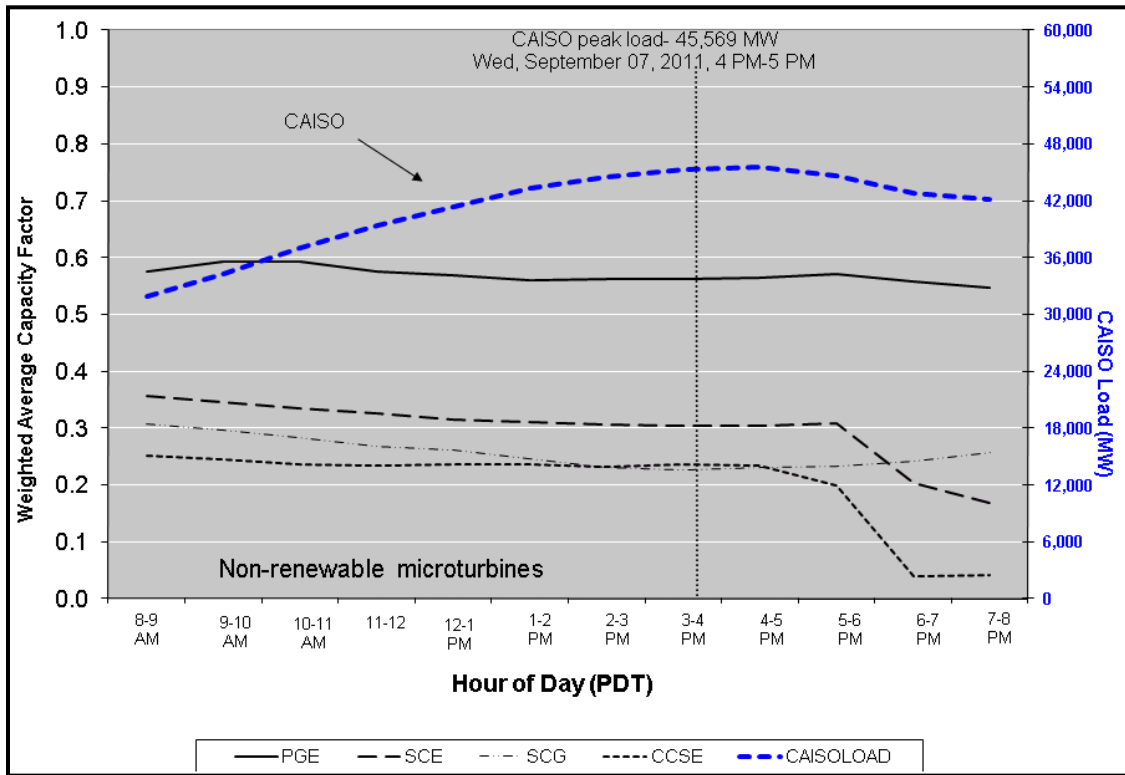


Figure A-34, Figure A-35, and Figure A-36 plot profiles of hourly weighted average CFs for GT, ICE-N, and MT-N projects directly feeding the electric utilities on the dates of their respective annual peak hours. Projects administered by the PA associated with the electric utility but not feeding directly into its distribution system are not included in these results. The plots also indicate the date and hour and value of the peak load for the electric utility.

Figure A-34: 2011 IOU Peak Day Capacity Factors by Technology—PG&E

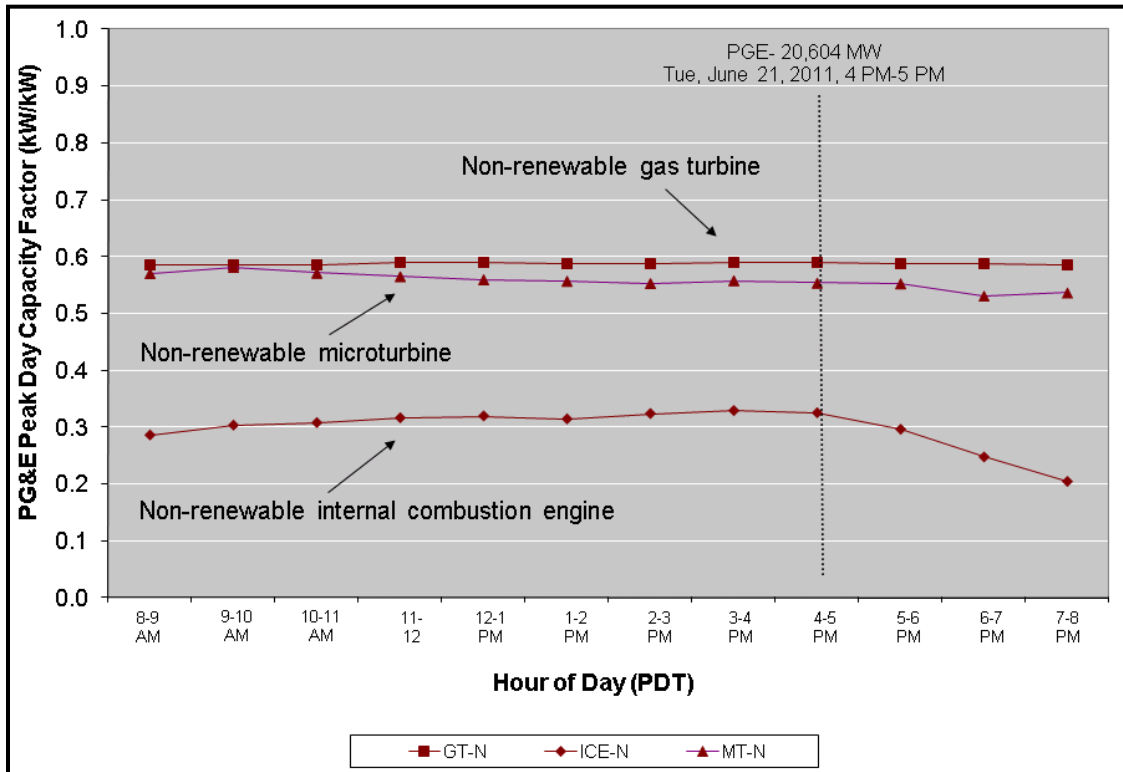


Figure A-35: 2011 IOU Peak Day Capacity Factors by Technology—SCE

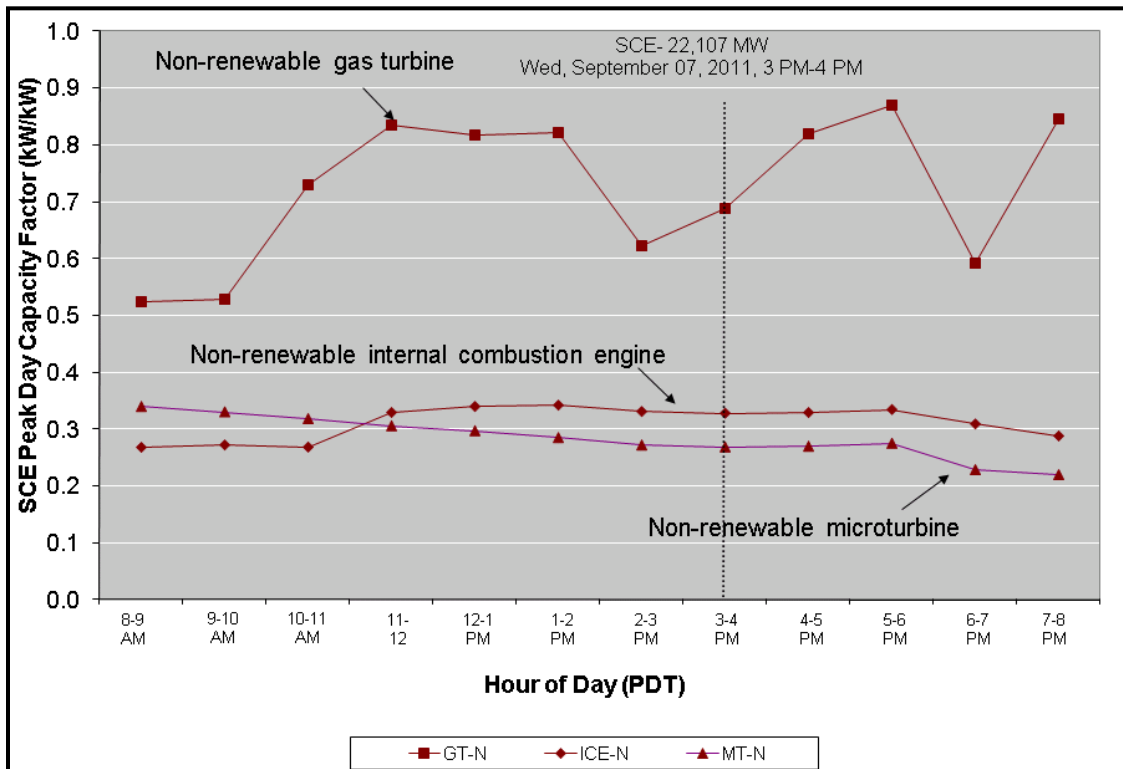
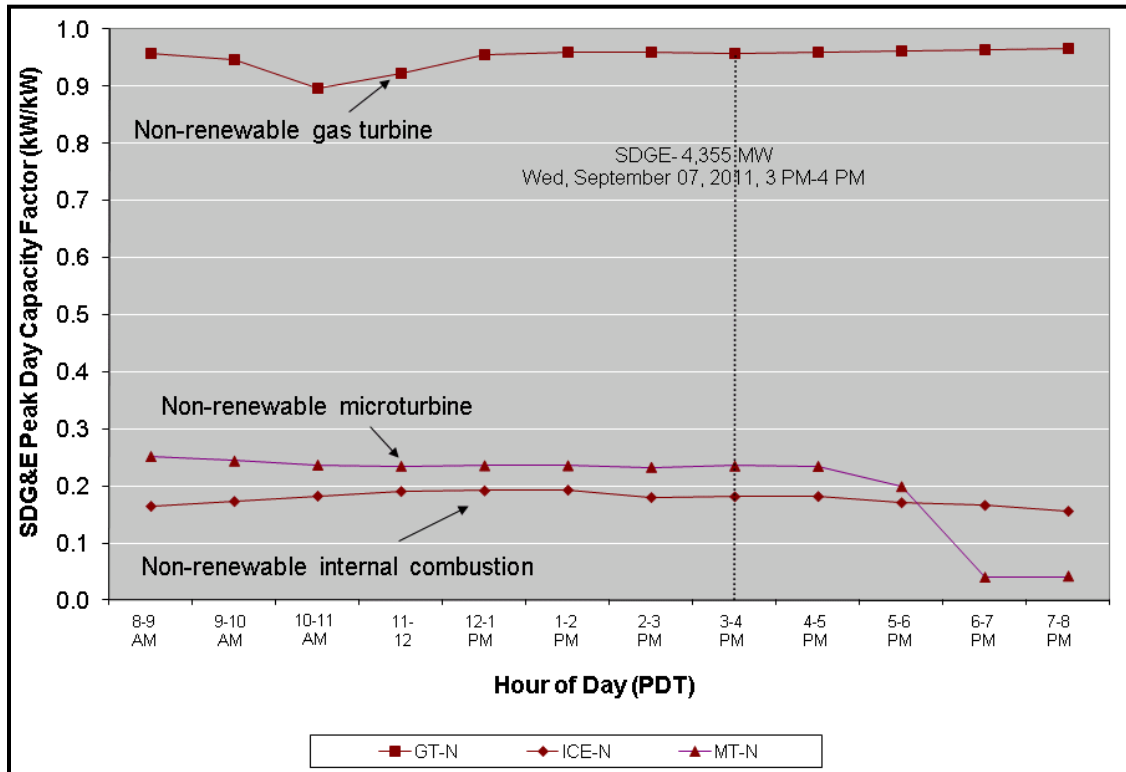


Figure A-36: 2011 IOU Peak Day Capacity Factors by Technology—SDG&E



#### A.4 Annual Trends

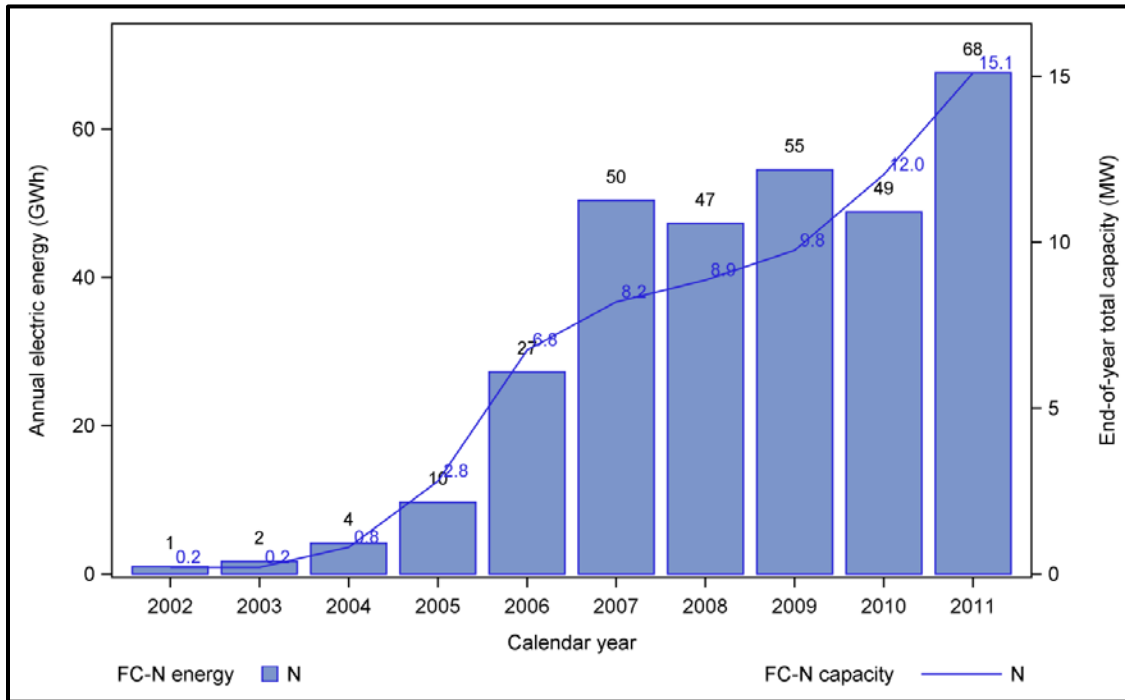
This section provides data plots of annual trends observed for the different SGIP technologies through the end of 2011. The trends include calendar year as well as age time series.

Plots from this section are included in Section 4 for select technologies. Section 4 contains thorough descriptions of plot contents that apply to all technologies shown here. See Section 4 for those descriptions.



**A.4.1 Growth in Capacity and Annual Impacts by Year**

**Figure A-37: FC-N Capacity and Annual Impacts by Year**



**Figure A-38: FC-R Capacity and Annual Impacts by Year**

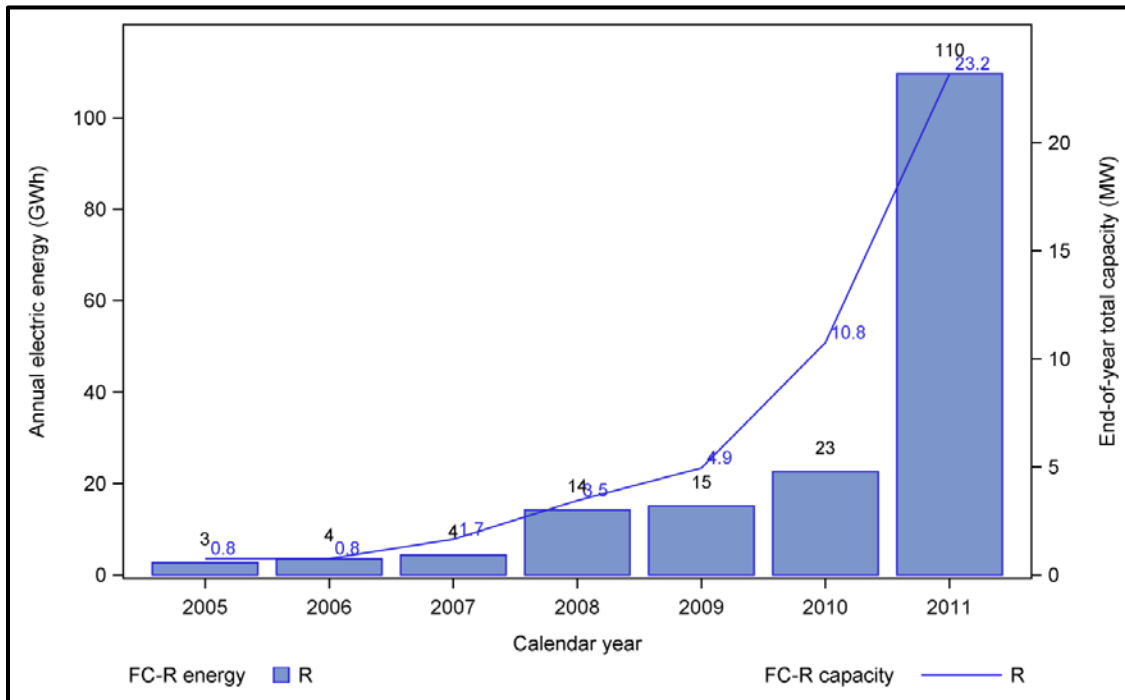


Figure A-39: ICE-N Capacity and Annual Impacts by Year

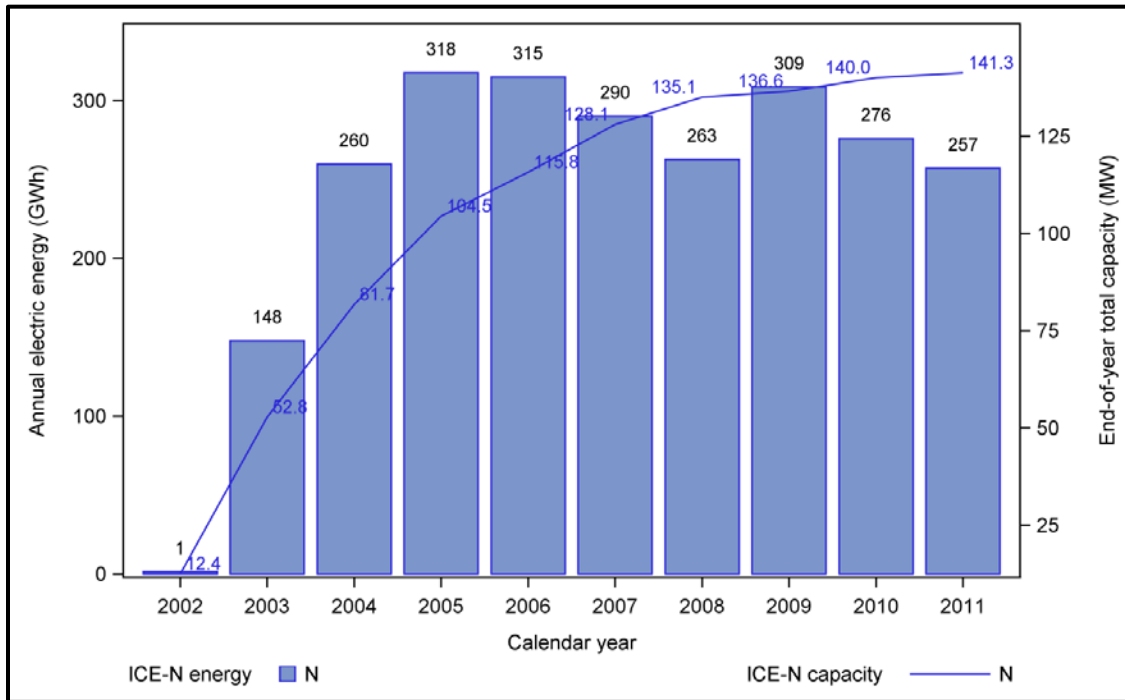


Figure A-40: ICE-R Capacity and Annual Impacts by Year

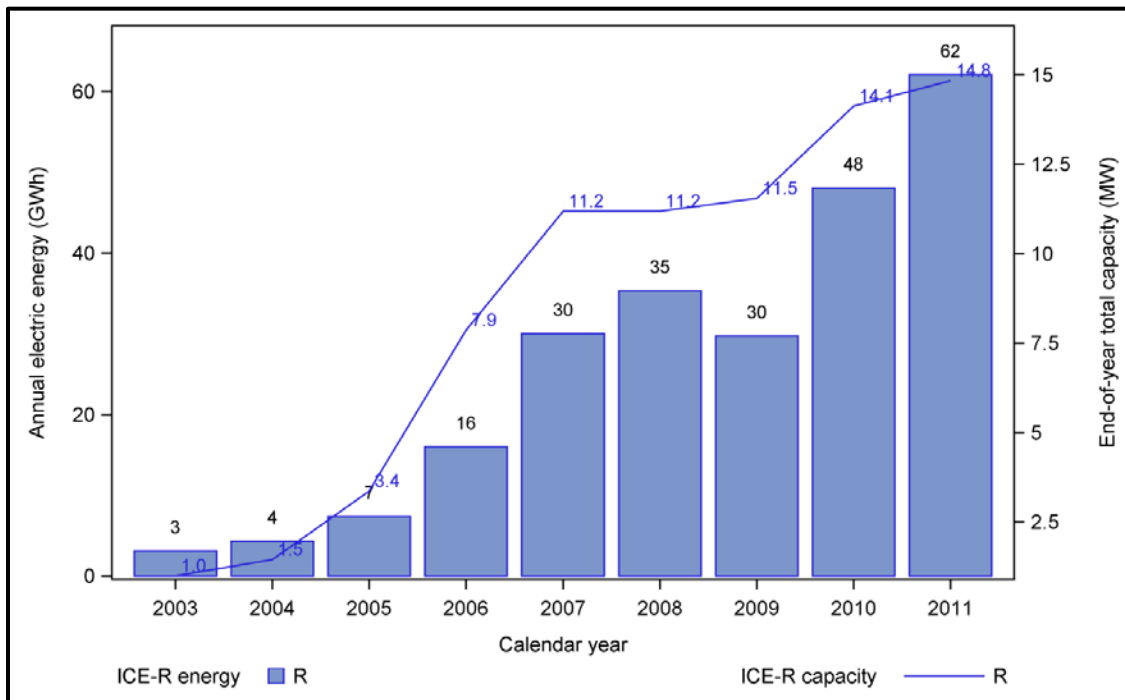


Figure A-41: GT Capacity and Annual Impacts by Year

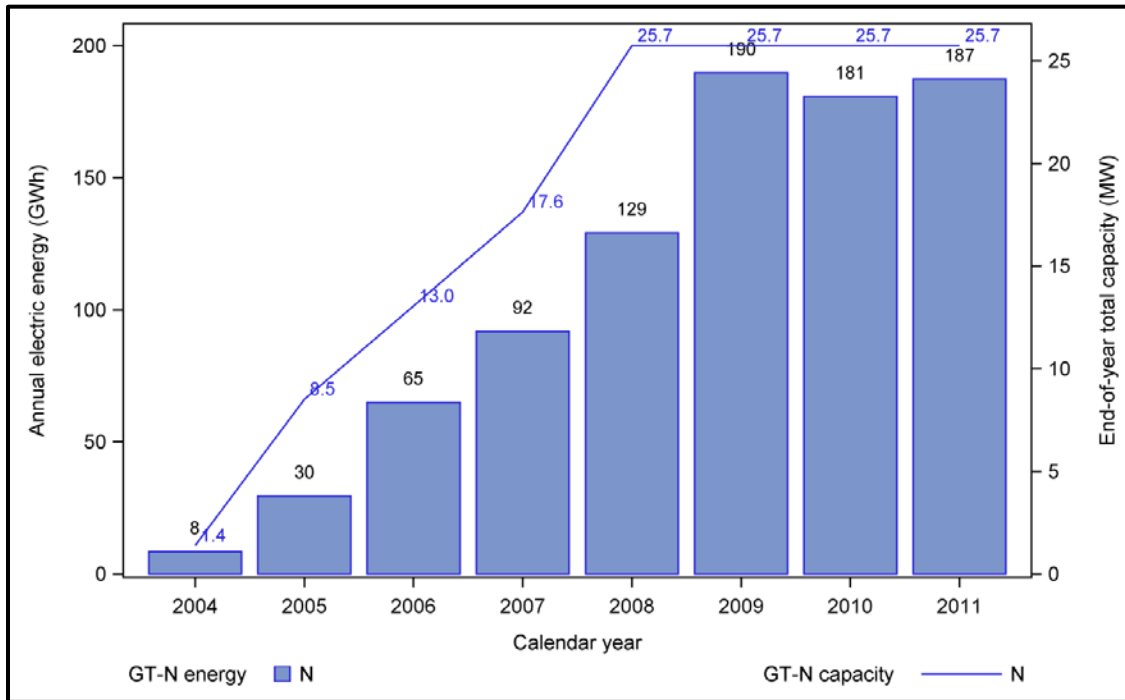


Figure A-42: MT-N Capacity and Annual Impacts by Year

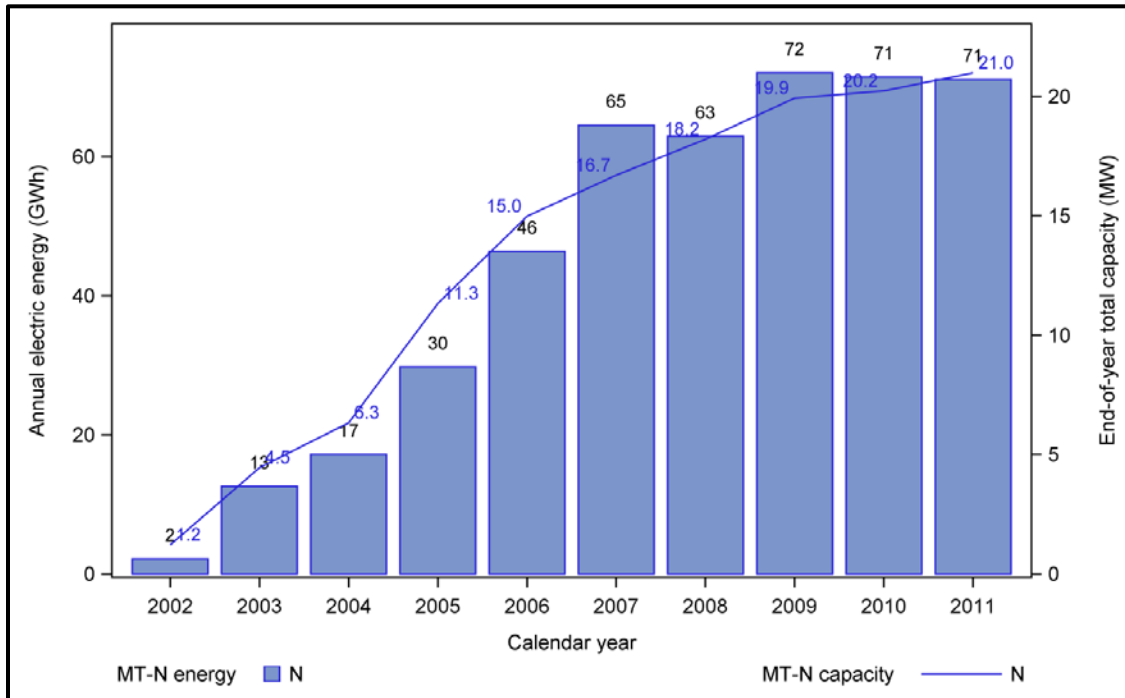
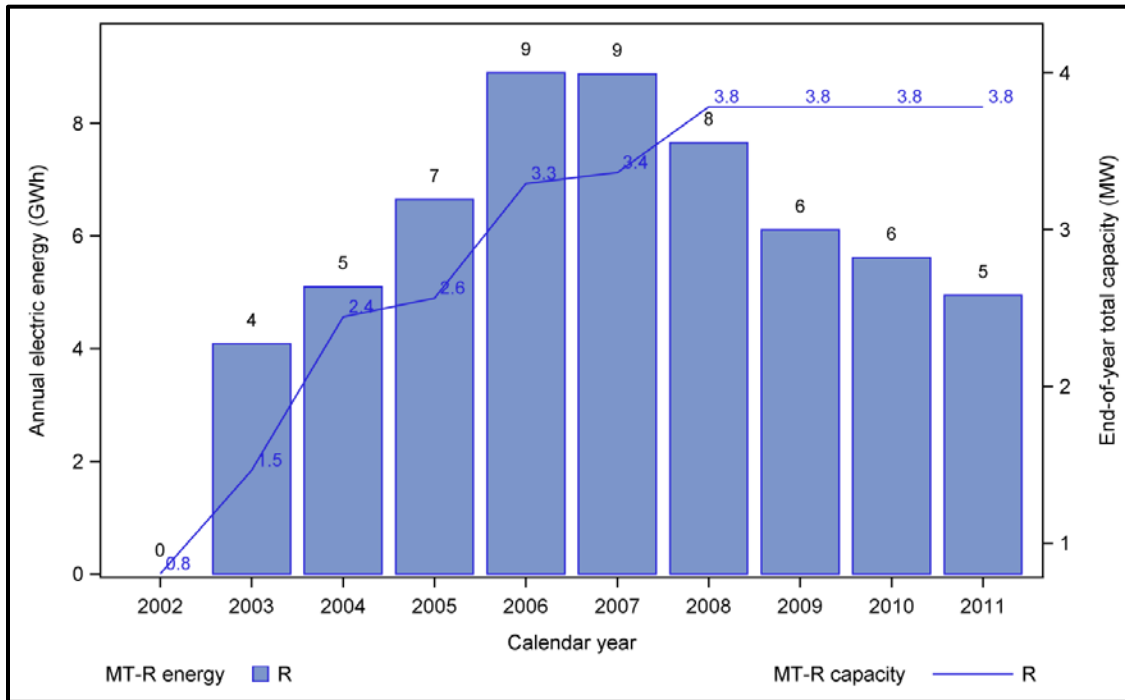


Figure A-43: MT-R Capacity and Annual Impacts by Year



**Annual Capacity Factor and Off-line Trends with Age**

Figure A-44: FC-N Annual Capacity Factor and Off-line by Age

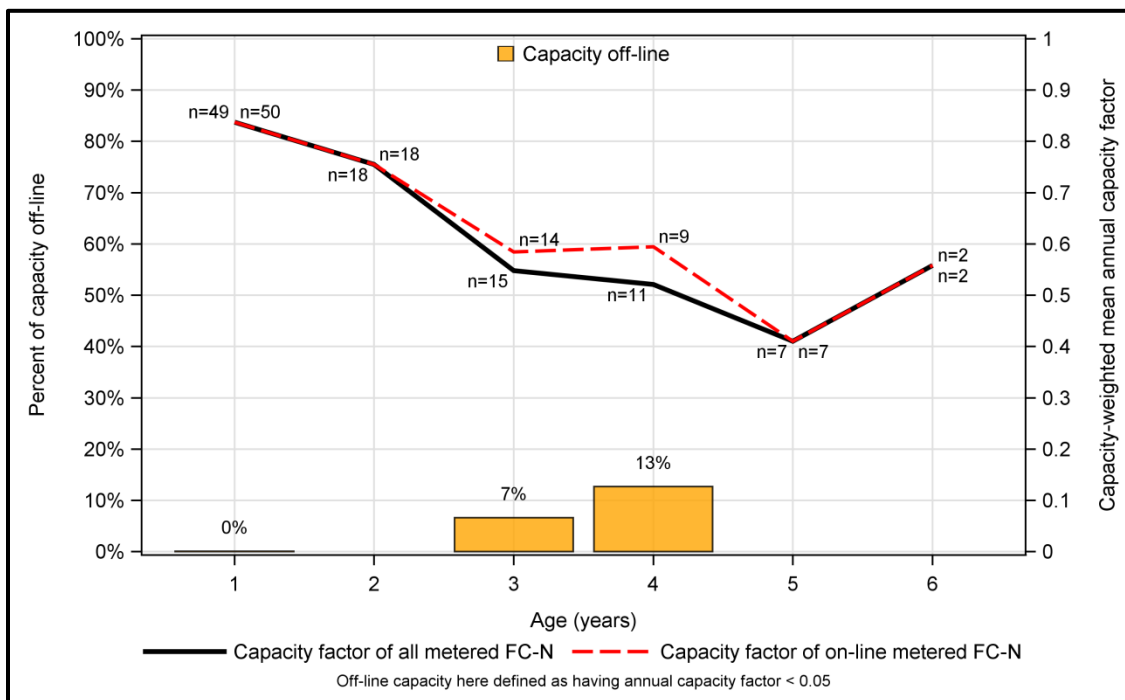


Figure A-45: FC-R Annual Capacity Factor and Off-line by Age

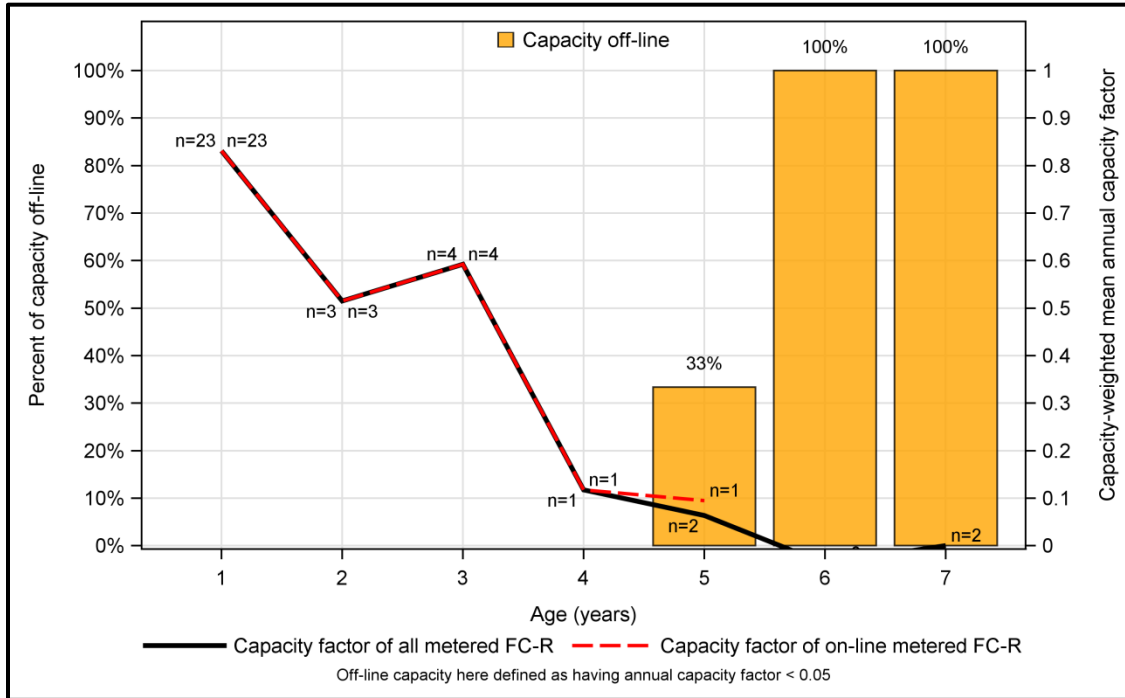


Figure A-46: GT- Annual Capacity Factor and Off-line by Age

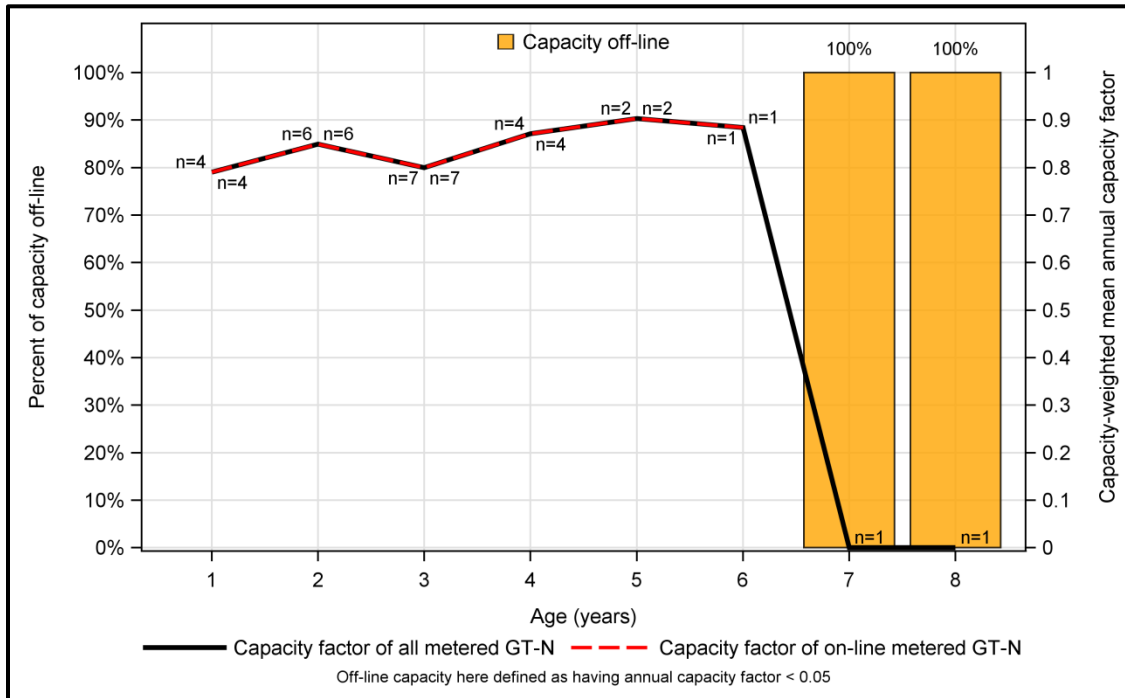


Figure A-47: ICE-N Annual Capacity Factor and Off-line by Age

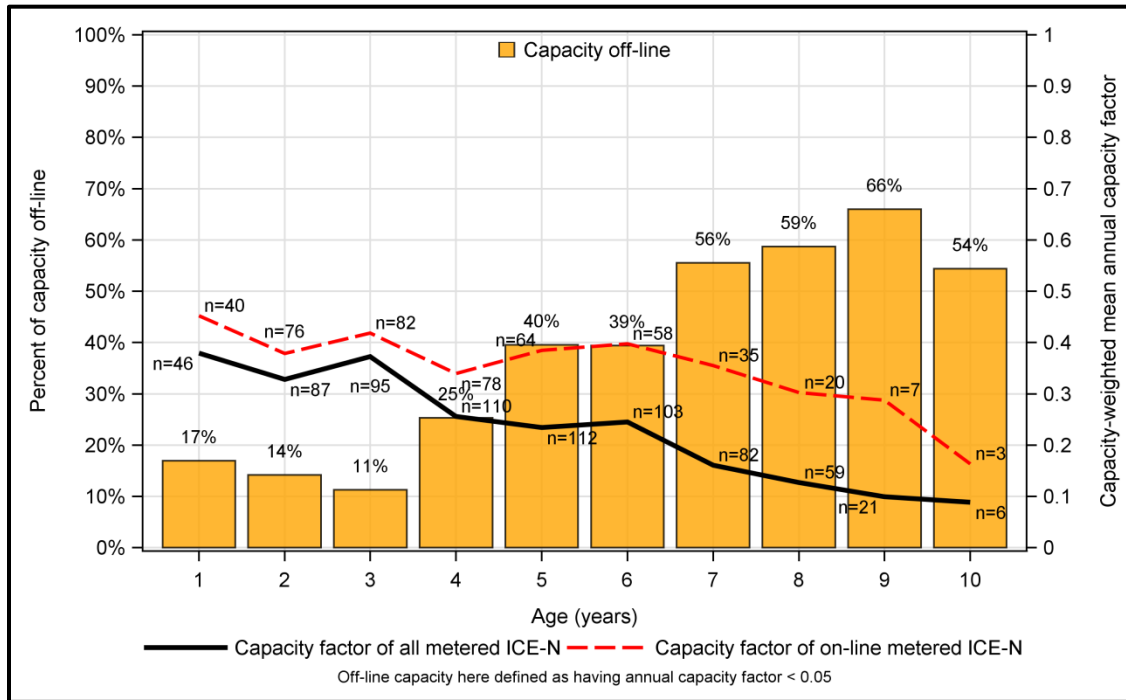


Figure A-48: ICE-R Annual Capacity Factor and Off-line by Age

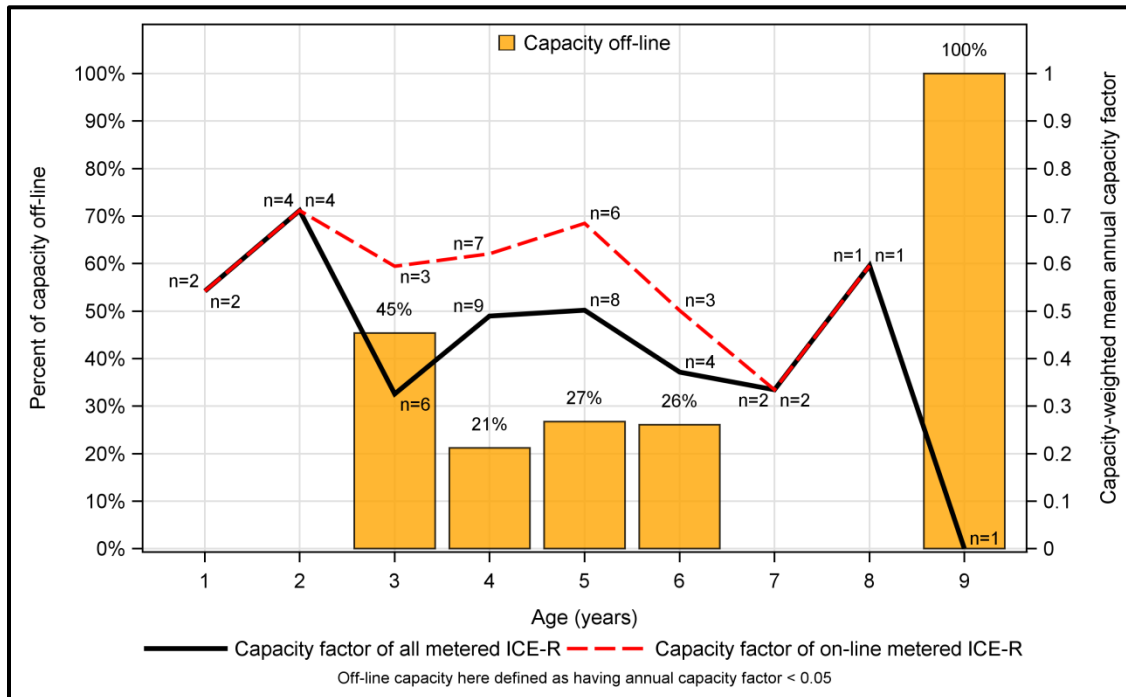


Figure A-49: MT-N Annual Capacity Factor and Off-line by Age

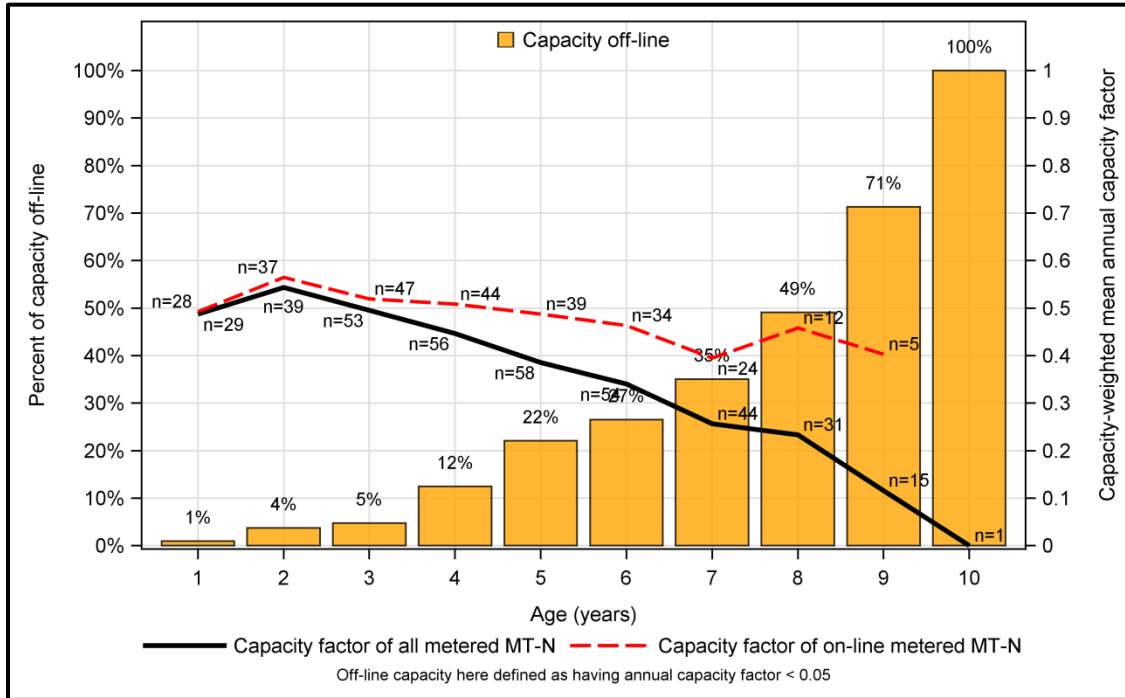
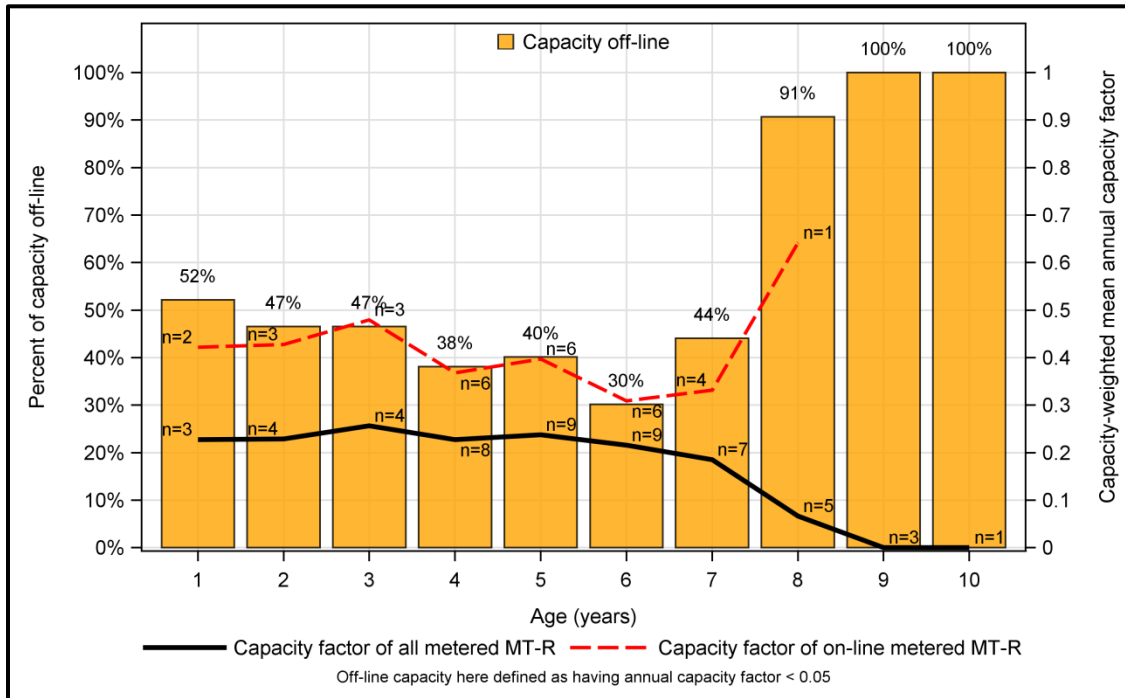
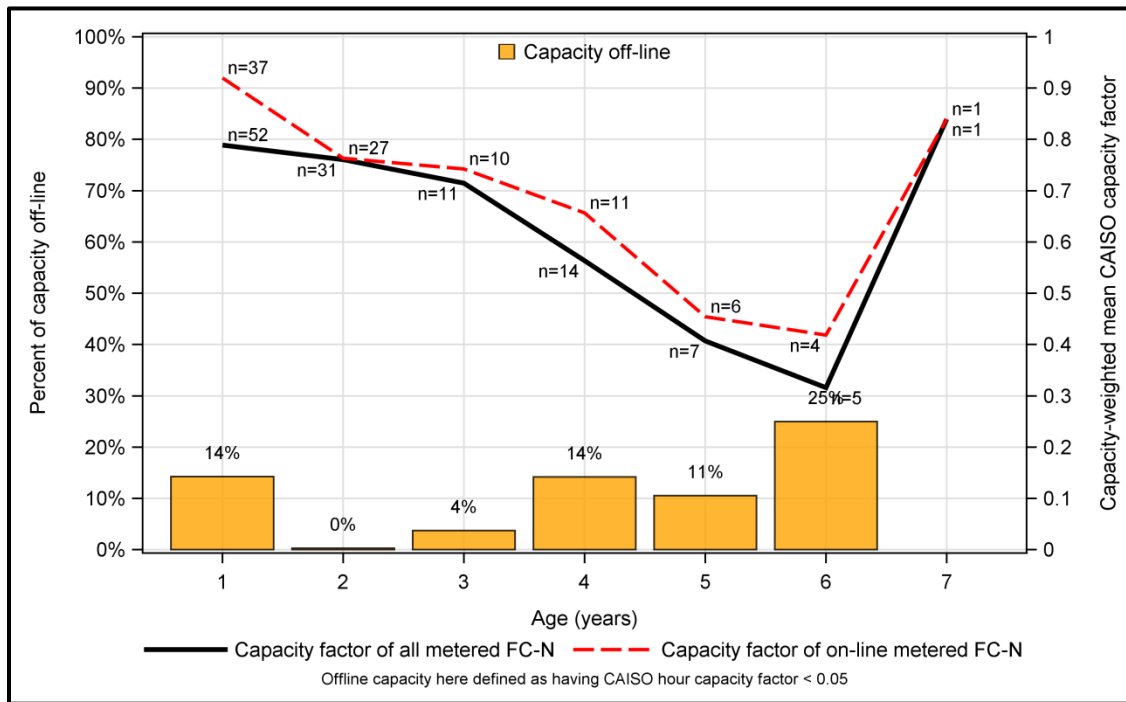


Figure A-50: MT-R Annual Capacity Factor and Off-line by Age



**CAISO Peak Hour Capacity Factor and Off-line Trends with Age**

**Figure A-51: FC-N CAISO Peak Hour Capacity Factor and Off-line by Age**



**Figure A-52: FC-R CAISO Peak Hour Capacity Factor and Off-line by Age**

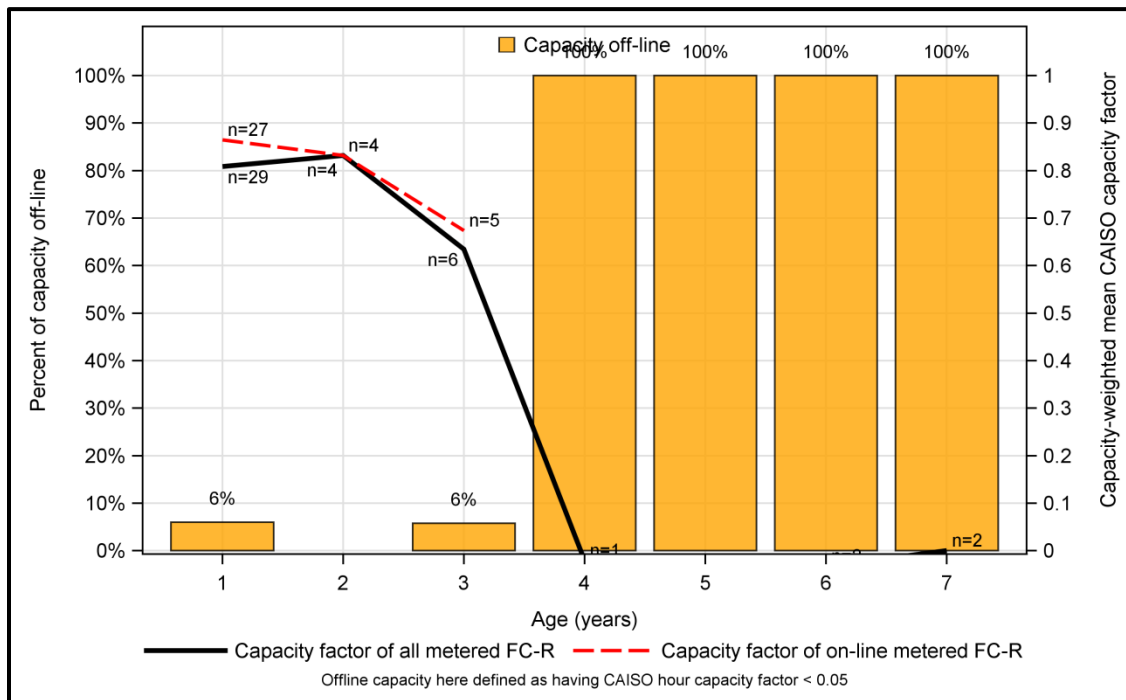




Figure A-53: GT CAISO Peak Hour Capacity Factor and Off-line by Age

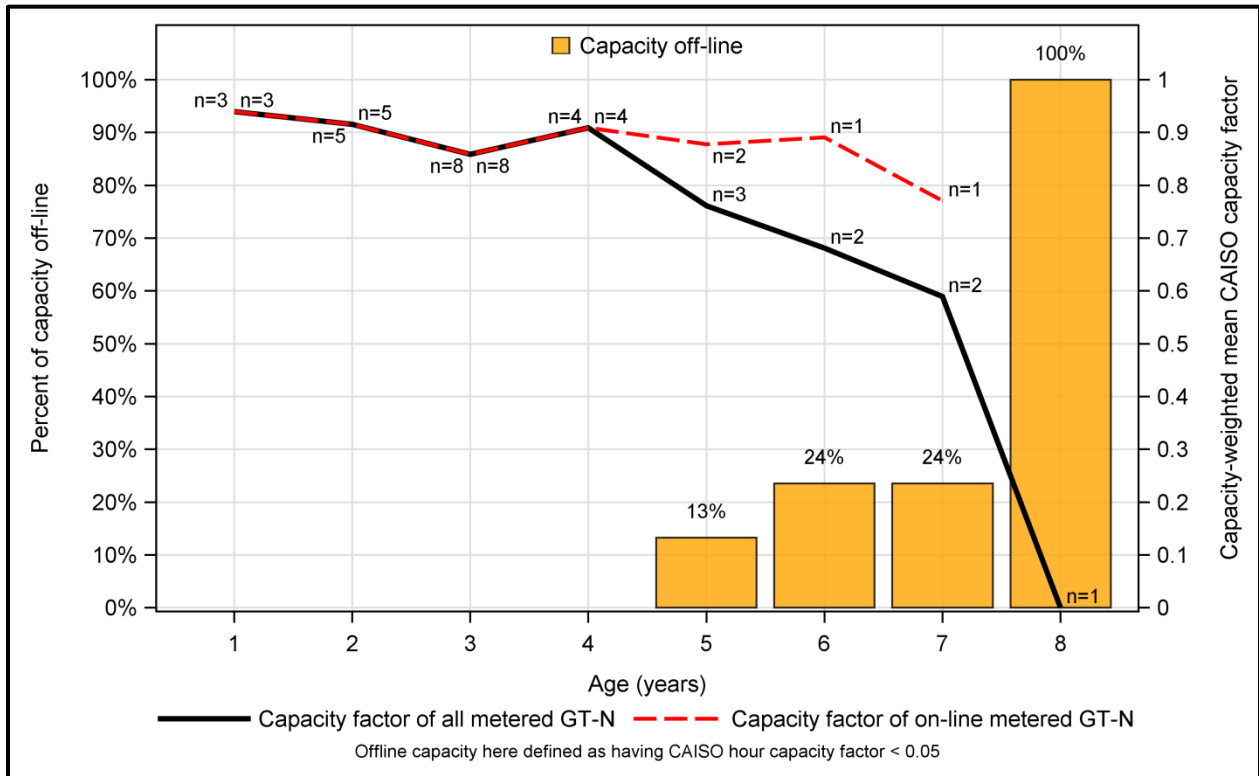


Figure A-54: ICE-N CAISO Peak Hour Capacity Factor and Off-line by Age

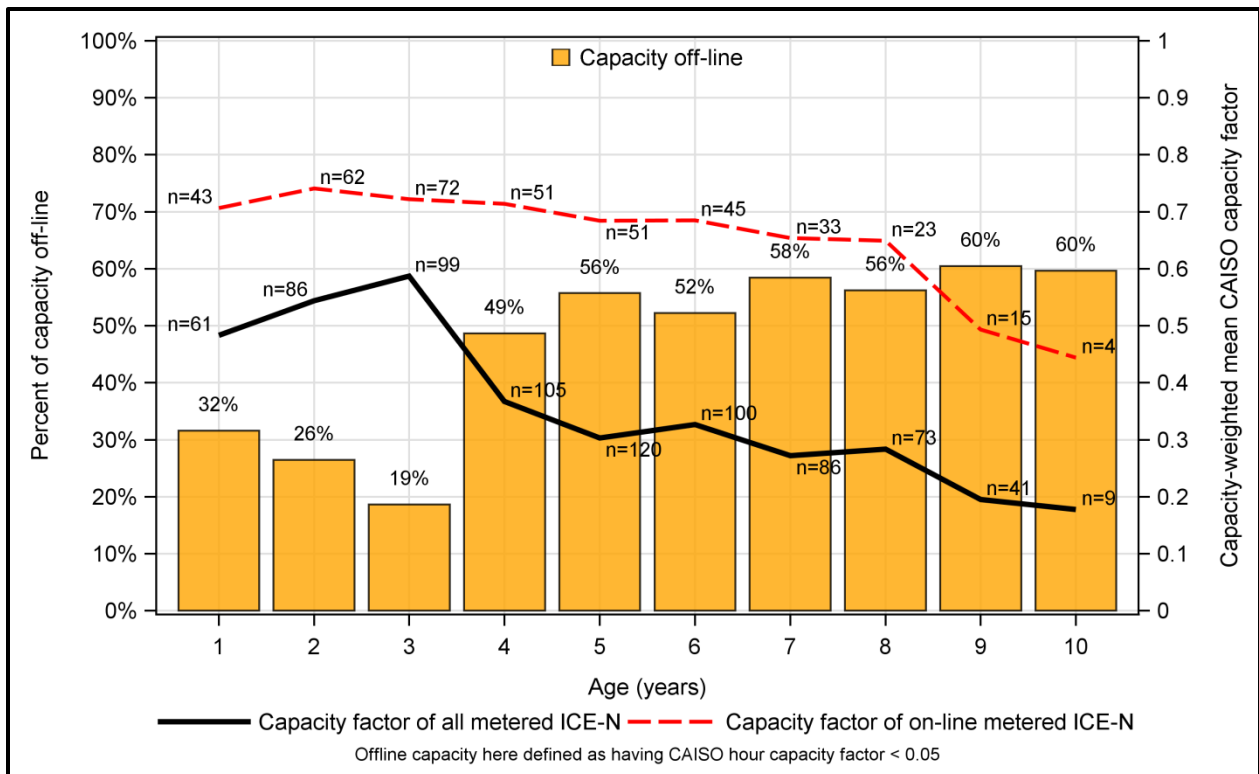


Figure A-55: ICE-R CAISO Peak Hour Capacity Factor and Off-line by Age

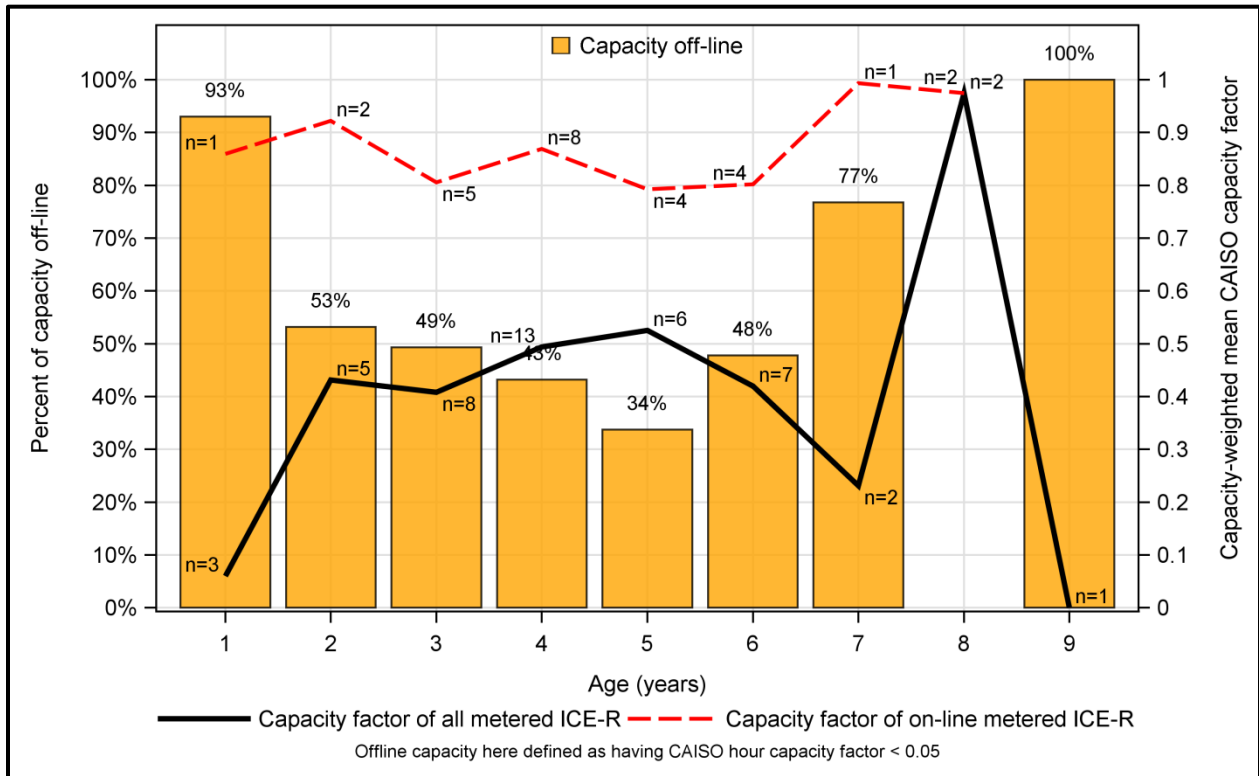


Figure A-56: MT-N CAISO Peak Hour Capacity Factor and Off-line by Age

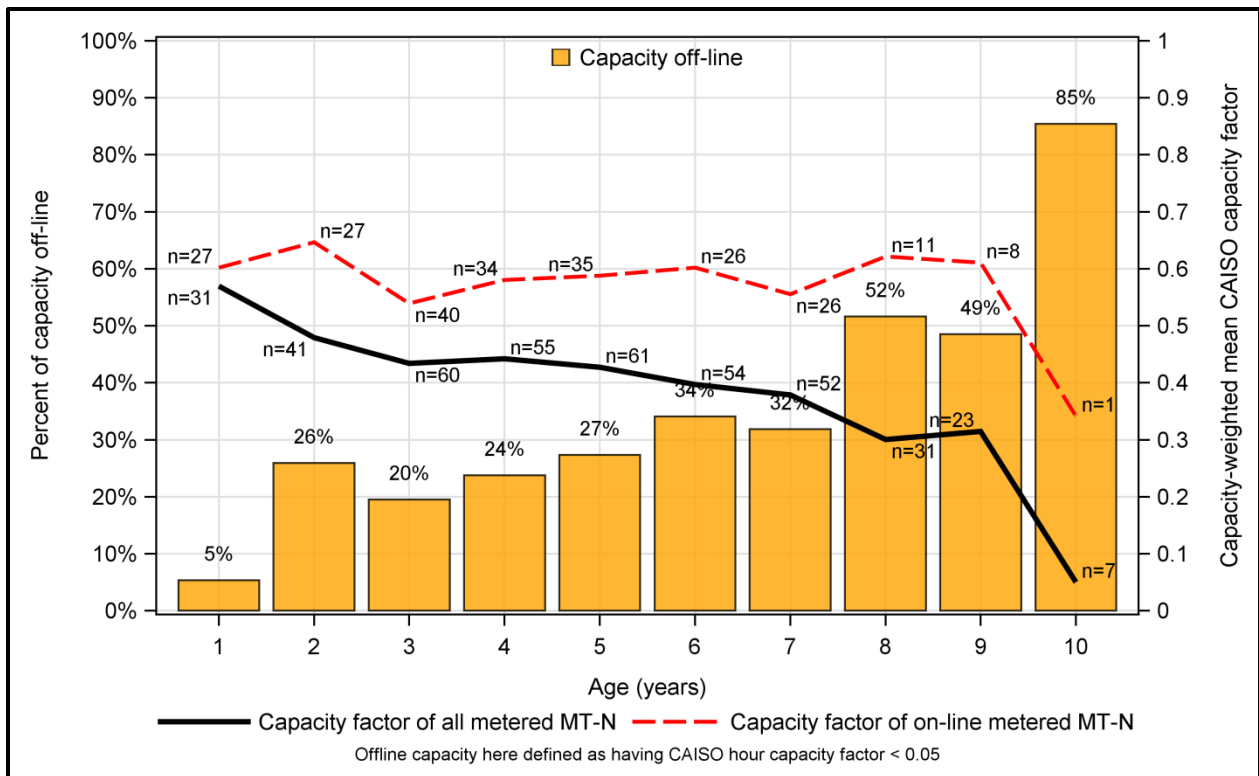
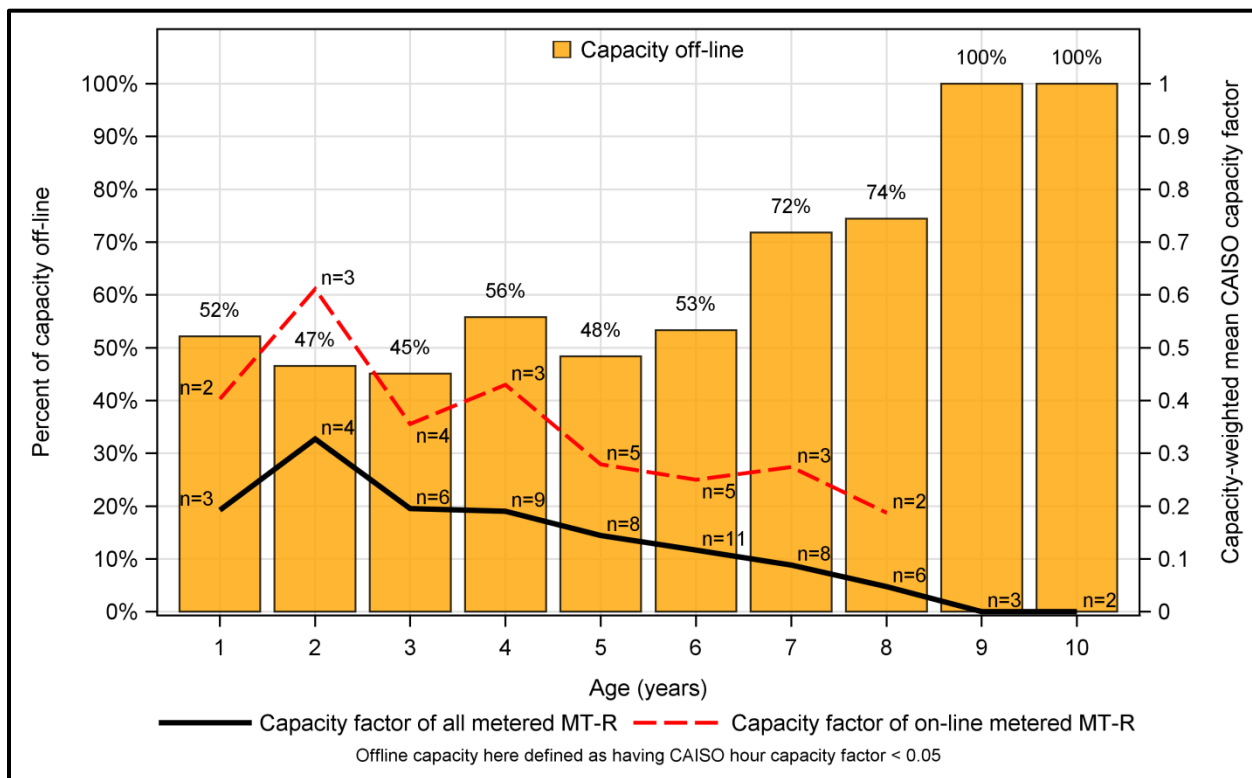
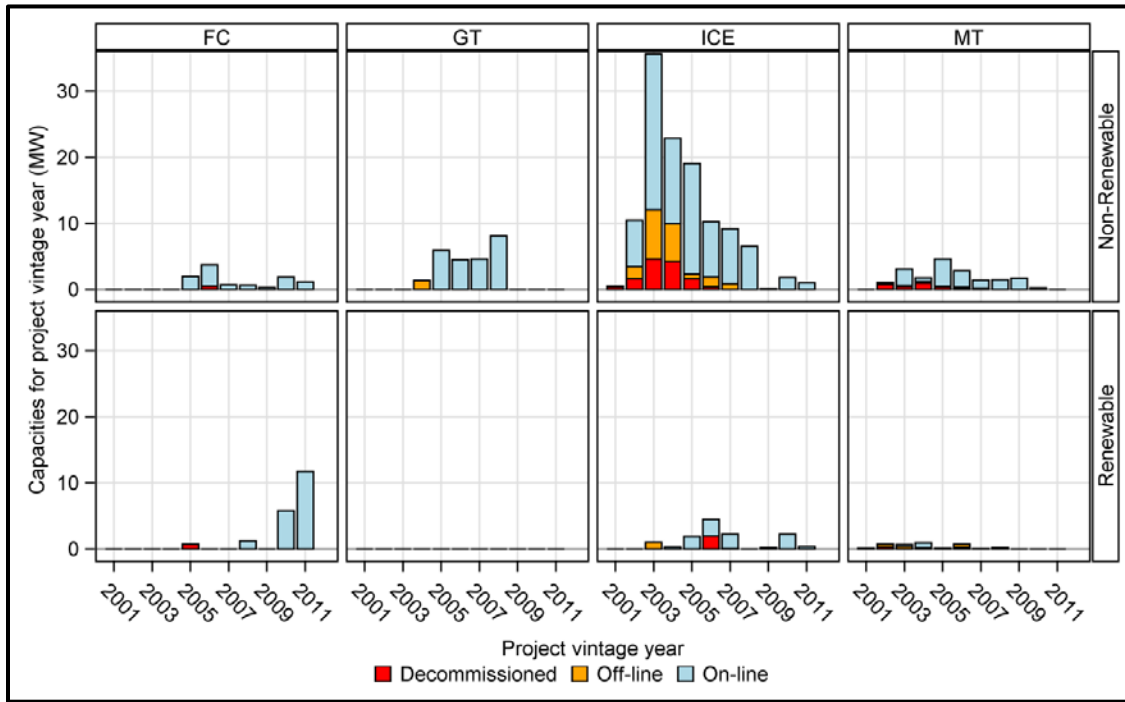


Figure A-57: MT-R CAISO Peak Hour Capacity Factor and Off-line by Age

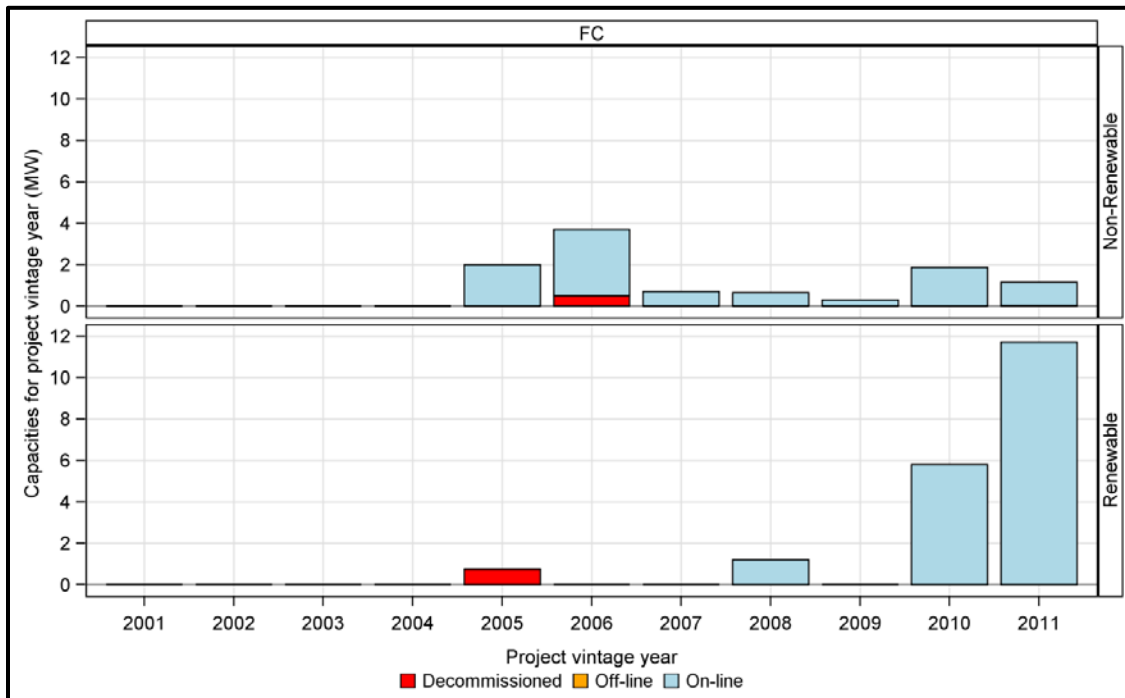


**2011 Decommissioned and Off-line Capacities by Project Vintage**

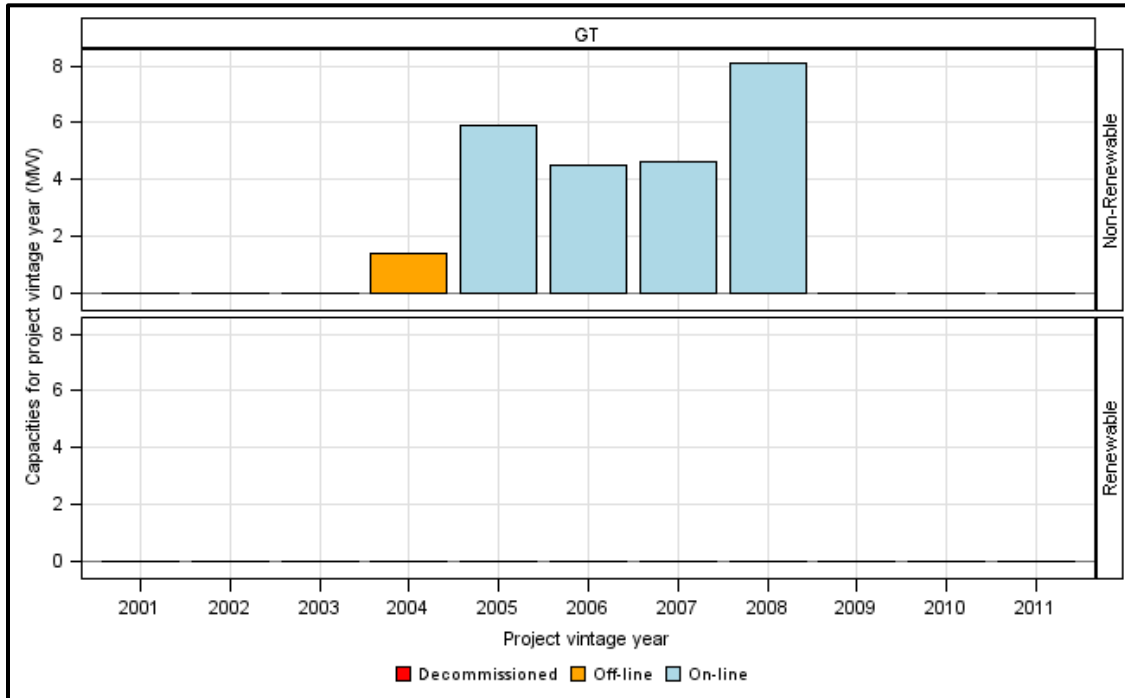
**Figure A-58: 2011 Capacities Decommissioned, Off-line, and On-line by Vintage**



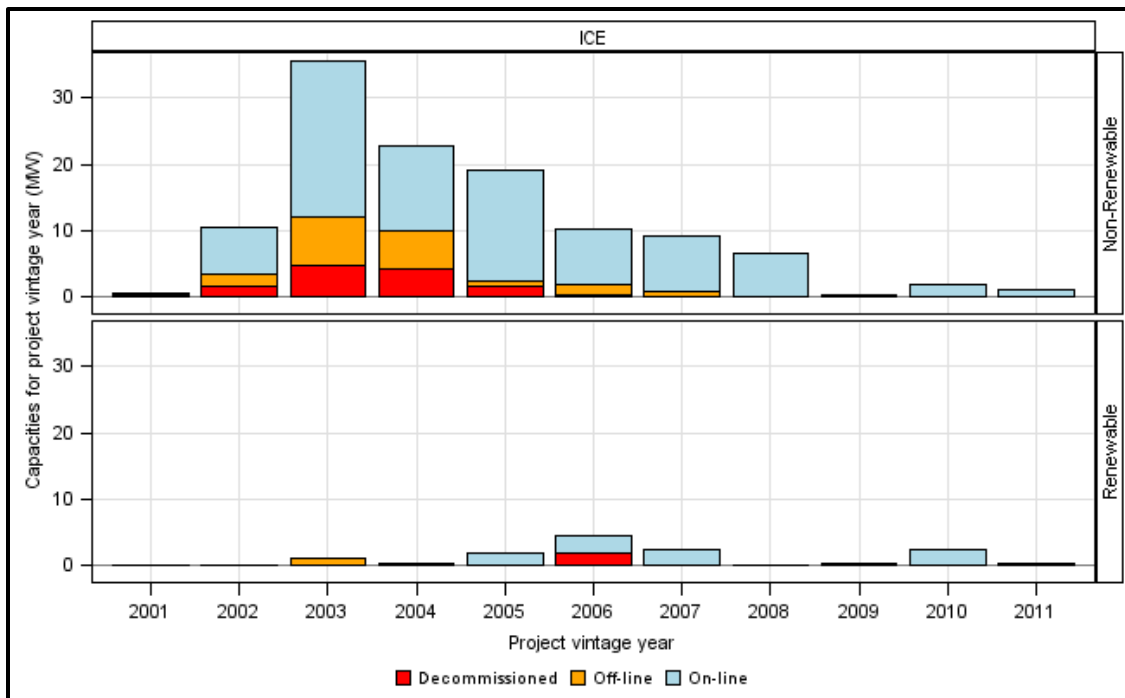
**Figure A-59: 2011 FC Capacities Decommissioned, Off-line, and On-line by Vintage**



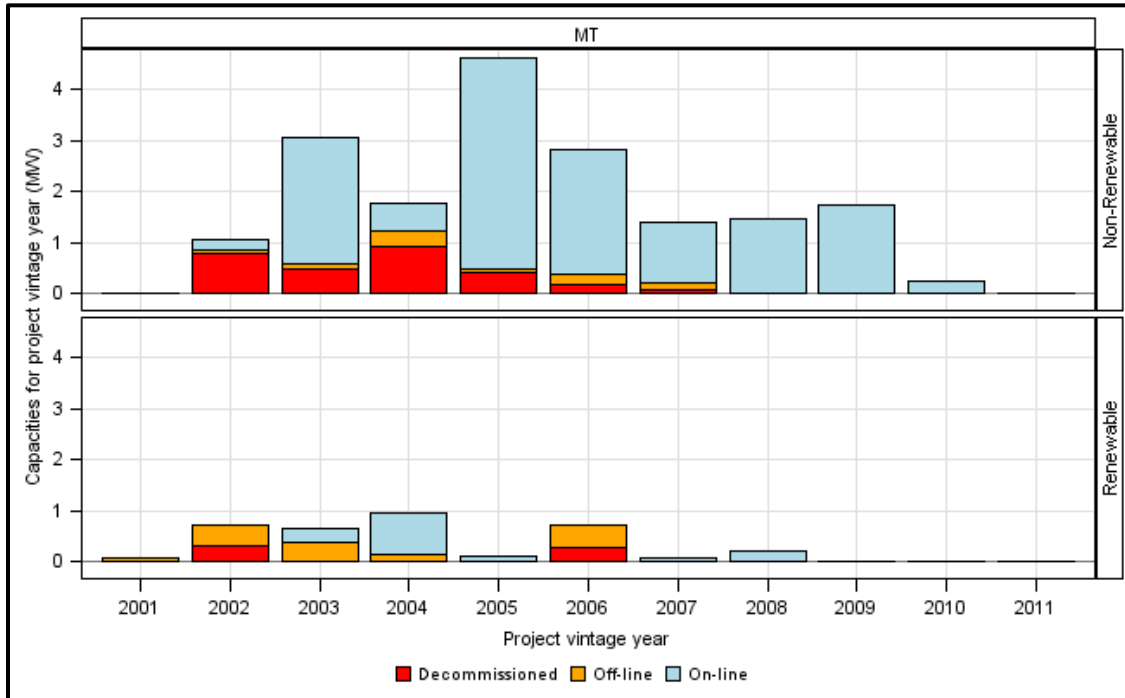
**Figure A-60: 2011 GT Capacities Decommissioned, Off-line, and On-line by Vintage**



**Figure A-61: 2011 ICE Capacities Decommissioned, Off-line, and On-line by Vintage**



**Figure A-62: 2011 MT Capacities Decommissioned, Off-line, and On-line by Vintage**



# Appendix B

## Greenhouse Gas Emissions Impacts Methodology

---

This appendix describes the methodology used to estimate the impacts on greenhouse gas (GHG) emissions from the operation of SGIP systems on-line during 2011. GHG emissions considered in this analysis are limited to carbon dioxide (CO<sub>2</sub>) and methane (CH<sub>4</sub>), as these are the two primary pollutants whose emissions are potentially affected by the operation of SGIP systems. The operation of wind turbines and non-renewable fuel cells, microturbines, gas turbines and internal combustion (IC) engines directly affect CO<sub>2</sub> emissions. Fuel cells, microturbines, and IC engines powered by biogas resources can directly affect both CH<sub>4</sub> and CO<sub>2</sub> emissions. GHG emissions are reported in units of metric tons of CO<sub>2</sub> equivalents (MTCDE) for easy comparison.<sup>1</sup> One metric ton of emitted CH<sub>4</sub> is equivalent to 21 MTCDE.

### B.1 Overview

GHG emission impacts are calculated for each SGIP site and then summed by SGIP technology. Emission impacts are calculated as the difference between the GHG emissions produced by the rebated DG system and the “baseline” GHG emissions. Baseline GHG emissions are those that would have occurred in the absence of the SGIP facility. SGIP generators displace baseline GHG emissions by satisfying facility electric loads at the site as well as heating/cooling loads, in some cases. In the case of SGIP DG systems powered by biogas, the SGIP facility may reduce emissions of CH<sub>4</sub> that would have otherwise been released to the atmosphere. Each component of the GHG impacts calculations is described below along with the variable name used in equations presented later:

- **SGIP System CO<sub>2</sub> Emissions (*SgipGHG*):** The operation of renewable and non-renewable-fueled DG systems (besides PV and wind) emits CO<sub>2</sub> as a result of combustion of the fuel powering the system. Emissions of CO<sub>2</sub> from SGIP DG systems are estimated based on the hour-by-hour electricity generated from SGIP facilities throughout the 2011 year.

---

<sup>1</sup> CO<sub>2</sub> equivalent is a metric measure used to compare the emissions of various GHG based upon their global warming potential (GWP). The CO<sub>2</sub> equivalent for a gas is derived by multiplying the tons of the gas by the associated GWP. One metric ton is equal to 2,205 pounds.  
OECD Glossary of Statistical Terms: <http://stats.oecd.org/glossary/detail.asp?ID=285>

- Electric Power Plant CO<sub>2</sub> Emissions (*BasePpEngo*): When in operation, power generated by all SGIP technologies directly displaces electricity that would have been generated from a central station power plant in the absence of the SGIP to satisfy the site's electrical loads.<sup>2</sup> As a result, SGIP projects displace the accompanying CO<sub>2</sub> emissions that these central station power plants would have released to the atmosphere. The CO<sub>2</sub> emissions from these conventional power plants are estimated on an hour-by-hour basis over all 8,760 hours of 2011.<sup>3</sup> The estimates of electric power plant CO<sub>2</sub> emissions are based on a methodology developed by Energy and Environmental Economics, Inc. (E3) and made publicly available on its website as part of its avoided cost calculator.<sup>4</sup>
- CO<sub>2</sub> Emissions Associated with Cooling Services (*BasePpChiller*): SGIP systems delivering recovered heat to absorption chillers are assumed to reduce the need to operate on-site electric chillers using electricity purchased from the utility company. Baseline CO<sub>2</sub> emissions associated with electric chiller operations are calculated based on estimates of hourly chiller operations and on the electric power plant CO<sub>2</sub> emissions methodology described previously.
- CO<sub>2</sub> Emissions Associated with Heating Services (*BaseBlr*): Waste heat is recovered from the operation of cogeneration systems. The recovered heat may displace natural gas that would have been used to fuel boilers to satisfy the heating loads at the site in the absence of the SGIP. This displaces accompanying CO<sub>2</sub> emissions from the boiler's combustion process. Since virtually all carbon in natural gas is converted to CO<sub>2</sub> during combustion, the amount of CH<sub>4</sub> released from incomplete combustion is considered insignificant and is not included in this baseline component.
- CO<sub>2</sub> Emissions from Biogas Treatment (*BaseBio*): Biogas-powered SGIP facilities capture and use CH<sub>4</sub> that otherwise may have been emitted to the atmosphere (vented), or captured and burned, producing CO<sub>2</sub> (flared). In the PY07 and PY08 impact reports, in absence of the SGIP, all landfill gas facilities were assumed to have

---

<sup>2</sup> In this analysis, GHG emissions from SGIP facilities are compared only to GHG emissions from utility power generation that could be subject to economic dispatch (i.e., central station natural gas-fired combined cycle facilities and simple cycle gas turbine peaking plants). It is assumed that operation of SGIP facilities have no impact on electricity generated from utility facilities not subject to economic dispatch. Consequently, comparison of SGIP facilities to nuclear or hydroelectric facilities is not made as neither of these facilities is subject to dispatch.

<sup>3</sup> Consequently, during those hours when a SGIP facility is not in operation, displacement of CO<sub>2</sub> emissions from central station power plants is equal to zero.

<sup>4</sup> Energy and Environmental Economics. *Methodology and Forecast of Long Term Avoided Costs for the Evaluation of California Energy Efficiency Programs*. For the California Public Utilities Commission. October 25, 2004. [http://www.ethree.com/CPUC/E3\\_Avoided\\_Costs\\_Final.pdf](http://www.ethree.com/CPUC/E3_Avoided_Costs_Final.pdf)



captured and flared the CH<sub>4</sub>; all dairies were assumed to have vented the CH<sub>4</sub>; and other digesters were assumed to have vented digester gas if under 150 kW of rebated capacity and flared otherwise. In PY09-PY11 reports, all facilities except dairies are assumed to capture and flare CH<sub>4</sub>. Flaring was assumed to have the same degree of combustion completion as SGIP prime movers (e.g., IC engines, microturbines, fuel cells).

GHG emissions impacts were calculated as:

$$\Delta GHG_{ih} = SgipGHG_{ih} - (BasePpEngo_{ih} + BasePpChiller_{ih} + BaseBlr_{ih} + BaseBio_{ih})$$

where:

$\Delta GHG_{ih}$  is the change in GHG emissions attributable to the SGIP for participant  $i$  for hour  $h$ .

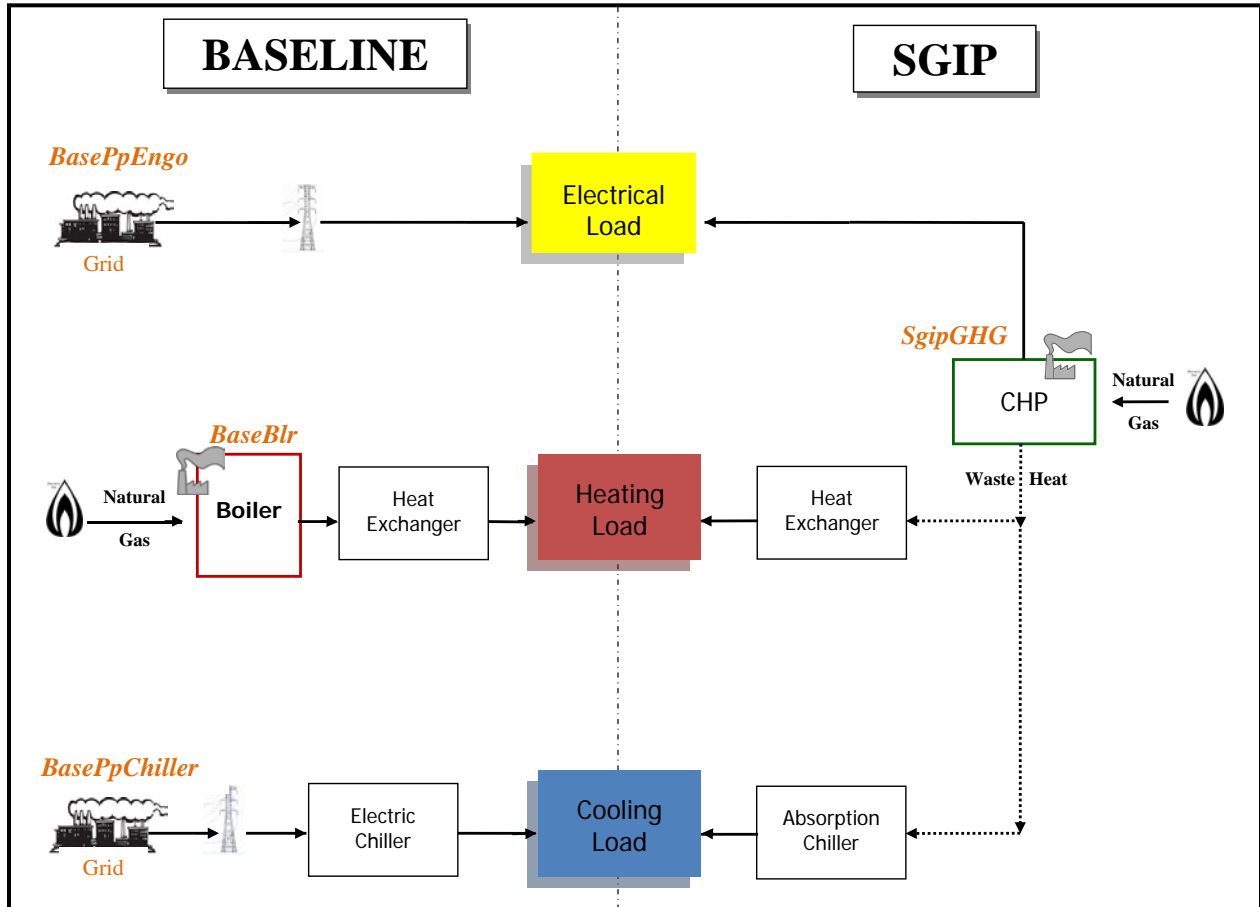
Units: MTCDE/hr

Therefore, negative GHG emissions impacts ( $\Delta GHG$ ) indicate a reduction in GHG emissions. Not all SGIP sites include all of the above variables. Inclusion is determined by the SGIP DG technology and fuel type and is discussed further in the sections B.2 and B.3. Section B.2 further describes GHG emissions from SGIP DG systems ( $SgipGHG$ ), as well as heating and cooling services associated with combined heat and power (CHP) systems. In Section B.3, baseline GHG emissions are described in detail.

The GHG impacts equation may also be depicted graphically as shown in Figure B-1 for non-renewable systems. Three boxes representing a host's electrical, heating, and cooling needs are drawn down the middle of the figure. The SGIP system is drawn on the right showing how each energy need is met by the DG system on-site. On the left, our assumptions of how these same needs would have been met in the absence of the program are shown as the baseline scenario. The energy delivered by the SGIP is assumed to be exactly the same as the energy delivered under the baseline scenario, but the way in which the energy is generated, and therefore the emissions associated with the delivery of the energy differ for each scenario.

For simplicity, the biogas component of the GHG impacts equation is not depicted graphically in Figure B-2. Instead, it is discussed in more detail in section B.3.3.

**Figure B-1: Graphical Depiction of GHG Impacts Equation for Non-Renewable Systems**



## B.2 SGIP System GHG Emissions

The following description of SGIP DG system operations covers two areas. The first area covers GHG emissions from electricity generated from rebated SGIP systems. The second area describes heating and cooling services provided by CHP SGIP systems. The amount of heating and cooling service estimated for CHP SGIP systems is used later in the analysis to estimate the baseline GHG emissions that would have resulted if conventional means (i.e., natural gas boiler, electric chiller) were used to provide those services. Because the baseline GHG emissions from heating and cooling services are estimated from the actual quantity of useful waste heat recovered from the SGIP system, the associated heating and cooling services are discussed here, rather than in Section B.3.

**B.2.1 Emissions from Rebated SGIP Systems**

Some SGIP sites emit CO<sub>2</sub>; this must be taken into account when calculating the GHG emission impacts for SGIP facilities. Wind SGIP sites do not emit CO<sub>2</sub>. CO<sub>2</sub> emission rates for the SGIP facilities that use gaseous fuel were calculated as:

$$(CO_2)_T \cong \left( \frac{3412 \text{ Btu}}{\text{kWh}} \right) \left( \frac{1}{EFF_T} \right) \left( \frac{\text{ft}^3 \text{ of } CH_4}{1000 \text{ Btu}} \right) \left( \frac{\text{lbmole of } CH_4}{360 \text{ ft}^3} \right) \left( \frac{\text{lbmole of } CO_2}{\text{lbmole of } CH_4} \right) \left( \frac{44 \text{ lbs of } CO_2}{\text{lbmole of } CO_2} \right)$$

where:

(CO<sub>2</sub>)<sub>T</sub> is the CO<sub>2</sub> emission rate for technology T.

Units:  $\frac{\text{lbs of } CO_2}{\text{kWh}}$

EFF<sub>T</sub> is the electrical efficiency of technology T.

Value: Value dependent on technology type

Technology Type	EFF <sub>T</sub>
Fuel Cell – CHP	0.384
Fuel Cell – Electric Only	0.464
Fuel Cell – PEM	0.362
Gas Turbine	0.319
IC Engine	0.309
Microturbine	0.230

Units: Dimensionless fractional efficiency

Basis: Lower heating value (LHV).

Metered data collected in 2011 from SGIP CHP systems

The technology-specific emission rates were calculated to account for CO<sub>2</sub> emissions released from SGIP systems. When multiplied by the electricity generated from these systems, the results represent hourly CO<sub>2</sub> emissions in pounds, which are then converted into metric tons, as shown in the equation below.

$$SgipGHG_{ih} = ((CO_2)_T \times engohr_{ih}) \times \left( \frac{\text{metric ton } CO_2}{2,205 \text{ lbs } CO_2} \right)$$

where:

$SgipGHG_{ih}$  is the CO<sub>2</sub> emitted for participant  $i$  during hour  $h$ .

Units: MTCDE/hr

$engohr_{ih}$  is the electrical output of the rebated SGIP system net of any parasitic losses.

Units: kWh

Basis: Metered data collected in 2011 from SGIP CHP systems

### ***B.2.2 Heating and Cooling Services Provided by SGIP CHP Systems***

The SGIP's CHP systems use heat recovered from prime movers to provide host facilities with heating and/or cooling services. The total quantity of heat recovered from each SGIP CHP system during each hour of the year is quantified via either direct measurement or estimation. The translation of these data into estimates of heating and/or cooling services provided is described below. This information is required later in the analysis to support the calculation of GHG emissions that would have occurred in the SGIP's absence, if these services had been provided by natural gas boilers and electric chillers.

Recovered heat from SGIP CHP systems serves heating and cooling loads. The heat data are allocated to heating, cooling, or both, depending on site-specific characteristics. As only total heat recovery data are available, the distribution between heating and cooling is assumed to be 50/50 if a SGIP facility uses recovered heat for both heating and cooling loads.

#### **Heating Services**

A heat exchanger is typically used to transfer waste heat recovered from SGIP CHP systems to building heating loads. The below equation represents the process by which the SGIP participant hourly heating services are calculated.

$$HEATING_{ih} = BOILER_i \times heathr_{ih} \times EffHx$$

where:

$HEATING_{ih}$  is the heating services provided by SGIP CHP participant  $i$  for hour  $h$ .

Units: kBtu

$BOILER_i$  is an allocation factor whose value depends on SGIP CHP system design (e.g., Heating Only, Heating & Cooling, or Cooling Only)

Value:

System Design	$BOILER_i$
Heating Only	1.0
Heating & Cooling	0.5
Cooling Only	0.0

Units: Dimensionless

Basis: System design as represented in Installation Verification Inspection Report

$heathr_{ih}$  is the quantity of useful heat recovered from the SGIP unit and used for heating services for SGIP CHP participant  $i$  for hour  $h$ .

Units: kBtu

Basis: Metering or ratio analysis depending on HEAT metering status

$EffHx$  is the efficiency of the SGIP CHP primary heat exchanger

Value: 0.9

Units: Dimensionless fractional efficiency

Basis: Assumed

**Cooling Services**

An absorption chiller is typically used to convert waste heat recovered from SGIP CHP systems into chilled water to serve building or process cooling loads.

$$COOLING_{ih} = CHILLER_i \times heathr_{ih} \times COP$$

where:

$COOLING_{ih}$  is the cooling services provided by SGIP CHP participant  $i$  for hour  $h$ .

Units: kBtu

$CHILLER_i$  is an allocation factor whose value depends on SGIP CHP system design (e.g., Heating Only, Heating & Cooling, or Cooling Only)

Value:

System Design	<i>CHILLER<sub>i</sub></i>
Heating Only	0.0
Heating & Cooling	0.5
Cooling Only	1.0

Units: Dimensionless

Basis: System design as represented in Installation Verification Inspection Report

*heathr<sub>ih</sub>* is the quantity of useful heat recovered for SGIP CHP participant *i* for hour *h*.

Units: kBtu

Basis: Metering or ratio analysis depending on HEAT metering status

*COP* is the efficiency of the absorption chiller using heat from the SGIP CHP system.

Value: 0.6

Units:  $\frac{kBTU_{out}}{kBTU_{in}}$

Basis: Assumed

### **B.3 Baseline GHG Emissions**

The following description of baseline operations covers three areas. First, the GHG emissions from electric power plants that would be required to operate more in the SGIP’s absence. These emissions would correspond to electricity generated by SGIP DG systems, as well as to electricity that would otherwise be consumed by electric chillers to satisfy cooling loads quantified in the previous section. Second, the GHG emissions from natural gas boilers that would have otherwise operated to satisfy heating load quantified in the previous section. Third, the GHG emissions corresponding to biogas that otherwise would have been flared (CO<sub>2</sub>) or vented directly into the atmosphere (CH<sub>4</sub>).

#### **B.3.1 Electric Power Plant GHG Emissions**

This section describes the methodology used to calculate CO<sub>2</sub> emissions from electric power plants that would have occurred to satisfy the electrical loads served by the SGIP DG system during PY11 in the absence of the program. The methodology involves combining emission rates (in metric tons of CO<sub>2</sub> per kWh of electricity generated) that are service territory- and hour-specific with information about the quantity of electricity either generated by SGIP DG systems or displaced by absorption chillers operating on heat recovered from CHP SGIP systems.

The service territory of the SGIP site is considered in the development of emission rates by accounting for whether the facility is located in PG&E's territory (northern California) or in SCE/SDG&E's territory (southern California). Variations in climate and electricity market conditions have an effect on the demand for electricity. This in turn affects the emission rates used to estimate the avoided CO<sub>2</sub> released by conventional power plants. Lastly, the date and time (hereafter referred to as 'hour') that electricity is generated affects the emission rates because the mix of high and low efficiency plants used differs throughout the day. The larger the proportion of low efficiency plants used to generate electricity, the greater the avoided CO<sub>2</sub> emission rate.

### **Electric Power Plant Hourly CO<sub>2</sub> Emission Rate**

The basic methodology used to formulate hourly CO<sub>2</sub> emission factors for this analysis is based on methodology developed by E3 and found in its avoided cost calculation workbook.<sup>5</sup> The E3 avoided cost calculation workbook assumes:

- The emissions of CO<sub>2</sub> released from a conventional power plant depend upon its heat rate, which in turn is dictated by the power plant's efficiency, and
- The mix of high and low efficiency plants in operation is determined by the price and demand for electricity at that time.

The premise for hourly CO<sub>2</sub> emission rates calculated in E3's workbook is that the marginal power plant relies on natural gas to generate electricity. Variations in the price of natural gas reflect the market demand conditions for electricity. As demand for electricity increases, all else being equal, the price of natural gas will rise. To meet the higher demand for electricity, utilities will have to rely more heavily on less efficient power plants once production capacity is reached at their relatively efficient plants. This means that during periods of higher electricity demand, there is increased reliance on lower efficiency plants, which in turn leads to a higher emission rate for CO<sub>2</sub>. In other words, one can expect an emission rate representing the release of CO<sub>2</sub> from the central grid to be higher during peak hours than during off-peak hours.

$BaseCO2EF_{ih}$  is the hourly CO<sub>2</sub> emission rate for northern or southern California,  $i$ , for every hour,  $h$ .

Source: E3 workbook

Units: metric tons of CO<sub>2</sub> per kWh

---

<sup>5</sup> The filename of the workbook that contains the data used to generate hour-specific emission factors for CO<sub>2</sub> is "cpucAvoided26.xls" and can be downloaded from [www.ethree.com/CPUC](http://www.ethree.com/CPUC).

**Electric Power Plant Operations Corresponding to Electric Chiller Operation**

The third bullet presented in Section B.1 described the additional GHG reduction benefit associated with a cogeneration facility that uses recovered waste heat for cooling in an absorption chiller. Since absorption chillers replace the use of electric chillers that operate using electricity from a central power plant, there are avoided CO<sub>2</sub> emissions associated with these cogeneration facilities.

This electricity that would have been serving an electric chiller in the absence of the cogeneration system was calculated as:

$$ChlrElec_{ih} = COOLING_{ih} \text{ kBtu} \times \left( \text{EffElecChlr} \frac{\text{kWh}}{\text{ton} - \text{hr of cooling}} \right) \left( \frac{\text{ton} - \text{hr of cooling}}{12 \text{ kBtu}} \right)$$

where:

*ChlrElec<sub>ih</sub>* is the electricity a power plant would have needed to provide for a baseline electric chiller for participant *i* for hour *h*.

Units: kWh

*COOLING<sub>ih</sub>* is the cooling service provided by SGIP CHP participant *i* for year *y*, month *m*, day *d*, and hour *h*, as calculated in section B.2.

Units: kBtu

*EffElecChlr* is the efficiency of the baseline new standard efficiency electric chiller

Value: 0.634

Units:  $\frac{\text{kWh}}{\text{Ton} - \text{hr of cooling}}$

Basis: Assumed

**Baseline GHG Emissions from Power Plant Operations**

The location- and hour-specific CO<sub>2</sub> emission rate, when multiplied by the quantity of electricity generated for each baseline scenario, estimates the *hourly emissions avoided* for participant *i*.

$$BasePpChiller_{ih} = (BaseCO2EF_{ih} \times ChlrElec_{ih})$$

$$BasePpEngo_{ih} = (BaseCO2EF_{ih} \times engohr_{ih})$$

where:



$BasePpChiller_{ih}$  is the GHG emissions generated by a power plant to provide for a baseline electric chiller for participant  $i$  for hour  $h$ .

Units: MTCDE/hr

$BasePpEngo_{ih}$  is the GHG emissions generated by a power plant to provide electricity to serve site electrical loads for participant  $i$  for hour  $h$ .

Units: MTCDE/hr

### **B.3.2 Natural Gas Boiler GHG Emissions**

The fourth bullet presented in Section B.1 described additional GHG reduction benefits derived from cogeneration. These benefits come in the form of waste heat recovered from SGIP facilities that is then used to provide heating services, thereby reducing reliance on natural gas boilers. The quantity of heating services provided by SGIP CHP systems was discussed in section B.2. Use of these data to estimate the baseline natural gas use corresponding to these heating services is described below.

SGIP CHP systems that are required to meet PUC 216.6 levels of performance and SGIP renewable landfill facilities with waste heat recovery systems have a GHG emission reduction benefit due to the offsetting emissions associated with a natural gas boiler. In PY07 and PY08 impact reports only SGIP CHP systems that were required to meet PUC 216.6 levels of performance included this baseline term. However, in PY09-PY11 impact reports some CHP systems supplied with landfill gas were included because research has found that the heat recovered from some of these CHP systems is used to meet building heating loads and in the absence of the SGIP these loads would have been satisfied by conventional means (i.e. natural gas). There are other renewable SGIP CHP systems that are fueled by digester-produced CH<sub>4</sub> gas, and the waste heat serves to maintain the temperature of the digester and maintain CH<sub>4</sub> production rates associated with the anaerobic digestion process. We assume these loads would not have been served by a natural gas boiler in the absence of the SGIP; this baseline term is therefore not included for these CHP systems.

Baseline natural gas boiler CO<sub>2</sub> emissions (measured in metric tons) were calculated based upon hourly heat recovery values for the SGIP CHP projects active in 2011 as follows:

$$BaseBlr_{ih} = \left( HEATING_{ih} \text{ kBtu}_{out} \times \left( \frac{1}{EffBlr \frac{\text{kBtu}_{out}}{\text{kBtu}_{in}}} \right) \left( \frac{ft^3 \text{ of } CH_4}{1 \text{ kBtu}_{in}} \right) \left( \frac{lbmole \text{ of } CO_2}{360 ft^3 \text{ of } CH_4} \right) \left( \frac{44 \text{ lbs of } CO_2}{lbmole \text{ of } CO_2} \right) \right) \times \left( \frac{metrictonCO_2}{2,205 \text{ lbs}CO_2} \right)$$

where:

$BaseBlr_{ih}$  is the CO<sub>2</sub> emissions of the baseline natural gas boiler for participant  $i$  for hour  $h$ .

Units: MTCDE/hr

$EffBlr$  is the efficiency of the baseline natural gas boiler

Value: 0.8

Units:  $\frac{\text{kBtu}_{out}}{\text{kBtu}_{in}}$

Basis: Previous program cost-effectiveness evaluations.

This equation reflects the ability to use recovered waste heat in lieu of natural gas and, therefore, help reduce CO<sub>2</sub> emissions.

### B.3.3 Biogas GHG Emissions

Calculation of CH<sub>4</sub> emission reductions from cogeneration facilities was carried out for the subset of 98 renewable fuel use SGIP facilities. These facilities used biogas exclusively or predominately as the generation fuel source. These included the following facility types:

- Renewable-fueled fuel cells,
- Renewable-fueled microturbines, and
- Renewable-fueled IC engines.

The baseline treatment of biogas is an influential determinant of GHG emission impacts for renewable-fueled SGIP systems. Baseline treatment refers to the typical fate of the biogas in lieu of use for energy purposes (e.g., the biogas could be vented directly to the atmosphere or flared). There are two common sources of biogas found within the SGIP: landfills and digesters. Digesters in the SGIP program to date have been associated with wastewater treatment plants (WWTPs), food processing facilities, and dairies. Because of the importance of the baseline treatment of biogas in the GHG analysis, these facilities were contacted in 2009 to more

accurately estimate baseline treatment. This resulted in the determination that venting is the baseline treatment of biogas for dairy digesters, and flaring is the baseline for all other renewable fuel sites. For dairy digesters, landfills, WWTPs, and food processing facilities larger than 150 kW, this is consistent with PY07 and PY08 SGIP impact evaluation reports. However, for WWTPs and food processing facilities smaller than 150 kW, PY07 and PY08 SGIP impact evaluations have assumed a venting baseline, whereas in PY09-PY11 impact evaluations the baseline is more accurately assumed to be flaring. Additional information on baseline treatment of biogas per biogas source and facility type is provided below.

For dairy digesters the baseline is usually to vent any generated biogas to the atmosphere. Of the approximately 2,000 dairies in California, conventional manure management practice for flush dairies<sup>6</sup> has been to pump the mixture of manure and water to an uncovered lagoon. Naturally occurring anaerobic digestion processes convert carbon present in the waste into CO<sub>2</sub>, CH<sub>4</sub>, and water. These lagoons are typically uncovered, so all CH<sub>4</sub> generated in the lagoon escapes into the atmosphere. Currently, there are no statewide requirements that dairies capture and flare the biogas, although some air pollution control districts are considering anaerobic digesters as a possible Best Available Control Technology (BACT) for control of volatile organic compounds. This information and the facility contacts support a venting biogas baseline.

For other digesters, including WWTPs and food processing facilities, the baseline is not quite as straightforward. There are approximately 250 WWTPs in California, and the larger facilities (i.e., those that could generate 1 MW or more of electricity) tend to install energy recovery systems; therefore, the baseline assumption for these facilities in past SGIP impact evaluations was flaring. However, in past SGIP impact evaluations, it was assumed that most of the remaining WWTPs do not recover energy and flare the gas on an infrequent basis. Consequently, for smaller facilities (i.e., those with capacity less than 150 kW), venting of the biogas (CH<sub>4</sub>) was used in PY07 and PY08 SGIP impact evaluations as the baseline. However, all renewable-fueled distributed generation WWTPs and food processing facilities participating in the SGIP that were contacted in 2009 said that they flare biogas, and cited local air and water regulations as the reason. Therefore, flaring was used as the biogas baseline as of the PY09 impact evaluation report.

Defining the biogas baseline for landfill gas recovery operations presented a challenge in past SGIP impact evaluations. A study conducted by the California Energy Commission in 2002<sup>7</sup>

---

<sup>6</sup> Most dairies manage their wastes via flush, scrape, or some mixture of the two processes. While manure management practices for any of these processes will result in CH<sub>4</sub> being vented to the atmosphere, flush dairies are the most likely candidates for installing anaerobic digesters (i.e., dairy biogas systems).

<sup>7</sup> California Energy Commission. *Landfill Gas-to-Energy Potential in California*. 500-02-041V1. September 2002. [http://www.energy.ca.gov/reports/2002-09-09\\_500-02-041V1.PDF](http://www.energy.ca.gov/reports/2002-09-09_500-02-041V1.PDF)

showed that landfills with biogas capacities less than 500 kW would tend to vent rather than flare the generated landfill gas by a margin of more than three to one. In addition, landfills with over 2.5 million metric tons of waste are required to collect and either flare or use their gas. However, installation verification inspection reports and renewable-fueled DG landfill facility contacts verified that they would have flared their CH<sub>4</sub> in the absence of the SGIP. Therefore, the biogas baseline for landfill facilities is to flare the CH<sub>4</sub>.

In CPUC Decision 09-09-048 (September 24, 2009), eligibility for renewable fuel use incentives was expanded to include “directed biogas” projects. Deemed to be renewable fuel use projects, directed biogas projects are eligible for higher incentives under the SGIP. Directed biogas projects purchase biogas fuel that is produced at another location. The procured biogas is processed, cleaned-up, and injected into a natural gas pipeline for distribution. Although the purchased gas is not likely to be delivered and used at the SGIP renewable fuel use project, directed biogas projects are treated in the SGIP as renewable fuel use projects.

For directed biogas projects where the biogas is injected into the pipeline outside of California, information on the renewable fuel baseline was not available.<sup>8</sup> However, it is clear that SGIP projects are consuming some amount of directed biogas that ultimately was derived from biogas sources.

In order to establish a directed biogas baseline, we made the following assumptions in lieu of better information:

1. The renewable fuel baseline for all directed biogas projects is flaring of biogas<sup>9</sup>, and
2. Seventy five percent of the energy consumed by directed biogas facilities on an energy basis (the minimum amount of biogas required to be procured by a directed biogas project) is assumed to have been injected at the biogas source.

The GHG emissions characteristics of biogas flaring and biogas venting are very different and therefore are discussed separately below.

---

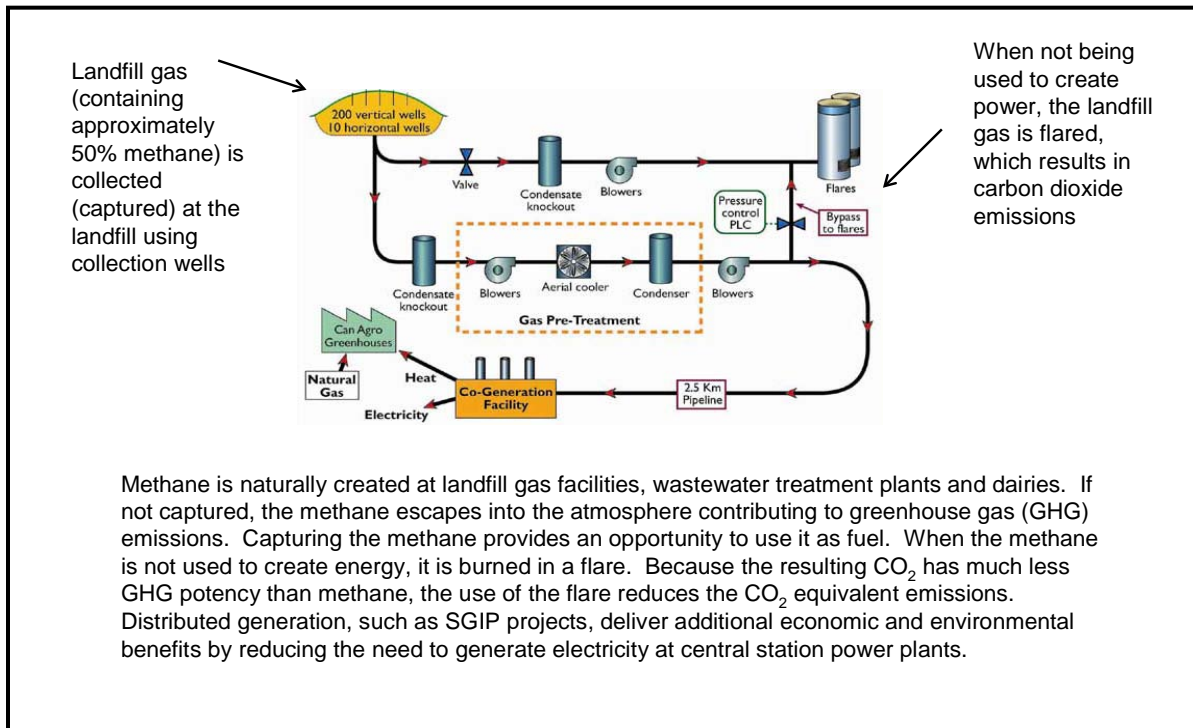
<sup>8</sup> Information on consumption of directed biogas at SGIP projects is based on invoices instead of metered data.

<sup>9</sup> From a financial feasibility perspective, directed biogas was assumed to be procured only from large biogas sources, such as large landfills. In accordance with Environmental Protection Agency regulations for large landfills, these landfills would have been required to collect the landfill gas and flare it. As a result, the basis for directed biogas projects was assumed to be flaring.

**GHG Emissions of Flared Biogas**

Figure B-2 provides a depiction of a biogas facility that captures and flares CH<sub>4</sub>. The CH<sub>4</sub> is assumed to be captured by the facility and then flared, destroying the CH<sub>4</sub> but still resulting in the release of CO<sub>2</sub>. A facility that vents the CH<sub>4</sub> will have greater direct CO<sub>2</sub> emissions than a facility that flares the CH<sub>4</sub>. This is due to the global warming potential of CH<sub>4</sub> vented directly into the atmosphere, which is much higher than the global warming potential of CO<sub>2</sub> resulting from the flaring of CH<sub>4</sub>. One metric ton of emitted CH<sub>4</sub> is equivalent to 21 MTCDE.

**Figure B-2: Landfill Gas with CH<sub>4</sub> Capture Diagram**



In situations where flaring occurs, baseline GHG emissions comprise CO<sub>2</sub> only. The flaring baseline was assumed for the following types of biogas projects:

- All facilities using digester gas except for dairies, and
- All landfill gas facilities.

$$BaseBio_{ih} = SgipGHG_{ih}$$

The assumption is that the flaring of CH<sub>4</sub> results in the same amount of CO<sub>2</sub> emissions as would occur if CH<sub>4</sub> was captured and used in the SGIP system to produce electricity.

**GHG Emissions of Vented Biogas**

CH<sub>4</sub> captured and used at renewable fuel use facilities where the biogas baseline is venting represents CH<sub>4</sub> emissions that are no longer emitted to the atmosphere. The venting baseline was assumed for all dairy digester SGIP facilities.

Biogas consumption is not metered at SGIP facilities. Therefore, CH<sub>4</sub> emission rates were calculated for each renewable fuel technology type by assuming electrical efficiencies for each technology:

$$CH_4EF_T \cong \left( \frac{3412 \text{ Btu}}{\text{kWh}} \right) \left( \frac{1}{EFF_T} \right) \left( \frac{\text{ft}^3 \text{ of } CH_4}{1000 \text{ Btu}} \right) \left( \frac{\text{lbmole of } CH_4}{360 \text{ ft}^3 \text{ of } CH_4} \right) \left( \frac{16 \text{ lb}_m \text{ of } CH_4}{\text{lbmole of } CH_4} \right) \left( \frac{454 \text{ grams}}{\text{lb}_m \text{ of } CH_4} \right)$$

where

*CH<sub>4</sub>EF<sub>T</sub>* is the CH<sub>4</sub> capture rate for SGIP DG systems of type T

Units:  $\frac{\text{grams}}{\text{kWh}}$

*EFF<sub>T</sub>* is the electrical efficiency of technology T.

Value: Value dependent on technology type

Technology Type	<i>EFF<sub>T</sub></i>
Fuel Cell – CHP	0.384
IC Engine	0.315
Microturbine	0.233

Units: Dimensionless fractional efficiency

Basis: Lower heating value (LHV).

Metered data collected from SGIP CHP systems.

The derived CH<sub>4</sub> emission rates (*CH<sub>4</sub>EF*) are multiplied by the total electricity generated from the SGIP renewable fuel use sites to estimate baseline CH<sub>4</sub> emissions.

$$BaseBioCH_{4_{ih}} = \left( \left( \frac{CH_4EF_T \text{ grams}}{\text{kWh}} \right) \left( \text{engohr}_{ih} \right) \left( \frac{0.002204 \text{ lbs}}{\text{grams}} \right) \right) \times \left( \frac{\text{metric ton } CH_4}{2,205 \text{ lbs } CH_4} \right)$$

The avoided metric tons of CH<sub>4</sub> emissions were then converted to metric tons of CO<sub>2</sub> equivalent by multiplying the avoided CH<sub>4</sub> emissions by 21, which represents the Global Warming Potential (GWP) of CH<sub>4</sub> (relative to CO<sub>2</sub>) over a 100-year time horizon.

$$BaseBio_{ih} = BaseBioCH4_{ih} * \left( \frac{21 \text{ metric tons } CO_2}{\text{metric ton } CH_4} \right)$$

## B.4 Emission Details by PA, Technology and Fuel

**Table B-1: GHG Emission Impacts for all PAs by Technology Type and Fuel (Metric Tons of CO<sub>2</sub> Equivalents)**

Program Administrator, System Type, and Fuel	SGIP GHG Emissions (MTCDE)	Baseline Emissions (MTCDE)					GHG Emissions Impact (MTCDE)
		Electric Power Plant	Heating Services	Cooling Services	Biogas Treatment	Total Baseline Emissions	
<b>CCSE</b>	<b>61,043</b>	<b>43,947</b>	<b>2,391</b>	<b>808</b>	<b>5,195</b>	<b>52,341</b>	<b>8,702</b>
FC	5,449	5,023	293	3	1,592	6,911	-1,462
Biogas-Directed	2,123	2,190	0	0	1,592	3,782	-1,659
NatGas	3,326	2,833	293	3	0	3,129	197
GT	45,104	31,985	1,016	654	0	33,655	11,449
NatGas	45,104	31,985	1,016	654	0	33,655	11,449
ICE	8,130	5,721	727	135	2,753	9,336	-1,206
Biogas-Flared	2,753	1,887	0	0	2,753	4,640	-1,887
NatGas	5,378	3,834	727	135	0	4,696	681
MT	2,360	1,218	355	16	850	2,439	-79
Biogas-Flared	850	432	114	0	850	1,396	-546
NatGas	1,510	786	240	16	0	1,043	468
<b>PG&amp;E</b>	<b>178,555</b>	<b>129,331</b>	<b>27,017</b>	<b>1,061</b>	<b>66,003</b>	<b>223,411</b>	<b>-44,856</b>
FC	43,371	41,546	1,789	30	17,281	60,645	-17,274
Biogas-Directed	19,862	20,583	0	0	14,897	35,479	-15,617
Biogas-Flared	2,384	2,042	0	0	2,384	4,426	-2,042
NatGas	21,125	18,921	1,789	30	0	20,740	386
GT	11,465	8,167	1,541	125	0	9,833	1,632
NatGas	11,465	8,167	1,541	125	0	9,833	1,632
ICE	87,540	61,047	17,696	762	45,835	125,340	-37,800
Biogas-Flared	14,790	10,212	1,338	0	14,790	26,340	-11,550
Biogas-Vented	4,063	2,795	0	0	31,045	33,840	-29,777
NatGas	68,687	48,040	16,358	762	0	65,160	3,527

**Table B-2: GHG Emission Impacts for all PAs by Technology Type and Fuel (Metric Tons of CO<sub>2</sub> Equivalents)—Continued**

Program Administrator, System Type, and Fuel	SGIP GHG Emissions (MTCDE)	Baseline Emissions (MTCDE)					GHG Emissions Impact (MTCDE)
		Electric Power Plant	Heating Services	Cooling Services	Biogas Treatment	Total Baseline Emissions	
MT	36,179	18,571	5,991	144	2,887	27,593	8,585
Biogas-Flared	2,887	1,487	0	0	2,887	4,374	-1,487
NatGas	33,292	17,084	5,991	144	0	23,219	10,073
<b>SCE</b>	<b>51,007</b>	<b>36,980</b>	<b>6,041</b>	<b>524</b>	<b>17,484</b>	<b>61,029</b>	<b>-10,022</b>
FC	11,857	11,260	131	0	8,188	19,579	-7,722
Biogas-Directed	5,000	5,193	0	0	3,750	8,942	-3,943
Biogas-Flared	4,438	3,789	0	0	4,438	8,228	-3,789
NatGas	2,419	2,278	131	0	0	2,409	10
ICE	31,082	21,577	4,868	366	8,968	35,779	-4,697
Biogas-Flared	8,968	6,178	860	0	8,968	16,006	-7,038
NatGas	22,114	15,400	4,008	366	0	19,773	2,341
MT	8,068	4,143	1,042	158	328	5,671	2,397
Biogas-Flared	328	169	0	0	328	497	-169
NatGas	7,740	3,974	1,042	158	0	5,174	2,566
<b>SCG</b>	<b>157,161</b>	<b>111,295</b>	<b>24,104</b>	<b>3,032</b>	<b>19,447</b>	<b>157,878</b>	<b>-716</b>
FC	18,271	16,840	340	0	12,023	29,204	-10,932
Biogas-Direct	5,517	5,694	0	0	4,138	9,832	-4,315
Biogas-Flared	7,885	6,712	0	0	7,885	14,597	-6,712
NatGas	4,869	4,434	340	0	0	4,774	94
GT	54,503	38,629	9,661	1,223	0	49,512	4,991
NatGas	54,503	38,629	9,661	1,223	0	49,512	4,991
ICE	68,482	47,721	11,945	1,599	7,424	68,689	-207
Biogas-Flared	7,424	5,117	0	0	7,424	12,541	-5,117
NatGas	61,058	42,604	11,945	1,599	0	56,148	4,909
MT	15,905	8,105	2,157	211	0	10,473	5,432
NatGas	15,905	8,105	2,157	211	0	10,473	5,432



**Table B-3: Emission Impact Factors for All PAs by Technology Type and Fuel (Tons of CO<sub>2</sub> equivalents per MWh)**

Program Administrator, System Type, and Fuel	Annual Energy Impact (MWh)	SGIP GHG Emissions (MTCDE per MWh)	Baseline Emissions (MTCDE per MWh)					GHG Emissions Impact (MTCDE per MWh)
			Electric Power Plant	Heating Services	Cooling Services	Biogas Treatment	Total Baseline Emissions	
<b>CCSE</b>	<b>104,191</b>	<b>0.59</b>	<b>0.42</b>	<b>0.02</b>	<b>0.01</b>	<b>0.05</b>	<b>0.50</b>	<b>0.08</b>
FC	11,960	0.46	0.42	0.02	0.00	0.13	0.58	-0.12
Biogas-Directed	5,209	0.41	0.42	0.00	0.00	0.31	0.73	-0.32
NatGas	6,751	0.49	0.42	0.04	0.00	0.00	0.46	0.03
GT	76,077	0.59	0.42	0.01	0.01	0.00	0.44	0.15
NatGas	76,077	0.59	0.42	0.01	0.01	0.00	0.44	0.15
ICE	13,284	0.61	0.43	0.05	0.01	0.21	0.70	-0.09
Biogas-Flared	4,498	0.61	0.42	0.00	0.00	0.61	1.03	-0.42
NatGas	8,786	0.61	0.44	0.08	0.02	0.00	0.53	0.08
MT	2,870	0.82	0.42	0.12	0.01	0.30	0.85	-0.03
Biogas-Flared	1,033	0.82	0.42	0.11	0.00	0.82	1.35	-0.53
NatGas	1,837	0.82	0.43	0.13	0.01	0.00	0.57	0.25
<b>PG&amp;E</b>	<b>304,748</b>	<b>0.59</b>	<b>0.42</b>	<b>0.09</b>	<b>0.00</b>	<b>0.22</b>	<b>0.73</b>	<b>-0.15</b>
FC	98,386	0.44	0.42	0.02	0.00	0.18	0.62	-0.18
Biogas-Directed	48,729	0.41	0.42	0.00	0.00	0.31	0.73	-0.32
Biogas-Flared	4,841	0.49	0.42	0.00	0.00	0.49	0.91	-0.42
NatGas	44,816	0.47	0.42	0.04	0.00	0.00	0.46	0.01
GT	19,338	0.59	0.42	0.08	0.01	0.00	0.51	0.08
NatGas	19,338	0.59	0.42	0.08	0.01	0.00	0.51	0.08

**Table B-4: Emission Impact Factors for All PAs by Technology Type and Fuel (Tons of CO<sub>2</sub> equivalents per MWh)—Continued**

Program Administrator, System Type, and Fuel	Annual Energy Impact (MWh)	SGIP GHG Emissions (MTCDE per MWh)	Baseline Emissions (MTCDE per MWh)					GHG Emissions Impact (MTCDE per MWh)
			Electric Power Plant	Heating Services	Cooling Services	Biogas Treatment	Total Baseline Emissions	
ICE	143,026	0.61	0.43	0.12	0.01	0.32	0.88	-0.26
Biogas-Flared	24,164	0.61	0.42	0.06	0.00	0.61	1.09	-0.48
Biogas-Vented	6,638	0.61	0.42	0.00	0.00	4.68	5.10	-4.5
NatGas	112,224	0.61	0.43	0.15	0.01	0.00	0.58	0.03
MT	43,998	0.82	0.42	0.14	0.00	0.07	0.63	0.20
Biogas-Flared	3,511	0.82	0.42	0.00	0.00	0.82	1.25	-0.42
NatGas	40,487	0.82	0.42	0.15	0.00	0.00	0.57	0.25
<b>SCE</b>	<b>87,287</b>	<b>0.58</b>	<b>0.42</b>	<b>0.07</b>	<b>0.01</b>	<b>0.20</b>	<b>0.70</b>	<b>-0.11</b>
FC	26,693	0.44	0.42	0.00	0.00	0.31	0.73	-0.29
Biogas-Directed	12,266	0.41	0.42	0.00	0.00	0.31	0.73	-0.32
Biogas-Flared	9,012	0.49	0.42	0.00	0.00	0.49	0.91	-0.42
NatGas	5,415	0.45	0.42	0.02	0.00	0.00	0.44	0.00
ICE	50,783	0.61	0.42	0.10	0.01	0.18	0.70	-0.09
Biogas-Flared	14,652	0.61	0.42	0.06	0.00	0.61	1.09	-0.48
NatGas	36,131	0.61	0.43	0.11	0.01	0.00	0.55	0.06
MT	9,811	0.82	0.42	0.11	0.02	0.03	0.58	0.24
Biogas-Flared	399	0.82	0.42	0.00	0.00	0.82	1.25	-0.42
NatGas	9,413	0.82	0.42	0.11	0.02	0.00	0.55	0.27

**Table B-5: Emission Impact Factors for All PAs by Technology Type and Fuel (Tons of CO<sub>2</sub> equivalents per MWh)—Continued**

Program Administrator, System Type, and Fuel	Annual Energy Impact (MWh)	SGIP GHG Emissions (MTCDE per MWh)	Baseline Emissions (MTCDE per MWh)					GHG Emissions Impact (MTCDE per MWh)
			Electric Power Plant	Heating Services	Cooling Services	Biogas Treatment	Total Baseline Emissions	
<b>SCG</b>	<b>263,290</b>	<b>0.60</b>	<b>0.42</b>	<b>0.09</b>	<b>0.01</b>	<b>0.07</b>	<b>0.60</b>	<b>-0.00</b>
FC	40,129	0.46	0.42	0.01	0.00	0.30	0.73	-0.27
Biogas-Directed	13,536	0.41	0.42	0.00	0.00	0.31	0.73	-0.32
Biogas-Flared	16,010	0.49	0.42	0.00	0.00	0.49	0.91	-0.42
NatGas	10,583	0.46	0.42	0.03	0.00	0.00	0.45	0.01
GT	91,930	0.59	0.42	0.11	0.01	0.00	0.54	0.05
NatGas	91,930	0.59	0.42	0.11	0.01	0.00	0.54	0.05
ICE	111,888	0.61	0.43	0.11	0.01	0.07	0.61	-0.00
Biogas-Flared	12,130	0.61	0.42	0.00	0.00	0.61	1.03	-0.42
NatGas	99,758	0.61	0.43	0.12	0.02	0.00	0.56	0.05
MT	19,343	0.82	0.42	0.11	0.01	0.00	0.54	0.28
NatGas	19,343	0.82	0.42	0.11	0.01	0.00	0.54	0.28

# Appendix C

## Data Sources and Data Analysis

---

This appendix discusses data sources and data availability by Program Administrator (PA) and the data analysis methodology, including the bases of the impact estimates uncertainty characterizations. Several key types of data sources are presented first. This is followed by a description of metered data collection issues. The last section describes the data analysis.

### C.1 Overview of Key Data Types

There are three key data types:

1. Project lists maintained by the Program Administrators (PAs),
2. Reports from monitoring planning and installation verification site visits, and
3. Metered data received from project Hosts, Applicants, third-party metering, or metering installed by Itron.

#### C.1.1 Project Lists Maintained by Program Administrators

SGIP PAs maintain a statewide project tracking database containing information essential for designing and conducting SGIP impact evaluation activities. The PAs provided Itron with access to the statewide database for purposes of downloading project tracking data necessary to plan and implement program impacts evaluation activities. Information of particular importance includes basic project characteristics (e.g., technology type, rebated capacity of the project, fuel type) and key participant characteristics (e.g., Host and Applicant names<sup>1</sup>, addresses, and phone numbers). The project's technology type, program year, and project location (by PA area) were also used in developing a sample design to ensure collection of data necessary to develop

---

<sup>1</sup> The Host is the customer of record at the site where the generating equipment is or will be located. An Applicant is a person or entity who applies to the PA for incentive funding. Third parties (e.g., a party other than the PA or the utility customer) such as engineering firms, installing contractors, equipment distributors or Energy Service Companies (ESCO) are also eligible to apply for incentives on behalf of the utility customer, provided consent is granted in writing by the customer.

statistically significant estimates of program impacts. Updated SGIP Handbooks were used for planning and reference purposes.<sup>2</sup>

### ***C.1.2 Reports from Monitoring Planning and Installation Verification Site Visits***

Information obtained from the PA project database was augmented and updated through visits to the SGIP project sites conducted by independent consultants hired by the PAs to perform verification of SGIP installations. Project-specific information is reported in Inspection Reports produced by these independent consultants. The PAs regularly provided copies of the Inspection Reports. In addition, site visits were conducted by Itron engineers in preparing monitoring plans for on-site data collection activities. The types of information collected during site inspections or in preparation of monitoring plans include meter numbers, nominal nameplate rating, and the date the system entered normal operation.

### ***C.1.3 Metered Performance Data***

In addition to information collected from the PA project database and from project site visits, metered data were also used when available. The metered data collected and used for evaluation purposes include electric net generator output (ENGO) data, useful thermal energy (HEAT) data, and fuel use (FUEL) data.

#### ***Electric Net Generator Output (ENGO) Data***

ENGO data provide information on the amount of electricity generated by the metered SGIP project. This information is needed to assess annual and peak electricity contributions from SGIP projects. ENGO data were collected from a variety of sources, including meters Itron installed on SGIP projects under the direction of the PAs and meters installed by project Hosts, Applicants, electric utilities, and third parties.

#### ***Useful Thermal Energy (HEAT) Data***

Useful thermal energy is that energy captured by heat recovery equipment and used at the utility customer site to satisfy heating and/or cooling loads. Useful thermal energy (also referred to as HEAT) data were used to assess compliance of SGIP cogeneration facilities with required levels of efficiency and useful waste heat recovery. In addition, useful thermal energy data for SGIP facilities enabled estimation of baseline electricity and natural gas use that would have otherwise been provided by the utility companies. This information was used to assess energy efficiency impacts as well as calculate GHG emission impact estimates. HEAT data were collected from metering systems installed by Itron as well as metering systems installed by Applicants, Hosts, or third parties.

---

<sup>2</sup> SGIP Handbooks are available on PA websites.

Over the course of the SGIP, the approach for collecting HEAT data has changed. Collecting HEAT data has historically involved installation of invasive monitoring equipment (i.e., insertion-type flow meters and temperature sensors). Many third parties or Hosts had this type of HEAT metering equipment installed at the time the SGIP project was commissioned, either as part of their contractual agreement with a third-party vendor or as part of an internal process/energy monitoring plan. In numerous cases, Itron was able to obtain the relevant data being collected by these Hosts and third parties. Itron initially adopted an approach of obtaining HEAT data from others in an effort to minimize both the cost- and disruption-related aspects of installing HEAT monitoring equipment. The majority of useful thermal energy data for 2003 to 2004 were obtained in this manner.

Itron began installing HEAT meter systems in the summer of 2003 for SGIP projects that were included in the sample design but for which data from existing HEAT metering were not available. As the HEAT data collection effort grew, it became clear that Itron could no longer rely on data from third-party or Host customer metering. In numerous instances agreements and plans concerning these data did not translate into validated data records available for analysis. Uninterrupted collection and validation of reliable metered performance data was labor-intensive and required examination of the collected data by more expert staff, thereby increasing costs. In addition, reliance on HEAT data collected by SGIP Host customers and third parties created evaluation schedule impacts and other risks that more than outweighed the benefits of lower metering installation costs.

In mid-2006, Itron responded to the HEAT data issues by changing the approach to collection of HEAT data. Itron continued to collect HEAT data from others in those instances where the data could be obtained easily and reliably. In all other instances, an approach has been adopted of installing HEAT metering systems for those projects in the sample design. Itron adopted the installation of non-invasive metering equipment such as ultrasonic flow meters, clamp-on temperature sensors, and wireless, cellular-based communications to reduce the time and invasiveness of the installations and increase data communication reliability. The increase in equipment costs was offset by the decrease in installation time and a decrease in maintenance problems. This non-invasive approach has been used to obtain HEAT data throughout 2011.

### **Fuel Usage (FUEL) Data**

Fuel usage (also called FUEL) data were used in the impact evaluation to determine overall system efficiencies of SGIP cogeneration facilities, to determine compliance of renewable fuel use facilities with renewable fuel use requirements, and to estimate GHG emission impacts. To date, fuel use data collection activities have focused exclusively on monitoring consumption of natural gas by SGIP generators. In the future it may also be necessary to monitor consumption of gaseous renewable fuel (i.e., biogas) to more accurately assess compliance of SGIP projects using blends of renewable and non-renewable fuels with renewable fuel use requirements.

FUEL data used in the impact evaluation were obtained mostly from FUEL metering systems installed at SGIP projects by natural gas utilities, SGIP participants, or by third parties. Itron reviewed FUEL data obtained from others, and their bases were documented prior to processing the FUEL data into a data warehouse. Reviews of data validity included combining fuel usage data with power output data to check for reasonableness of gross engine/turbine electrical conversion efficiency. In cases where validity checks failed, the data provider was contacted to further refine the basis of data. In some cases it was determined that data received were for a facility-level meter rather than from metering dedicated to the SGIP cogeneration system. These data were excluded from the impact analysis.

Most of the FUEL data being obtained from others were collected and reported on in time intervals much greater than one hour (e.g., daily or monthly). In most instances hourly FUEL consumption was estimated based on the associated ENGO readings. While these data enable calculation of monthly and annual operating efficiencies they do not provide information about cogeneration system efficiency during peak electricity demand. To address this issue Itron has recommended to the PAs installation of pulse recorders on a subset of existing gas meters to enable collection of hourly FUEL data.

## **C.2 Data Processing Methods**

This section discusses the ENGO, HEAT, and FUEL data processing and validation methodology for fuel cells and engines/turbines operating on non-renewable or renewable fuel.

### **C.2.1 ENGO Data Processing**

For fuel cells, engines, and turbines, ENGO data refers to a measure of system output that accounts for electric parasitic loads (e.g., onsite controls, pumps, fans, compressors, generators, and heat recovery systems). In some cases it is not possible to measure ENGO directly with a single meter. In those cases ENGO is calculated by subtracting the electrical parasitic loads from the gross generator output. Due to the wide variety of formats in which raw data are received, conversion of raw data to a common format is essential to ensure that all data received are treated consistently. After converting the data to a common format, all data files are reviewed to identify suspicious data (low or high capacity factors). Data providers are contacted when data validity cannot be determined internally. In cases where anomalous behavior cannot be explained, the metered data are excluded from the analysis.

### **C.2.2 HEAT Data Processing**

The main sources of thermal data are Applicants and Itron-installed heat meters. If the data come from Itron data loggers, processing time is minimal because the raw data are already stored in 15-minute intervals. However, if the raw data come from Applicants, then the data are

converted to the standard format of 15-minute interval kBtu data. When data are received from an Applicant, Host, or some other party, certain validation steps must be passed before the data are incorporated into the analysis. These steps include comparing the HEAT data with the ENGO and FUEL data when available. HEAT data are validated when the heat recovery rate (kBtu/kWh) falls within an expected range based on system type and size.

### **C.2.3 FUEL Data Processing**

The two main sources of fuel data for non-renewable projects are natural gas utilities and program participants. These raw data are typically reported in monthly or billing cycle intervals. Monthly electrical conversion efficiencies are calculated to validate the monthly fuel data. Validated monthly data are transformed into 15-minute data based on the monthly electrical efficiencies and 15-minute ENGO data. In this case, the fuel data are allocated to 15-minute intervals using a ratio, so a flag in the permanent dataset is set to “R” in order to distinguish between monthly metered data that has been transformed into 15-minute data, and actual 15-minute interval metered data, which are flagged as “M”.

## **C.3 Estimating Impacts of Unmetered Systems**

Data from metered systems were used to estimate impacts for unmetered systems of the same technology and fuel. In most cases, the metered data were for the exact same hour of the year and from systems of same technology, fuel, and PA.

By limiting the metered data used to those with the same PA, factors that can influence operational performance were better matched between the metered and unmetered systems. These PA-related factors include local economic climate, available tariffs, and, to some degree, the local meteorological climate.

All estimated hourly impacts were based on no fewer than five metered observations of the same technology and fuel type. For some unmetered systems there were hours with fewer than five metered observations of the same technology and fuel types, as well as the same PAs. To estimate impacts for these, metered data from one or more of the other PAs were included until there were at least five metered observations for the same hour. For example, metered data from SCE could be used to estimate impacts for similar systems at the same hour for SCG unmetered systems when too few metered observations existed from SCG systems alone. If there still were fewer than five metered observations, then data from CCSE were allowed to be used. If inclusion of CCSE data did not provide enough metered observations, then data from PG&E were allowed.

The inclusion of metered data from other PAs did not always satisfy the minimum requirement of five metered observations for the same hour of the year and same technology and fuel. In these cases the metered data were restricted again to the same PA but the time component of the



metered data was allowed to include same hours of the day from like weekday types (weekday or weekend) from the same month. For example, an hourly estimate for 3:00 to 4:00 P.M. on Monday, July 24 for a renewable IC engine system administered by SCE might be based on metered observations from renewable IC engine systems administered by SCE from all July weekday hours of 3:00 to 4:00 P.M.

In less than 0.2% of the system hours needing to be estimated, the relaxation of the metered data time component did not satisfy the minimum requirement of five metered observations. Thus, estimates for these system hours were allowed to be based on metered observations during like weekday hours of the same month and from other PAs.

A ratio representing average power output per unit of rebated system capacity was calculated using at least five metered observations for each system hour needing an impact estimate. Two sets of these ratios were calculated, one set based on all available metered data, and one set based only on metered data for systems that were online. The latter set of ratio estimators were used to calculate impacts estimates for unmetered projects that operations status research determined to be online.

The operations status of each metered system and each unmetered system was defined on a month by month basis. For metered systems, monthly average capacity factors were used as the basis of operations status assignment. System-months associated with monthly average capacity factors less than or equal to 1% were classified as offline; monthly average capacity factors greater than or equal to 1% were classified as online. Hourly estimates of impacts were calculated as the product of the ratio estimator and the size of the unmetered system as shown below.

$$ENG\hat{O}_{psdh} = (S_{ps})_{Unmetered} \times \left( \frac{\sum ENGO_{psdh}}{\sum S_{ps}} \right)_{Metered}$$

Where:

$ENG\hat{O}_{psdh}$  = Predicted net generator output for project  $p$  in strata<sup>3</sup>  $s$  on date  $d$  during hour  $h$

Units: kWh

Source: Calculated

---

<sup>3</sup> Strata are always defined by like technology and fuel and like hour of like weekday in like month. As described in text, however, strata may be more specific by additional like technology details, like PA or like group of PAs, and by exact hour of the year.

$S_{ps}$  = System size for project  $p$  in strata  $s$

Units: kW

Source: SGIP Tracking Database

$ENGO_{psdh}$  = Metered net generator output for project  $p$  in strata  $s$  on date  $d$  during hour  $h$

Units: kWh

Source: Net Generator Output Meters

## C.4 Assessing Uncertainty of Impacts Estimates

Program impacts covered include those on electricity and fuel, as well as those on greenhouse gas (GHG) emissions. The principal factors contributing to uncertainty in those reported results are quite different for these two types of program impacts. The treatment of those factors is described below for each of the two types of impacts.

### C.4.1 Electricity, Fuel, and Heat Impacts

Electricity, fuel, and heat impact estimates are affected by at least two sources of error that introduce uncertainty into the estimates: measurement error and sampling error. Measurement error refers to the differences between actual values (e.g., actual electricity production) and measured values (i.e., electricity production values recorded by metering and data collection systems). Sampling error refers to differences between actual values and values estimated for unmetered systems. The estimated impacts calculated for unmetered systems are based on the assumption that performance of unmetered systems is identical to the average performance exhibited by groups of similar metered projects. Very generally, the *central tendency* (i.e., an average) of metered systems is used as a proxy for the central tendency of unmetered systems.

The actual performance of unmetered systems is not known, and will never be known. It is therefore not possible to directly assess the validity of the assumption regarding identical central tendencies. However, it is possible to examine this issue indirectly by incorporating information about the performance *variability* characteristics of the systems.

Theoretical and empirical approaches exist to assess uncertainty effects attributable to both measurement and sampling error. Propagation of error equations are a representative example of theoretical approaches. Empirical approaches to quantification of impact estimate uncertainty are not grounded on equations derived from theory. Instead, information about factors contributing to uncertainty is used to create large numbers of possible sets of actual values for unmetered systems. Characteristics of the sets of simulated actual values are analyzed. Inferences about the uncertainty in impact estimates are based on results of this analysis.

For this impact evaluation an empirical approach known as Monte Carlo Simulation (MCS) analysis was used to quantify impact estimates uncertainty. The term MCS refers to “the use of random sampling techniques and often the use of computer simulation to obtain approximate solutions to mathematical or physical problems especially in terms of a range of values each of which has a calculated probability of being the solution.”<sup>4</sup>

A principle advantage of this approach is that it readily accommodates complex analytic questions. This is an important advantage for this project because numerous factors contribute to variability in impact estimates, and the availability of metered data upon which to base impact estimates is variable. For example, metered electricity production and heat recovery data are both available for some cogeneration systems, whereas other systems may also include metered fuel usage, while still others might have other combinations of data available.

#### ***C.4.2 GHG Emission Impacts***

Electricity and fuel impact estimates represent the starting point for the analysis of GHG emission impacts; thus, uncertainty in those electricity and fuel impact estimates flows down to the GHG emissions impact estimates. However, additional sources of uncertainty are introduced in the course of the GHG emissions impacts analysis. GHG emissions impact estimates are, therefore, subject to greater levels of uncertainty than are electricity and fuel impact estimates. The two most important additional sources of uncertainty in GHG emissions impacts are summarized below.

##### ***Baseline Central Station Power Plant GHG Emissions***

Estimation of net GHG emissions impacts of each SGIP system involves comparing emissions of the SGIP system with emissions that would have occurred in the absence of the program. The latter quantity depends on the central station power plant generation technology (e.g., natural gas combined cycle, natural gas turbine) that would have met the participant’s electric load if the SGIP system had not been installed. Data concerning marginal baseline generation technologies and their efficiencies (and, hence, GHG emissions factors) were obtained from E3. Quantitative assessment of uncertainty in E3’s avoided GHG emissions database is outside the scope of this SGIP impact evaluation.

##### ***Baseline Biogas Project GHG Emissions***

Biomass material (e.g., trash in landfills, manure at dairies) would typically have existed and decomposed (releasing methane (CH<sub>4</sub>)) even in the absence of the program. While the program does not influence the existence or decomposition of the biomass material, it may impact

---

<sup>4</sup> Webster’s dictionary

whether or not the CH<sub>4</sub> is released directly into the atmosphere. This is critical because CH<sub>4</sub> is a much more active GHG than are the products of its combustion (e.g., CO<sub>2</sub>).

For this GHG impact evaluation Itron used the CH<sub>4</sub> disposition baseline assumptions summarized in Table C-1. Due to the influential nature of this factor, and given the current relatively high level of uncertainty surrounding assumed baselines, Itron continues collecting additional site-specific information about CH<sub>4</sub> disposition and incorporating it into impacts analyses. Modification of installation verification inspection forms will be recommended, and information available from air permitting and other information sources will be compiled.

**Table C-1: CH<sub>4</sub> Disposition Baseline Assumptions for Biogas Projects**

<b>Renewable Fuel Facility Type</b>	<b>Methane Disposition Baseline Assumption</b>
Dairy Digester	Venting
Waste Water Treatment Landfill Gas Recovery	Flaring

**C.4.3 Data Sources**

The usefulness of MCS results rests on the degree to which the factors underlying the simulations of actual performance of unmetered systems resemble factors known to influence those SGIP systems for which impact estimates are being reported. Several key sources of data for these factors are described briefly below.

**SGIP Project Information**

Basic project identifiers include PA, project status, project location, system type, and system size. This information is obtained from project lists that PAs update monthly for the CPUC. More detailed project information (e.g., heat exchanger configuration) is obtained from Verification Inspection Reports developed by PAs just prior to issuance of incentive checks.

**Metered Data for SGIP DG Systems**

Collection and analysis of metered performance data collected from SGIP DG systems is a central focus of the overall program evaluation effort. In the MCS study the metered performance data are used for three principal purposes:

1. Metered data are used to estimate the actual performance of metered systems. The metered data are not used directly for this purpose. Rather, information about measurement error is applied to metered values to estimate actual values.
2. The central tendencies of groups of metered data are used to estimate the actual performance of unmetered systems.

3. The variability characteristics exhibited by groups of metered data contribute to development of distributions used in the MCS study to explore the likelihood that actual performance of unmetered systems deviates by certain amounts from estimates of their performance.

### **Manufacturer's Technical Specifications**

Metering systems are subject to measurement error. The values recorded by metering systems represent very close approximations to actual performance; they are not necessarily identical to actual performance. Technical specifications available for metering systems provide information necessary to characterize the difference between measured values and actual performance.

### **C.4.4 Analytic Methodology**

The analytic methodology used for the MCS study is described in this section. The discussion is broken down into five steps:

- Ask Question
- Design Study
- Generate Sample Data
- Calculate the Quantities of Interest for Each Sample
- Analyze Accumulated Quantities of Interest

### **Ask Question**

The first step in the MCS study is to clearly describe the question(s) that the MCS study was designed to answer. In this instance, that question is: How confident can one be that *actual* program total impact deviates from *reported* program total impact by less than certain amounts? The scope of the MCS study includes the following program total impacts:

- Program Total Annual Electrical Energy Impacts
- Program Total Coincident Peak Electrical Demand Impacts
- Program Total PUC 216.6(b) Cogeneration System Efficiency

### **Design Study**

The MCS study's design determines requirements for generation of sample data. The process of specifying study design includes making tradeoffs between flexibility, accuracy, and cost. This MCS study's tradeoffs pertain to treatment of the dynamic nature of the SGIP and to treatment of the variable nature of data availability. Some of the systems came on-line during 2011 and, therefore, contributed to energy impacts for only a portion of the year. Some of the systems for

which metered data are available have gaps in the metered data archive that required estimation of impacts for a portion of hours during 2011. These issues are discussed below.

Sample data for each month of the year could be simulated, and then annual electrical energy impacts could be calculated as the sum of monthly impacts. Alternatively, sample energy production data for entire years could be generated. An advantage of the monthly approach is that it accommodates systems that came on-line during 2011 and, therefore, contributed to energy impacts for only a portion of the year. The disadvantage of using monthly simulations is that this approach is 12 times more labor- and processor-intensive than an annual simulation approach.

A central element of the MCS study involves generation of actual performance values (i.e., sample data) for each simulation run. The method used to generate these values depends on whether or not the system is metered. However, for many of the SGIP systems, metered data are available for a portion—but not all—of 2011. This complicates any analysis that requires classification of systems as either “metered” or “not metered.”

An effort was made to accommodate the project status and data availability details described above without consuming considerable time and resources. To this end, two important simplifying assumptions are included in the MCS study design.

1. Each data archive (e.g., electricity, fuel, heat) for each month of each project is classified as being either “metered” (at least 90% of any given month’s reported impacts are based on metered data) or “unmetered” (less than 90% of any given month’s reported impacts are based on metered data) for MCS purposes.
2. An operations status of “Normal” or “Unknown” was assigned to each month of each unmetered system based on research performed.

### **Generate Sample Data**

Actual values for each of the program impact estimates identified above (“Ask Question”) are generated for each sample (i.e., “run” or simulation).

If metered data are available for the system then the actual values are created by applying a measurement error to the metered values. If metered data are not available for the system, the actual values are created using distributions that reflect performance variability assumptions. **A total of 10,000 simulation runs were used to generate sample data.**

*Metered Data Available—Generating Sample Data that Include Measurement Error*

The assumed characteristics of random measurement-error variables are summarized in Table C-2. The ranges are based on typical accuracy specifications from manufacturers of metering equipment (e.g., specified accuracy of +/- 2%). A uniform distribution with mean equal to zero is assumed for all three measurement types. This distribution implies that any error value within the stated range has an identical probability of occurring in any measurement. This distribution is more conservative than some other commonly assumed distributions (e.g., normal “bell-shaped” curve) because the outlying values are just as likely to occur as the central values.

**Table C-2: Summary of Random Measurement-Error Variables**

<b>Measurement</b>	<b>Range</b>	<b>Mean</b>	<b>Distribution</b>
Electricity	-0.5% to 0.5%	0%	Uniform
Natural gas	-2% to 2%		
Heat recovered	-5% to 5%		

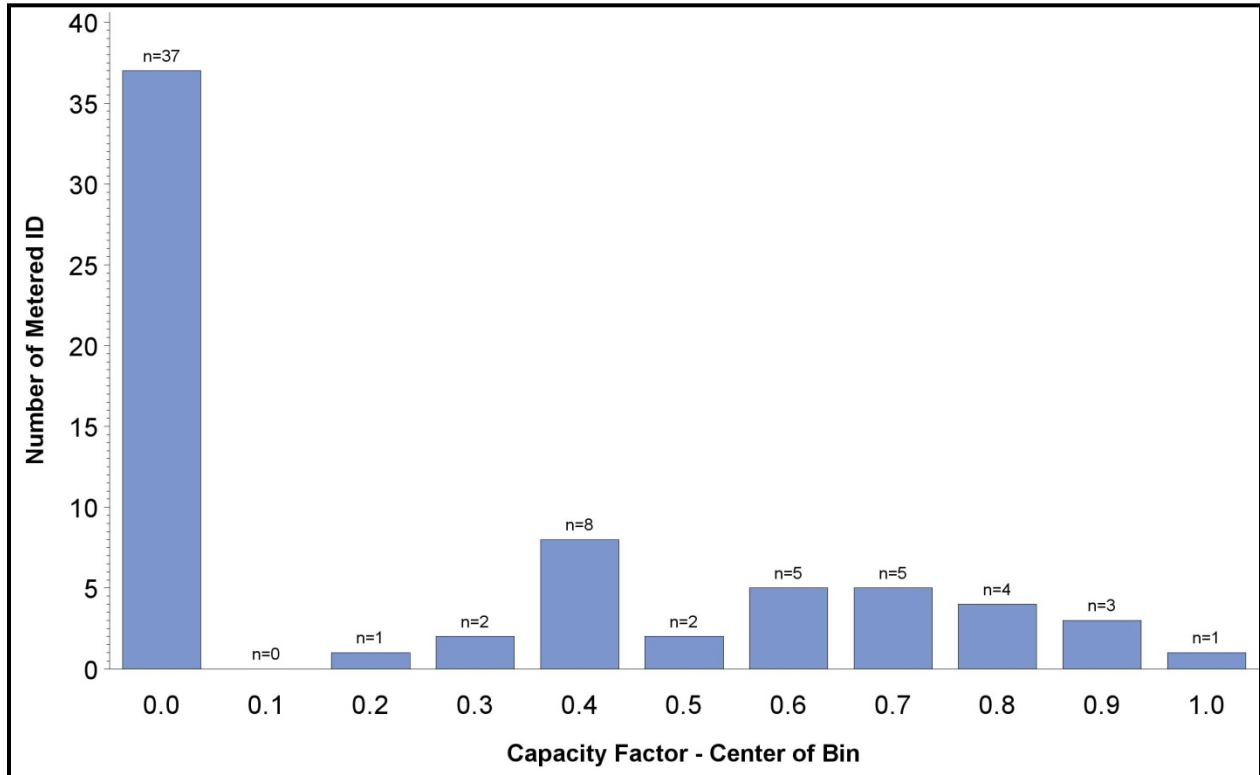
*Metered Data Unavailable—Generating Sample Data from Performance Distributions*

In the case of unmetered sites, the sample data are generated by random assignment from distributions of performance values assumed representative of entire groups of unmetered sites. Because measured performance data are not available for any of these sites, the natural place to look first for performance values is similar metered systems.

Specification of performance distributions for the MCS study involves a degree of judgment in at least two areas: first, in deciding whether or not metered data available for a stratum are sufficient to provide a realistic indication of the distribution of values likely for the unmetered systems; second, when metered data available for a stratum are not sufficient, in deciding when and how to incorporate the metered data available for other strata into a performance distribution for the data-insufficient stratum.

The assessment of the suitability of available metered data for use in MCS performance distributions is illustrated below with an example using recent data from 2008. The output of a group of non-renewable-fueled microturbines during the hour when CAISO system load reached its annual peak value is illustrated in Figure C-1. In this figure microturbine system output is expressed as metered power output per unit of system rebated capacity (Capacity Factor). Metered data were available for 67 systems. There were 72 systems for which metered data were not available for this hour. For each MCS run the actual performance of each of these systems had to be assigned from an MCS performance distribution. The metered data available for this group of systems appear to provide a good general indication of the distribution of values likely for unmetered systems.

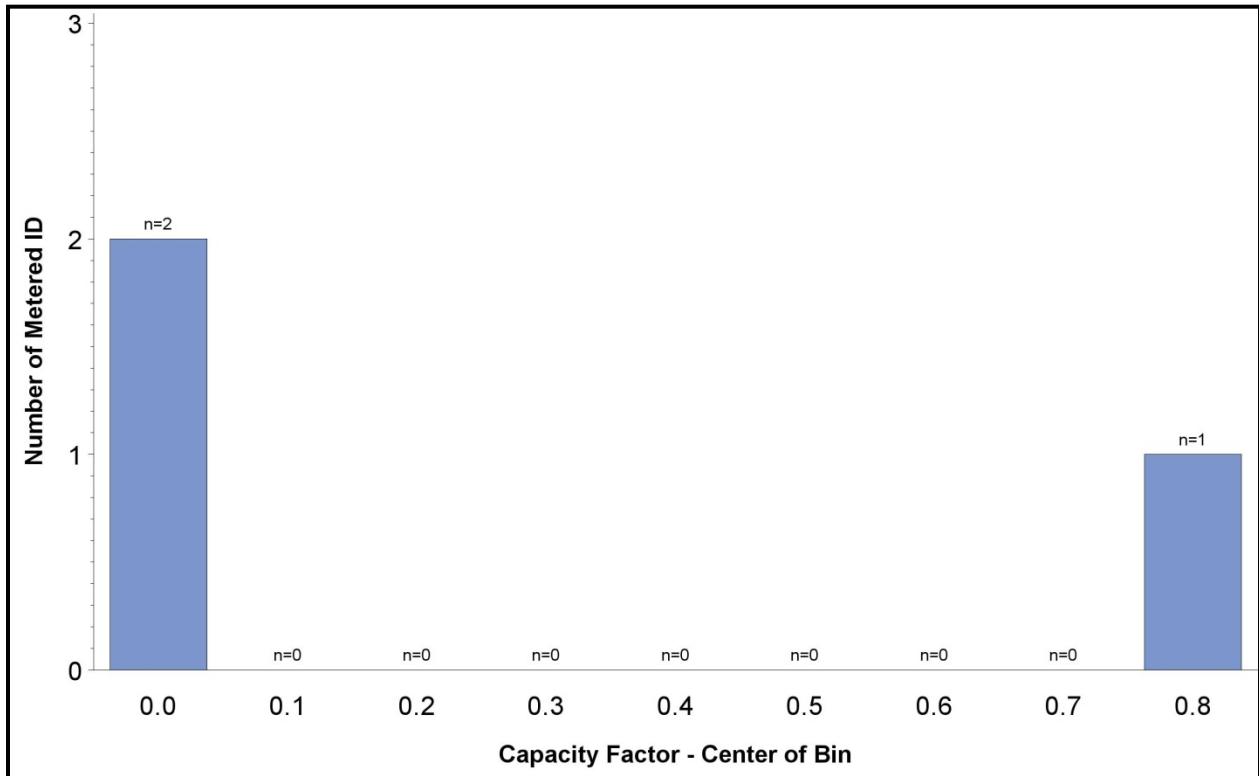
**Figure C-1: Non-Renewable-Fueled Microturbine Measured Coincident Peak Output**



There are other sample design strata for which the quantity of metered data available is insufficient to provide a good indication of the distribution of values likely for unmetered projects. For example, there were only three metered renewable-fueled fuel cells during the CAISO peak hour in 2011. The measured performance of these three systems is shown in Figure C-2.

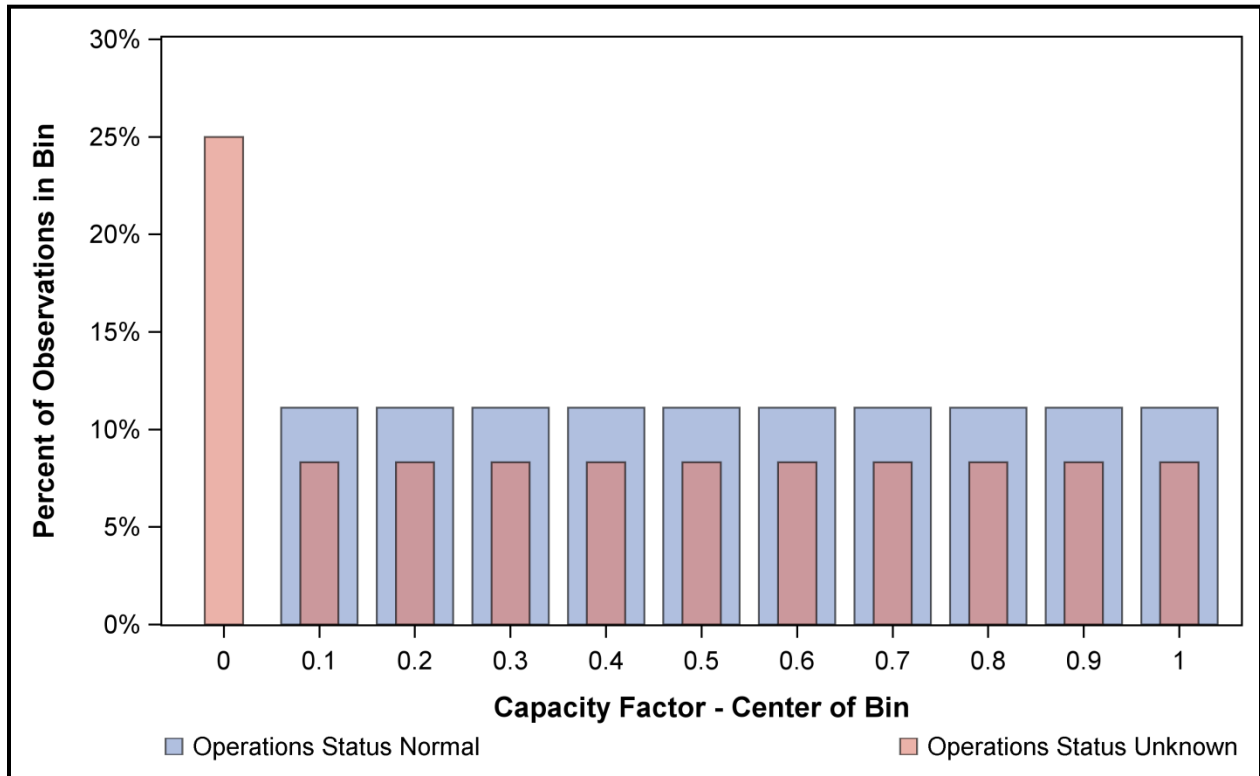


Figure C-2: Renewable-Fueled Fuel Cell Measured Coincident Peak Output



If 10, 24, or 31 systems were metered it is unlikely that all of them would fall in this exact same distribution. Instead some systems would be expected to have a CF of 0.1 and 0.2, and other systems could have been running at full capacity (CF = 1). The metered data available for this group of systems do not appear to provide a good general indication of the distribution of values likely for unmetered systems. Figure C-3 shows the distribution used in the MCS for renewable-fueled fuel cells during the CAISO peak hour.

**Figure C-3: Peak CF Distribution used in MCS for Renewable-Fueled Fuel Cells**



Use of a distribution shown in Figure C-3 emphasizes the fact that the performance of the unmetered systems is not known, and that in the MCS the assumed distribution of peak CF values is based on judgment. Lastly, the modification introduces a small measure of additional conservatism into MCS results. Review of metered data availability for all technology and fuel sample design strata revealed numerous instances such as that described above. Consequently, in some instances simplifying assumptions were made.

Table C-3 shows the groups used to estimate the uncertainty in the CAISO peak hour impact.

**Table C-3: Performance Distributions Developed for the 2010 CAISO Peak Hour MCS Analysis**

<b>Technology</b>	<b>Fuel</b>	<b>PA</b>
Wind <sup>5</sup>	N/A	N/A
IC Engine	Non-renewable, Renewable	All
Microturbine	Non-renewable, Renewable	All
Gas Turbine	Non-renewable <sup>6</sup>	All
Fuel Cell	Non-renewable, Renewable	All

Table C-4 shows the groups used to estimate the uncertainty in the yearly energy production. Internal combustion (IC) engines, gas turbines, and microturbines are grouped together for the uncertainty analysis of the annual energy production because of the small number of systems within each technology group for which data were available for 90% of each month in the year and because a significant difference was not seen between the annual capacity factors of these systems.

**Table C-4: Performance Distributions Developed for the 2010 Annual Energy Production MCS Analysis**

<b>Technology</b>	<b>Fuel</b>
Wind	N/A
Engine/Turbine	Non-renewable, Renewable
Fuel Cell	All

Performance distributions were developed for each of the groups in the tables based on metered data and engineering judgment. In the MCS, a capacity factor is randomly assigned from the performance distribution and sample values are calculated as the product of capacity factor and system size. All of these performance distributions are shown in Figure C-4 through Figure C-27.

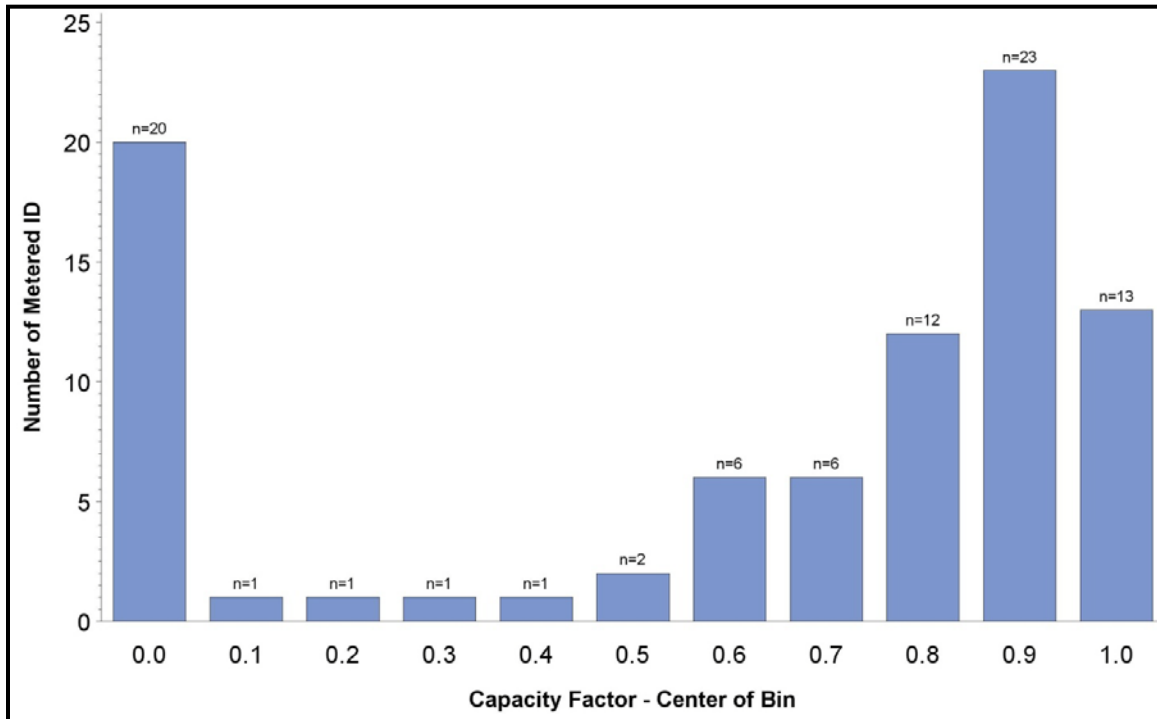
---

<sup>5</sup> As of December 31, 2010, there are eight Complete wind turbine projects in the SGIP. MCS analysis was not conducted for wind turbine impacts due to lack of available metered data.

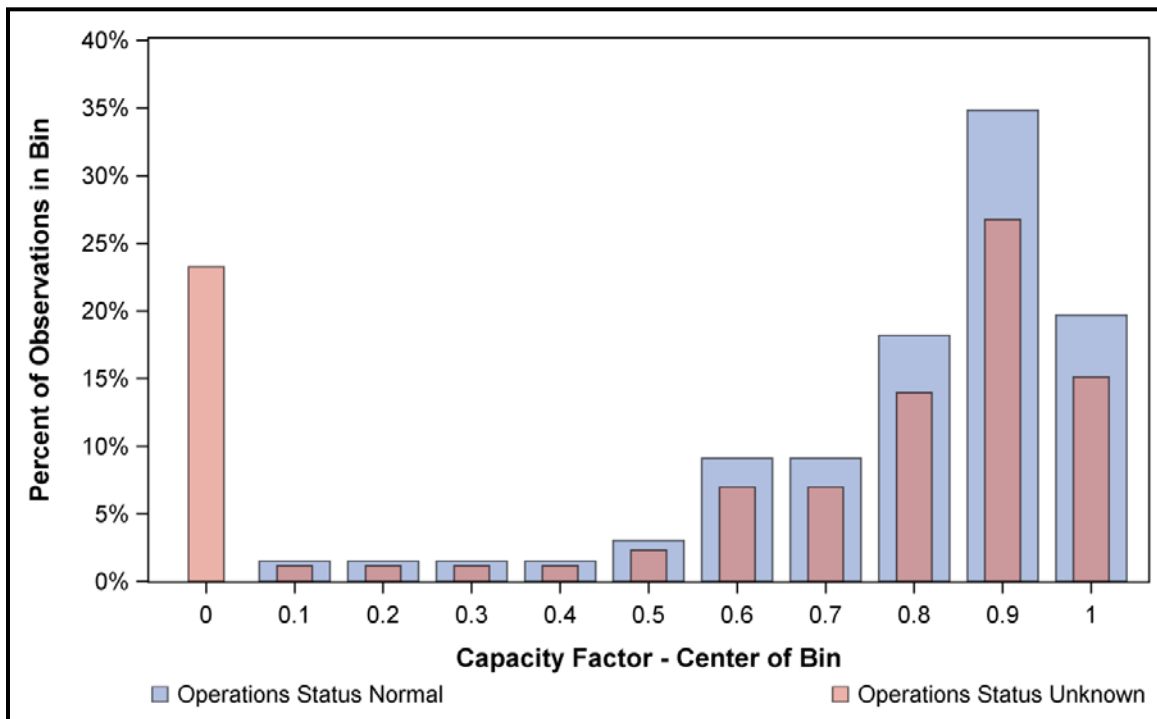
<sup>6</sup> There are no renewable-fueled gas turbines in the program as of December 31, 2010.

*Performance Distributions for Coincident Peak Demand Impacts*

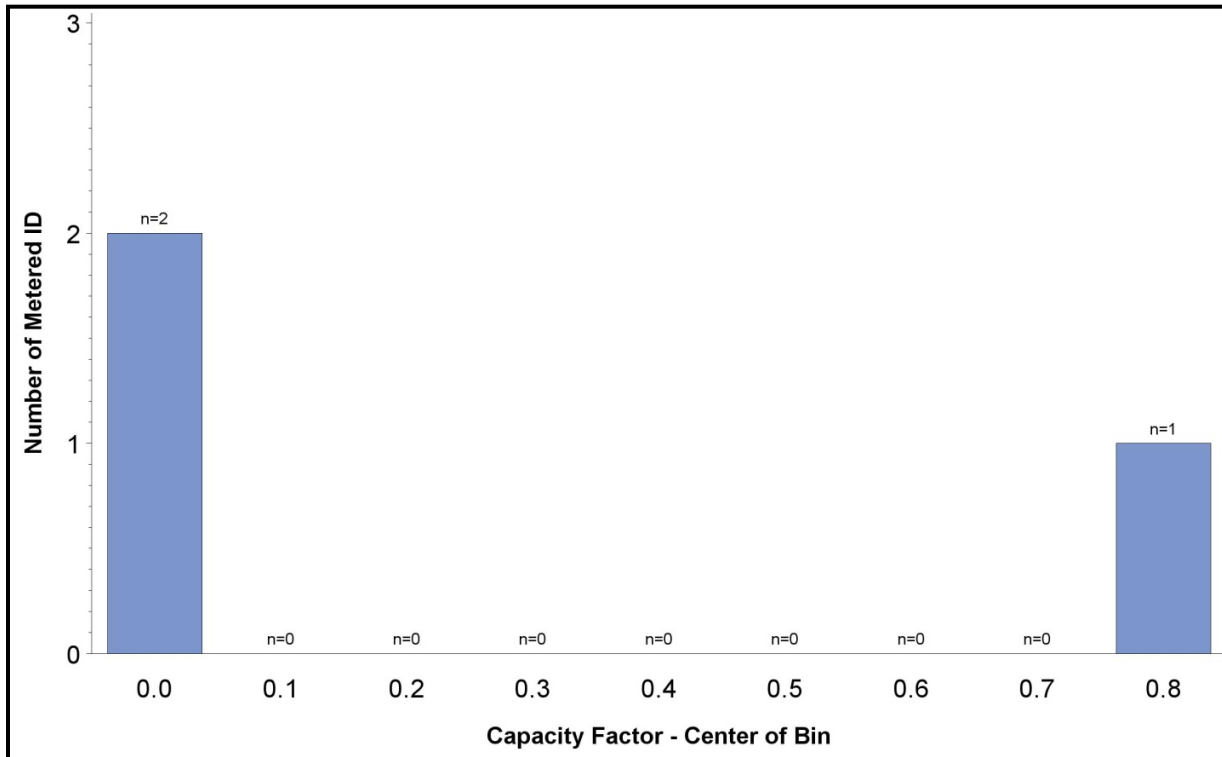
**Figure C-4: Fuel Cell Measured Coincident Peak Output (Non-Renewable Fuel)**



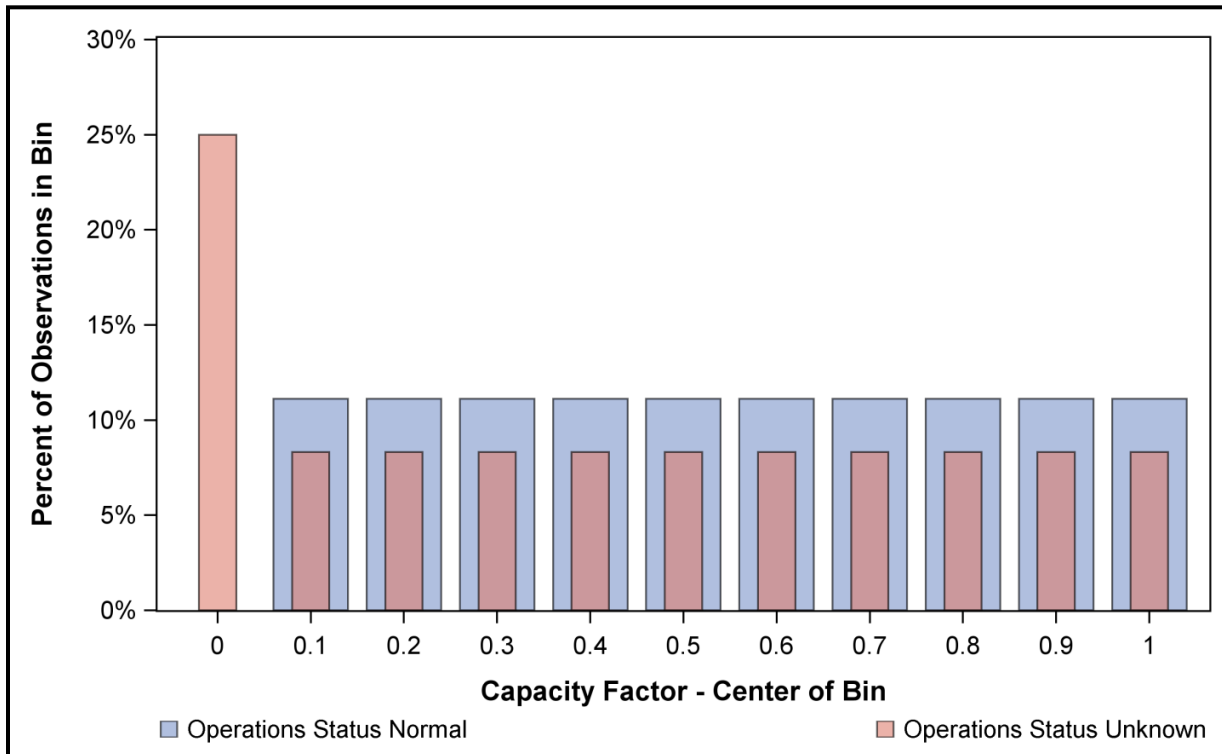
**Figure C-5: MCS Distribution –Fuel Cell Coincident Peak Output (Non-Renewable Fuel)**



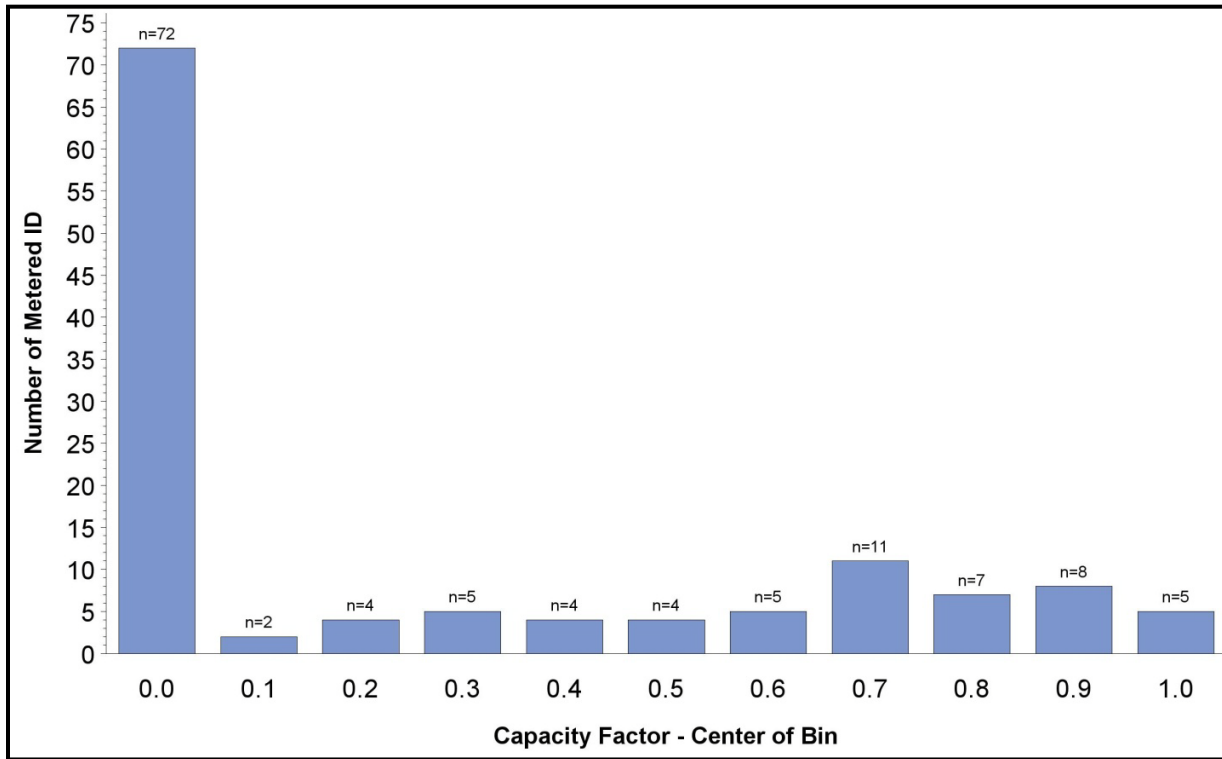
**Figure C-6: Fuel Cell Measured Coincident Peak Output (Renewable Fuel)**



**Figure C-7: MCS Distribution –Fuel Cell Coincident Peak Output (Renewable Fuel)**



**Figure C-8: IC Engine Measured Coincident Peak Output (Non-Renewable Fuel)**



**Figure C-9: MCS Distribution—IC Engine Coincident Peak Output (Non-Renewable Fuel)**

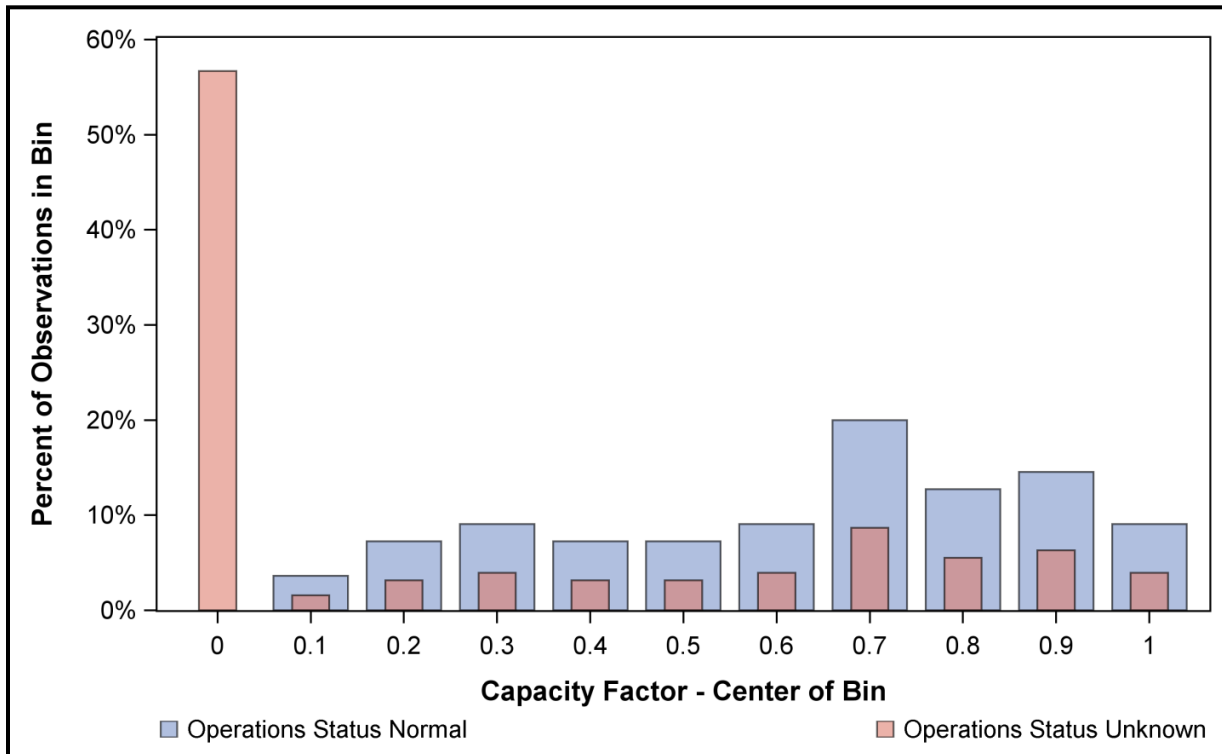


Figure C-10: IC Engine Measured Coincident Peak Output (Renewable Fuel)

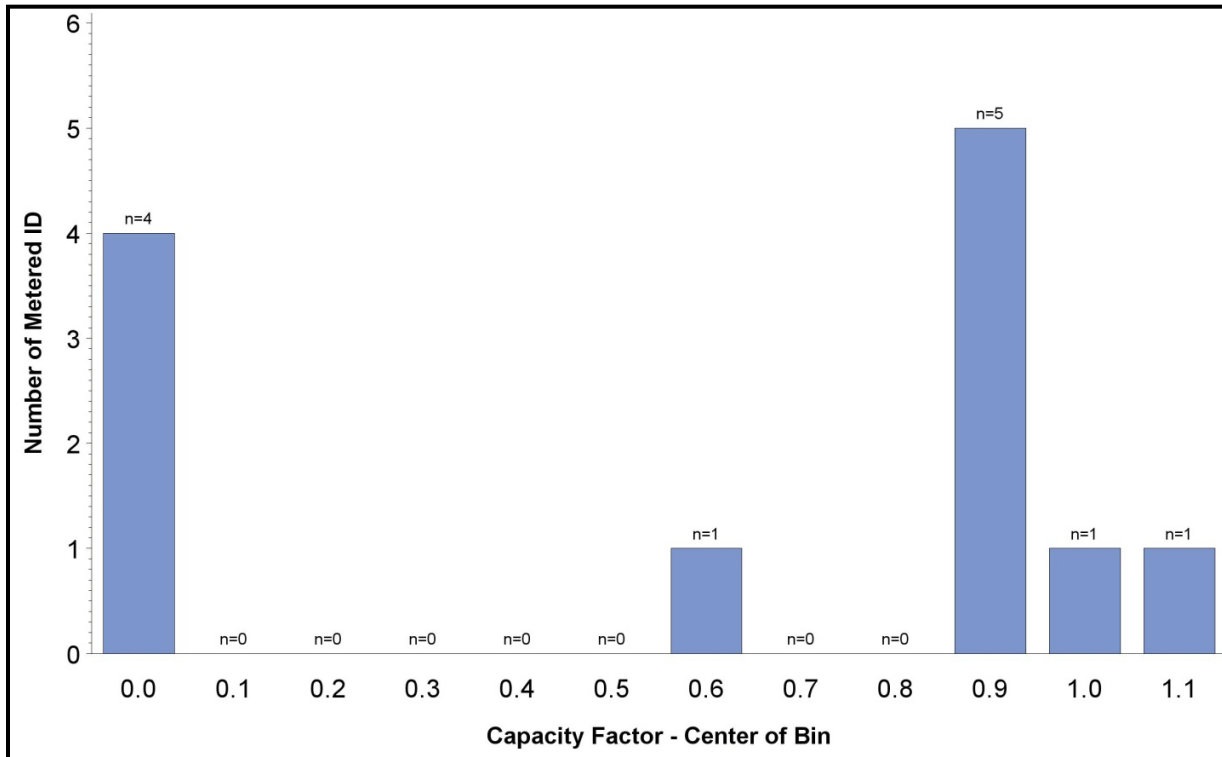
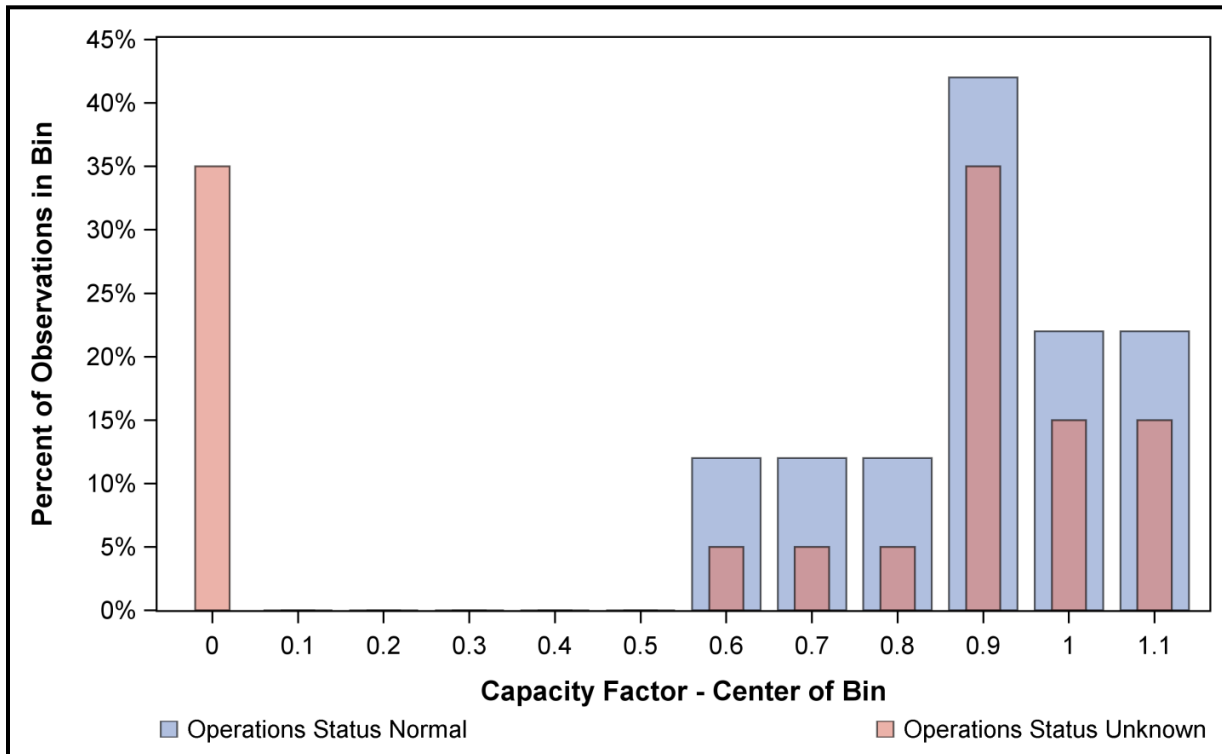
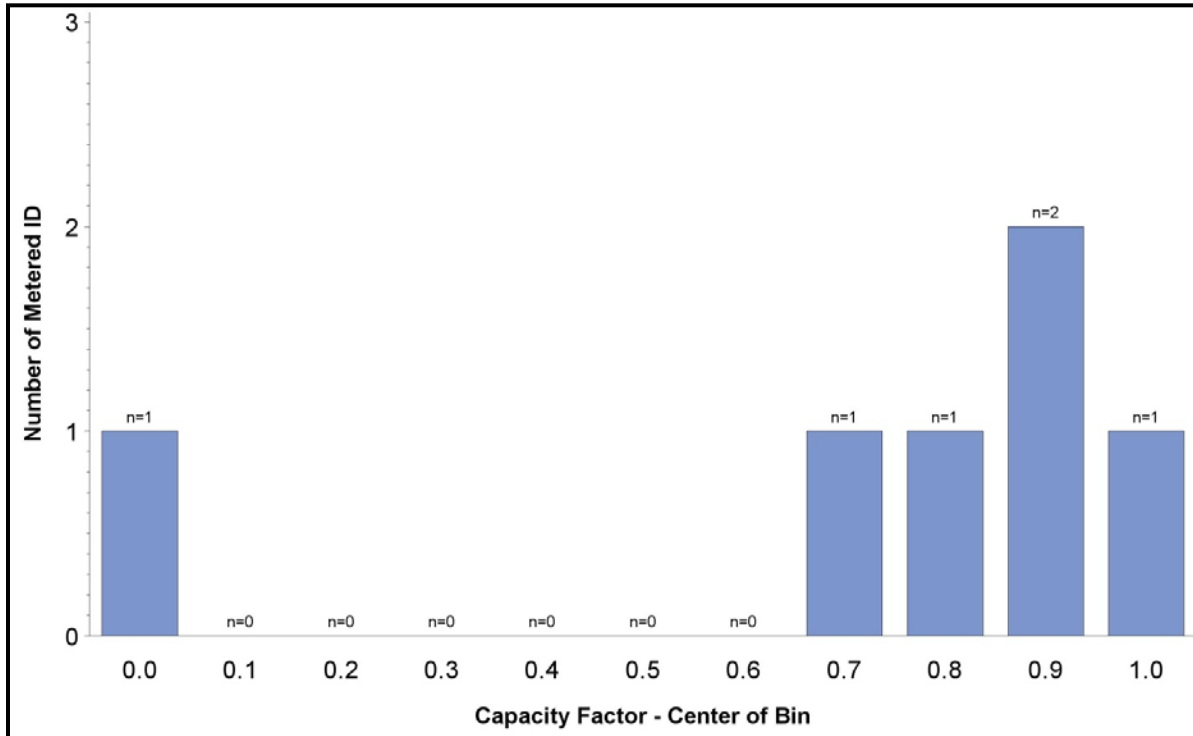


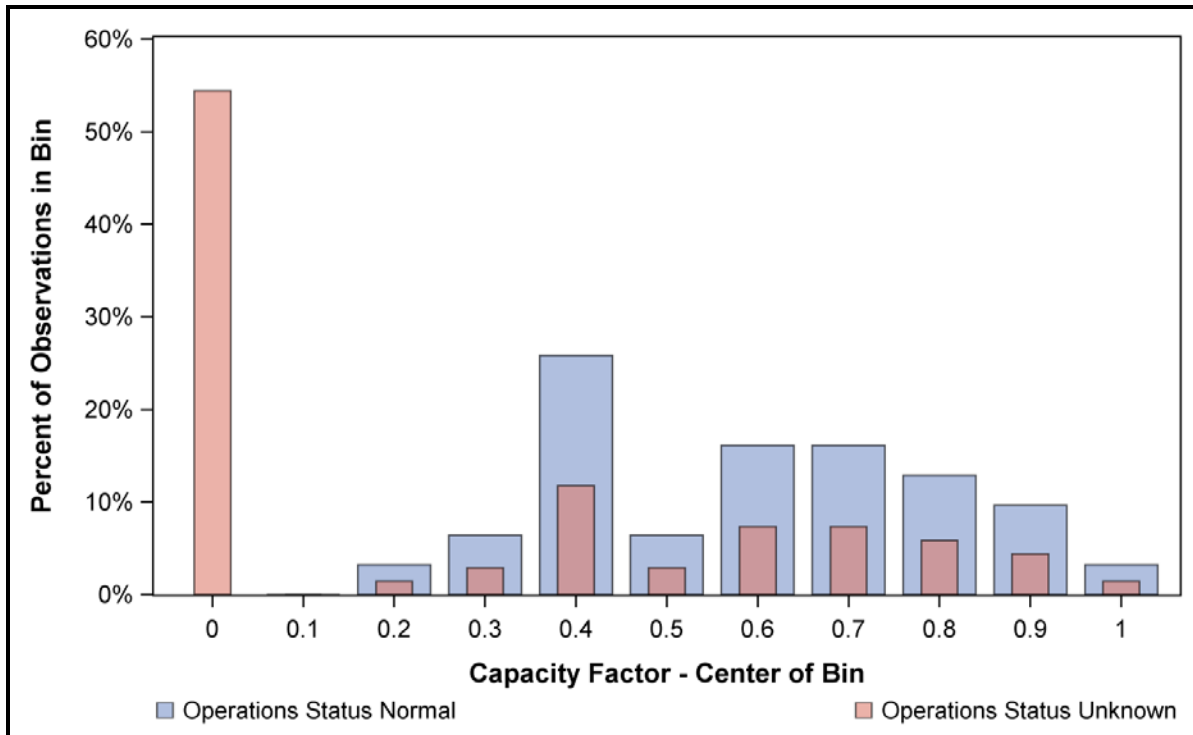
Figure C-11: MCS Distribution—IC Engine Coincident Peak Output (Renewable Fuel)



**Figure C-12: Gas Turbine Measured Coincident Peak Output (Non-Renewable Fuel)**

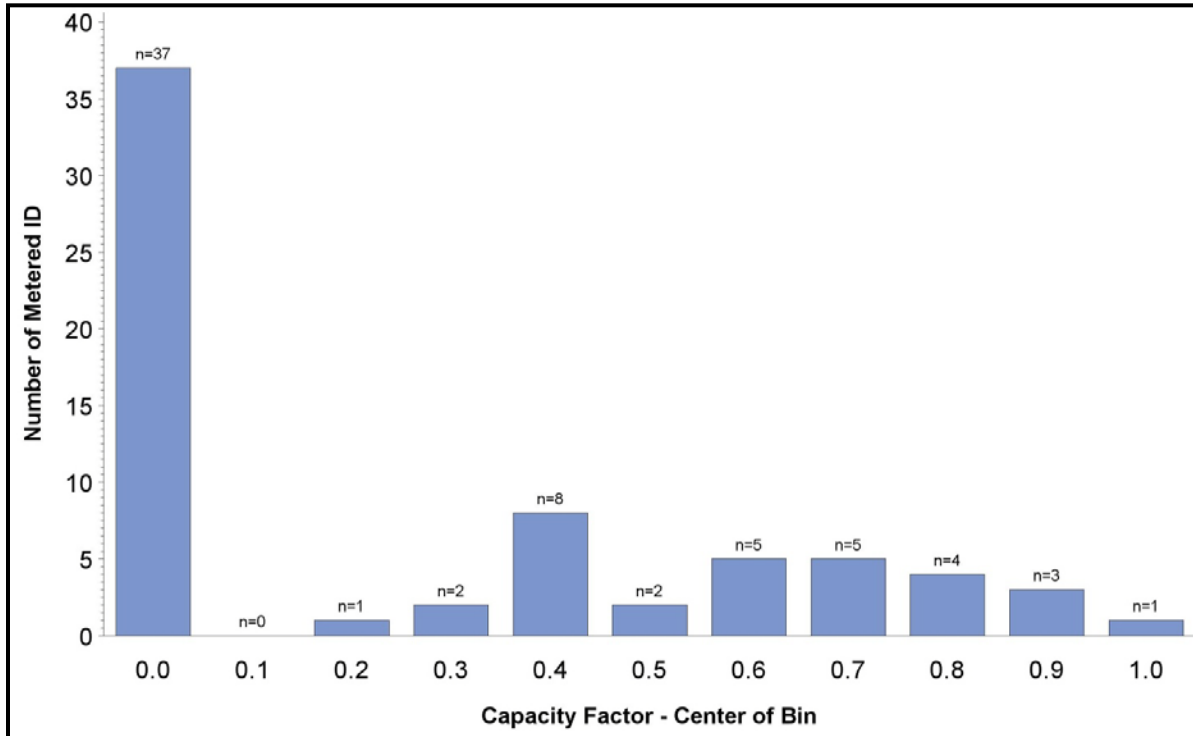


**Figure C-13: MCS Distribution—Gas Turbine Coincident Peak Output (Non-Renewable Fuel)**

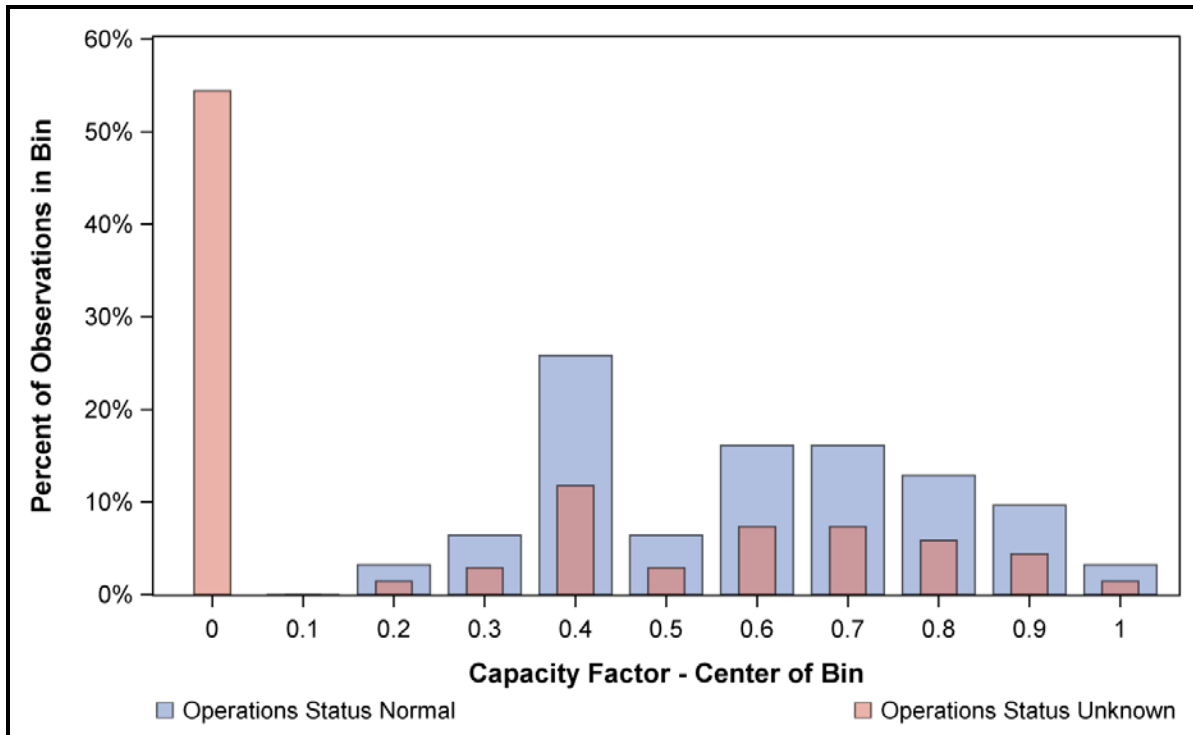




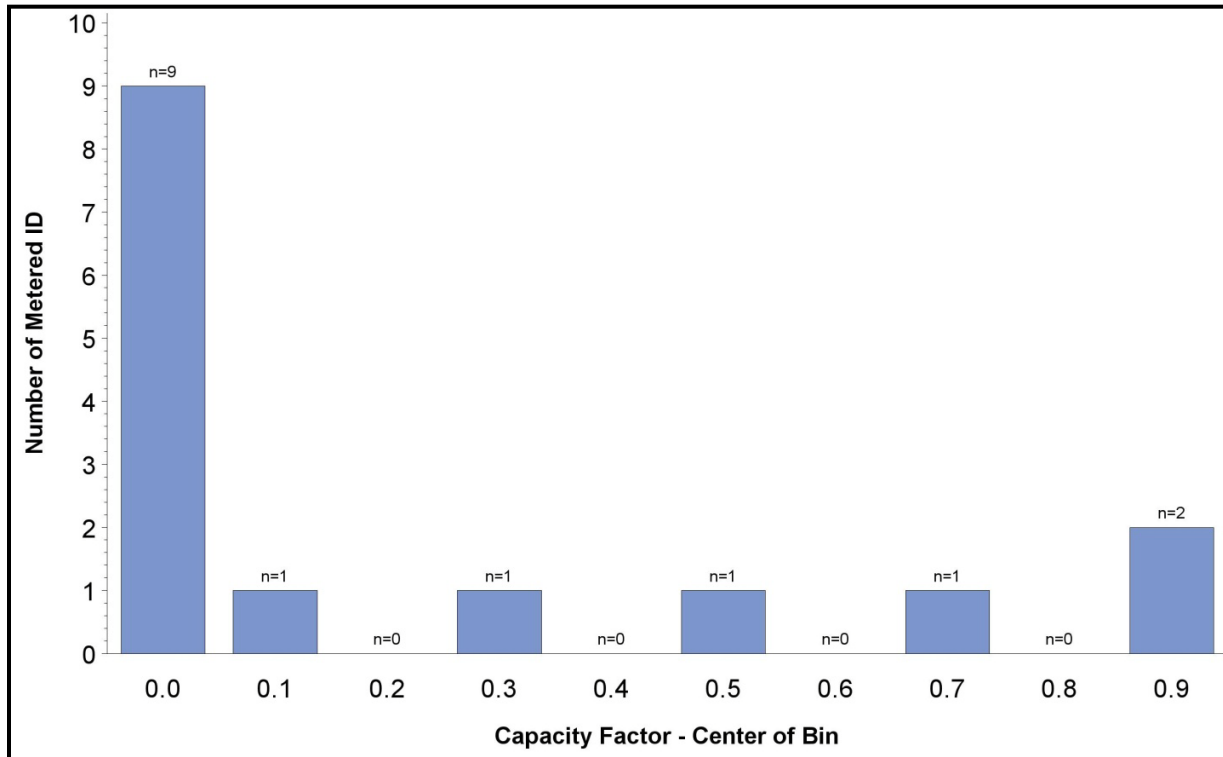
**Figure C-14: Microturbine Measured Coincident Peak Output (Non-Renewable Fuel)**



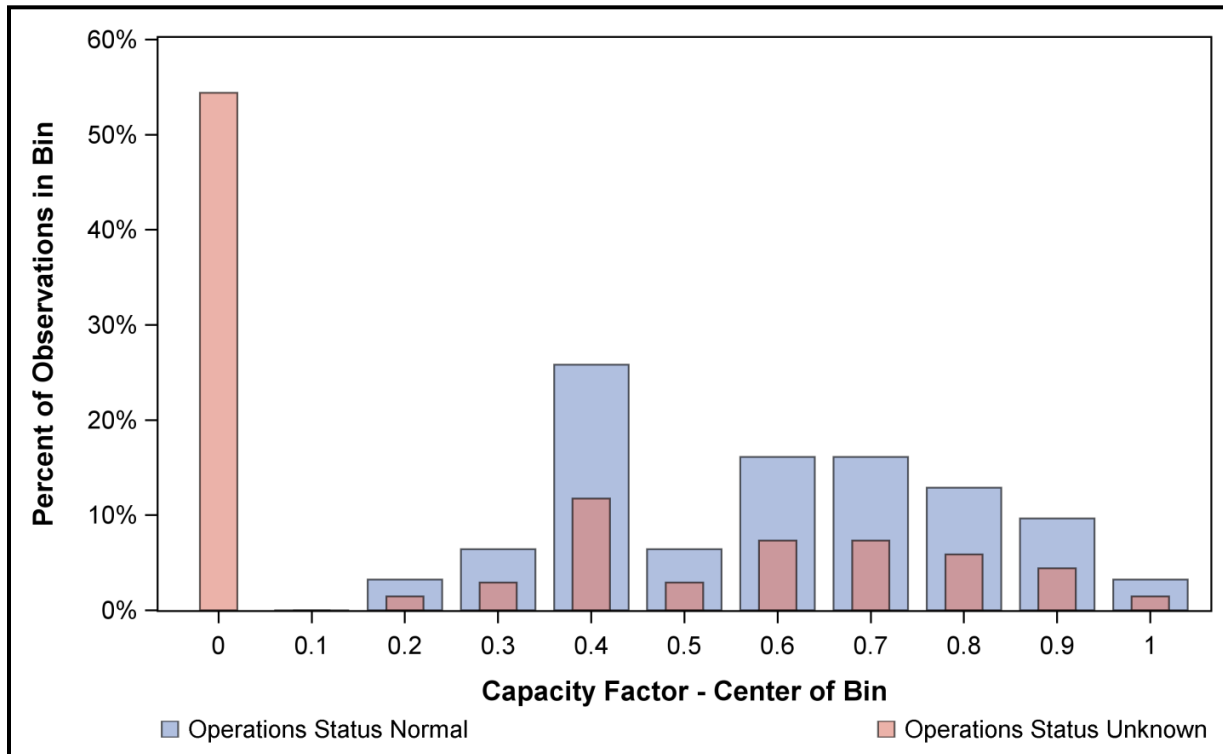
**Figure C-15: MCS Distribution—Microturbine Coincident Peak Output (Non-Renewable Fuel)**



**Figure C-16: Microturbine Measured Coincident Peak Output (Renewable Fuel)**

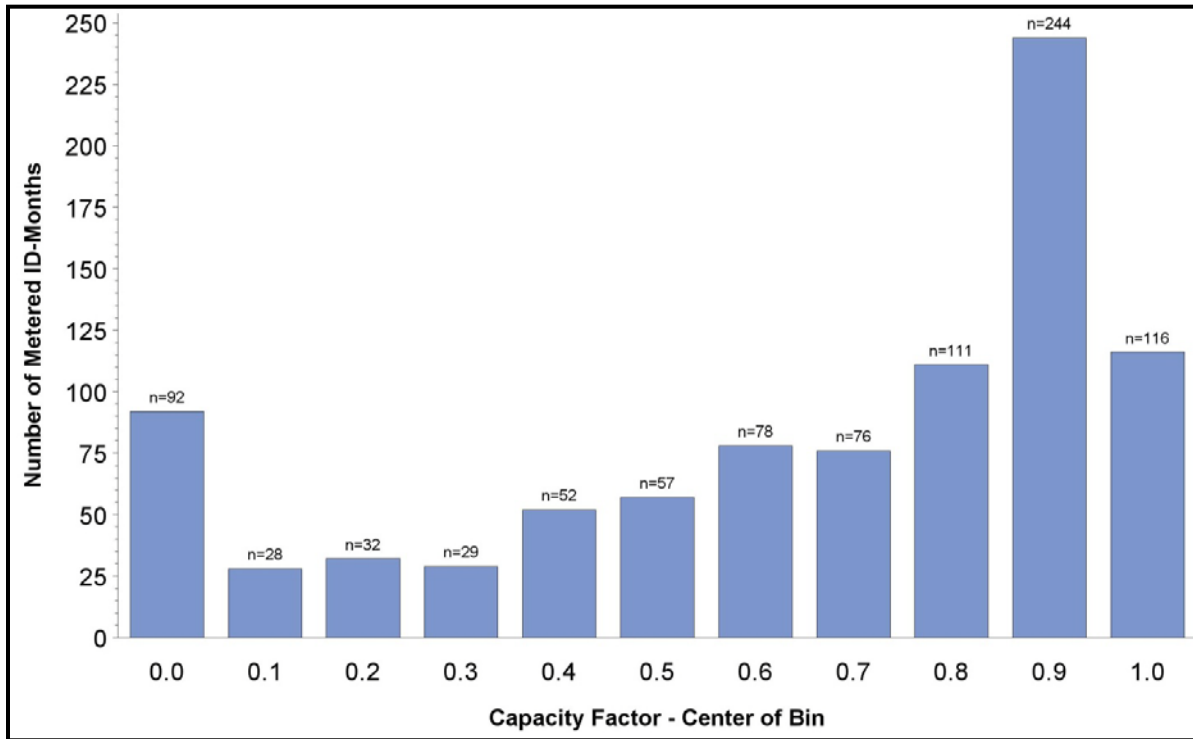


**Figure C-17: MCS Distribution—Microturbine Coincident Peak Output (Renewable Fuel)**

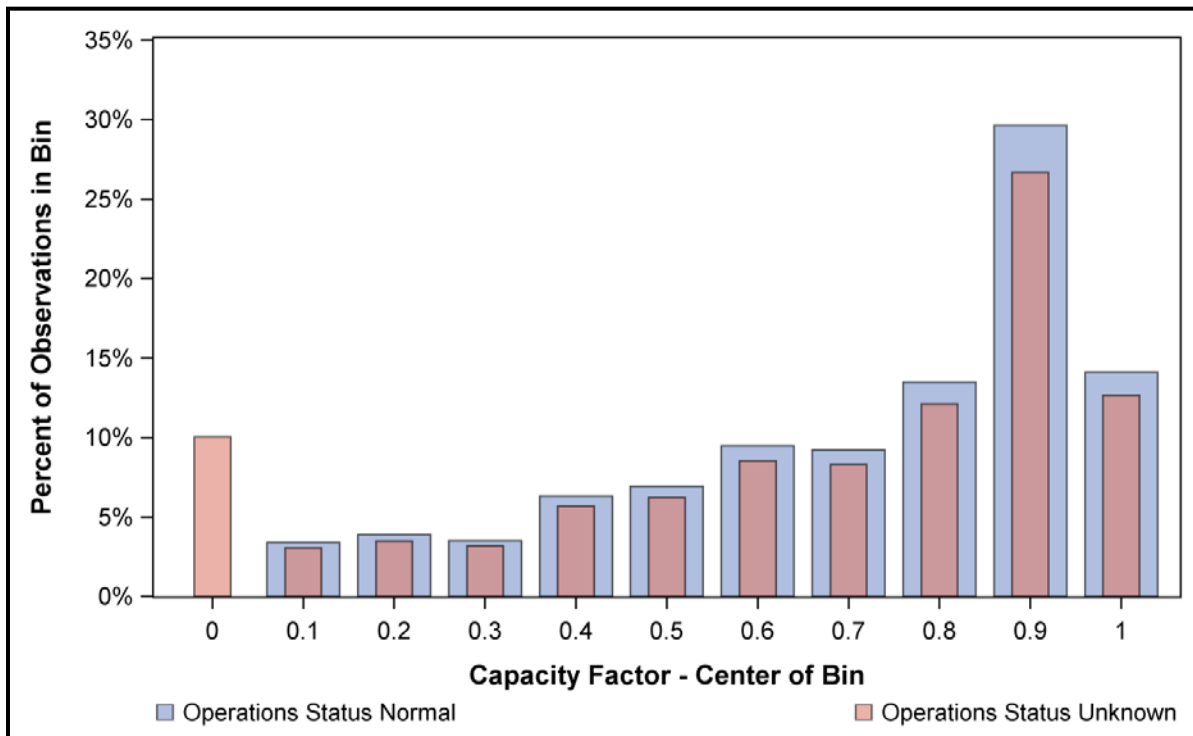


*Performance Distributions for Energy Impacts*

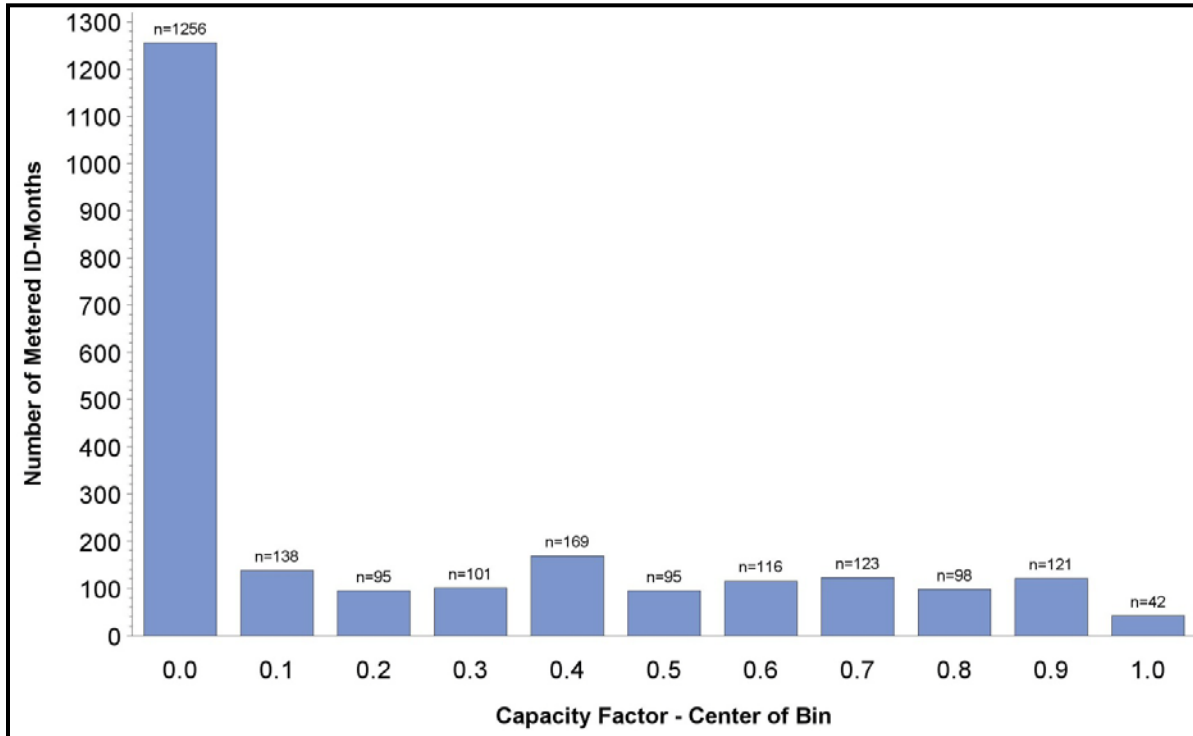
**Figure C-18: Fuel Cell Measured Energy Production (Capacity Factor)**



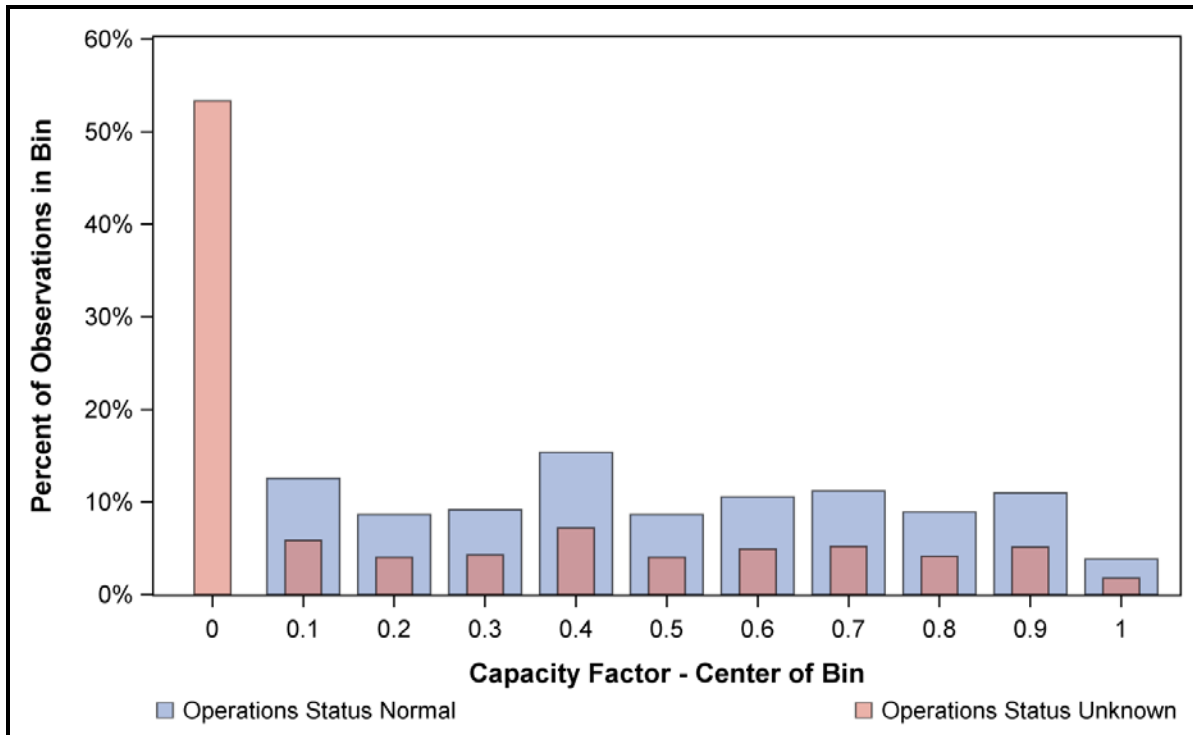
**Figure C-19: MCS Distribution—Fuel Cell Energy Production (Capacity Factor)**



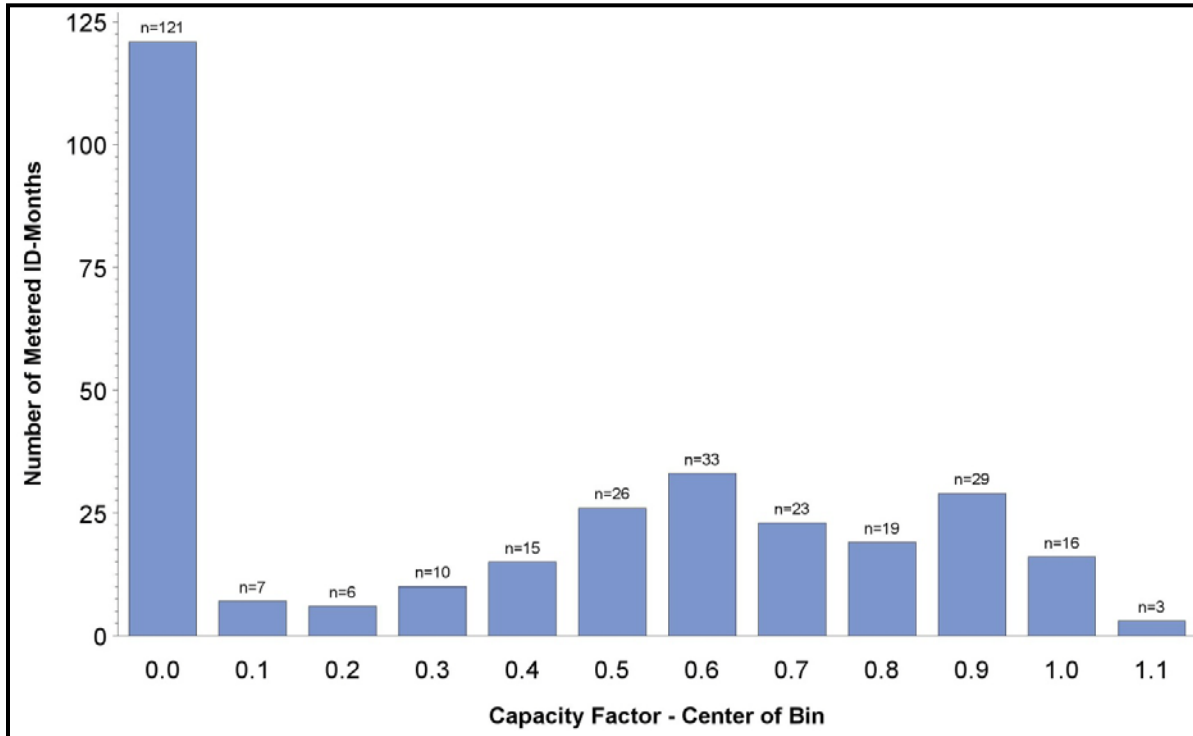
**Figure C-20: Engine/Turbine (Non-Renewable) Measured Electricity Production (Capacity Factor)**



**Figure C-21: MCS Distribution—Engine/Turbine (Non-Renewable) Electricity Production (Capacity Factor)**



**Figure C-22: Engine/Turbine (Renewable) Measured Electricity Production (Capacity Factor)**



**Figure C-23: MCS Distribution—Engine/Turbine (Renewable) Electricity Production (Capacity Factor)**

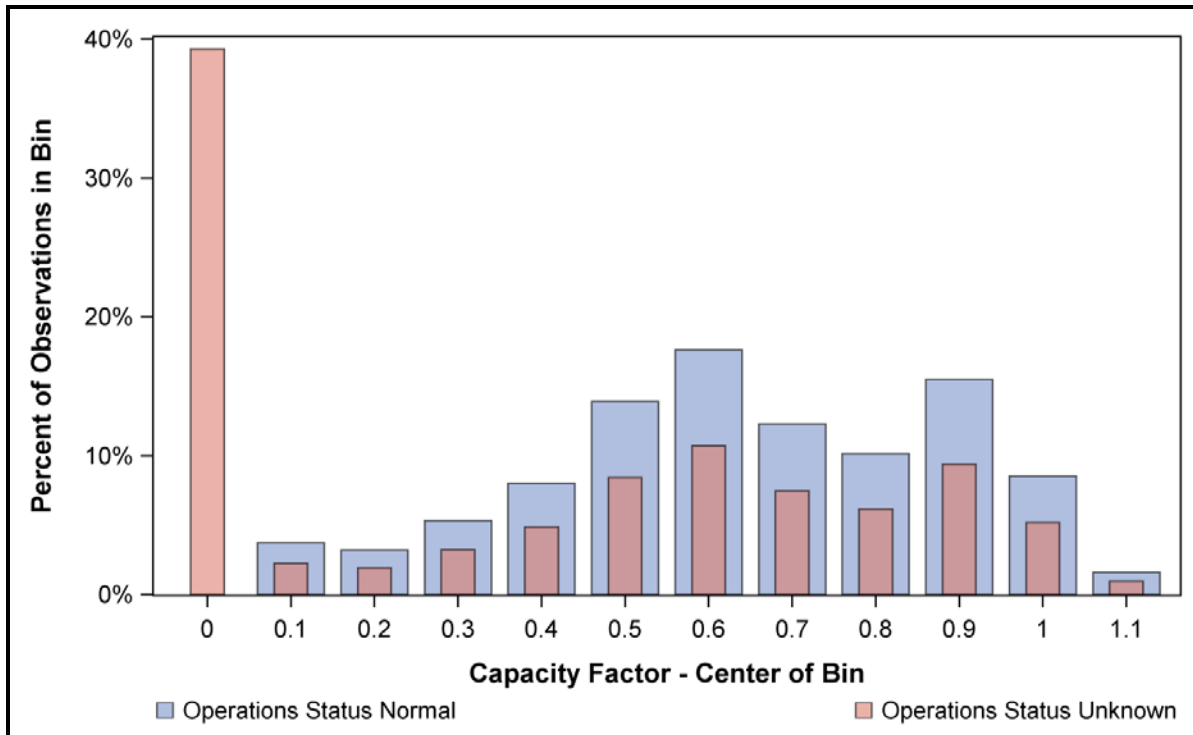


Figure C-24: Fuel Cell (Non-Renewable) Measured Heat Recovery Rate

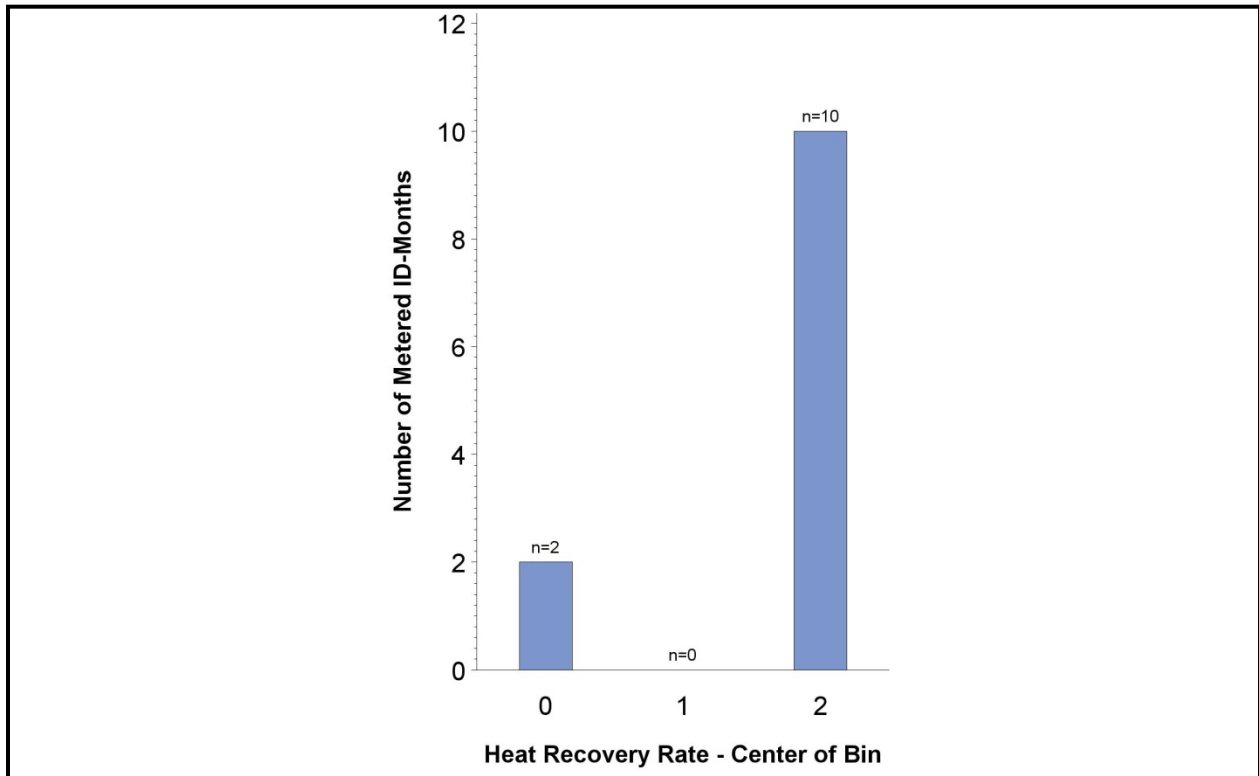
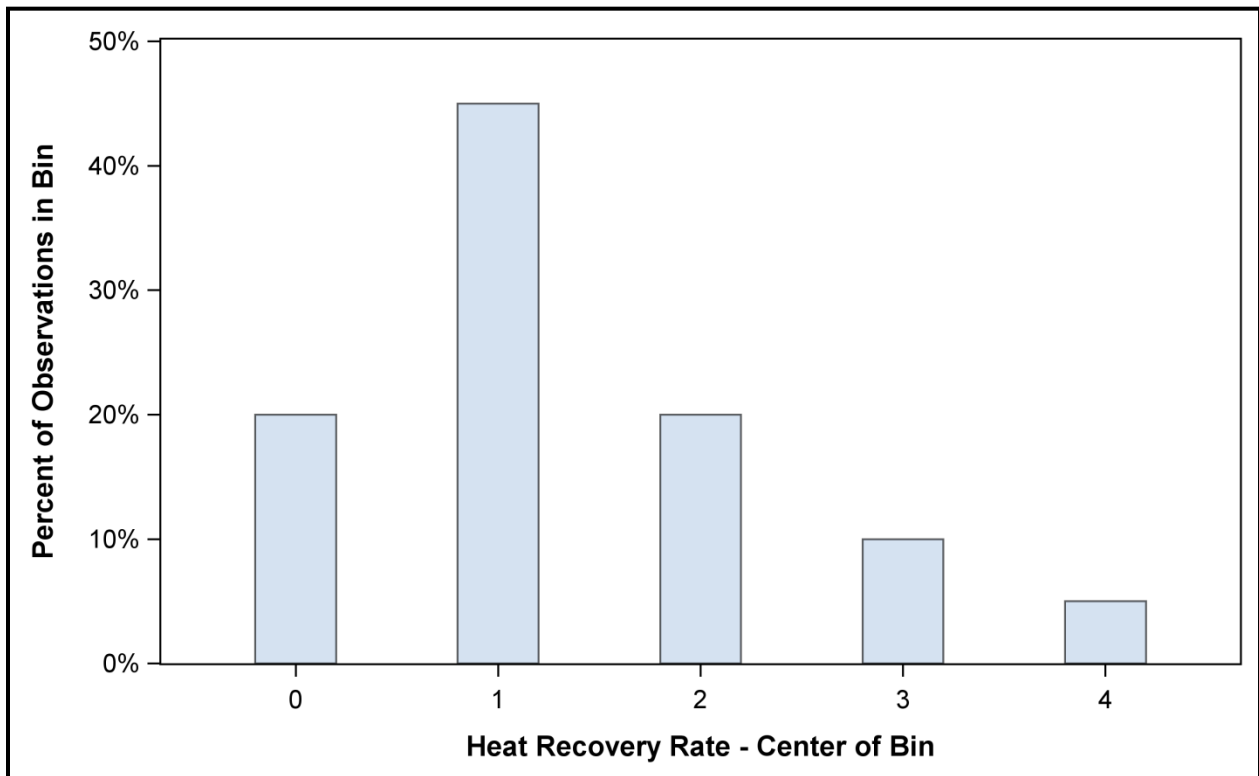
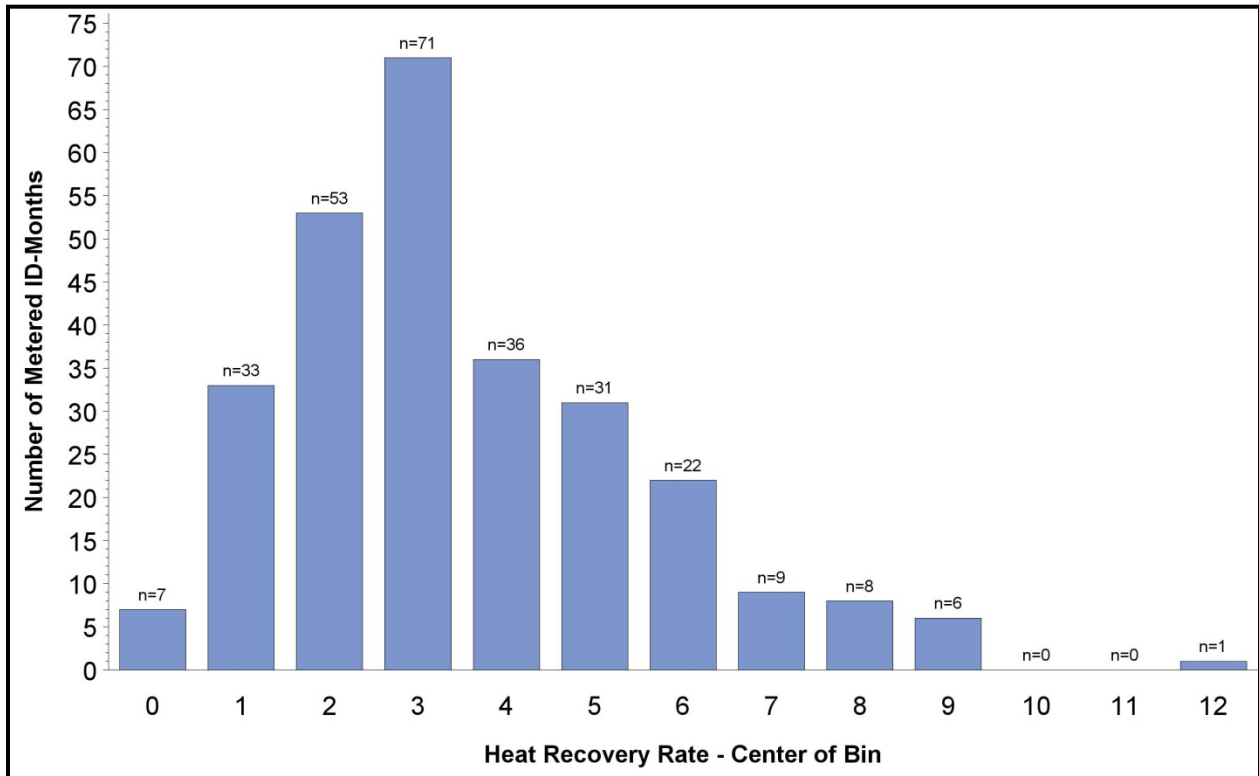


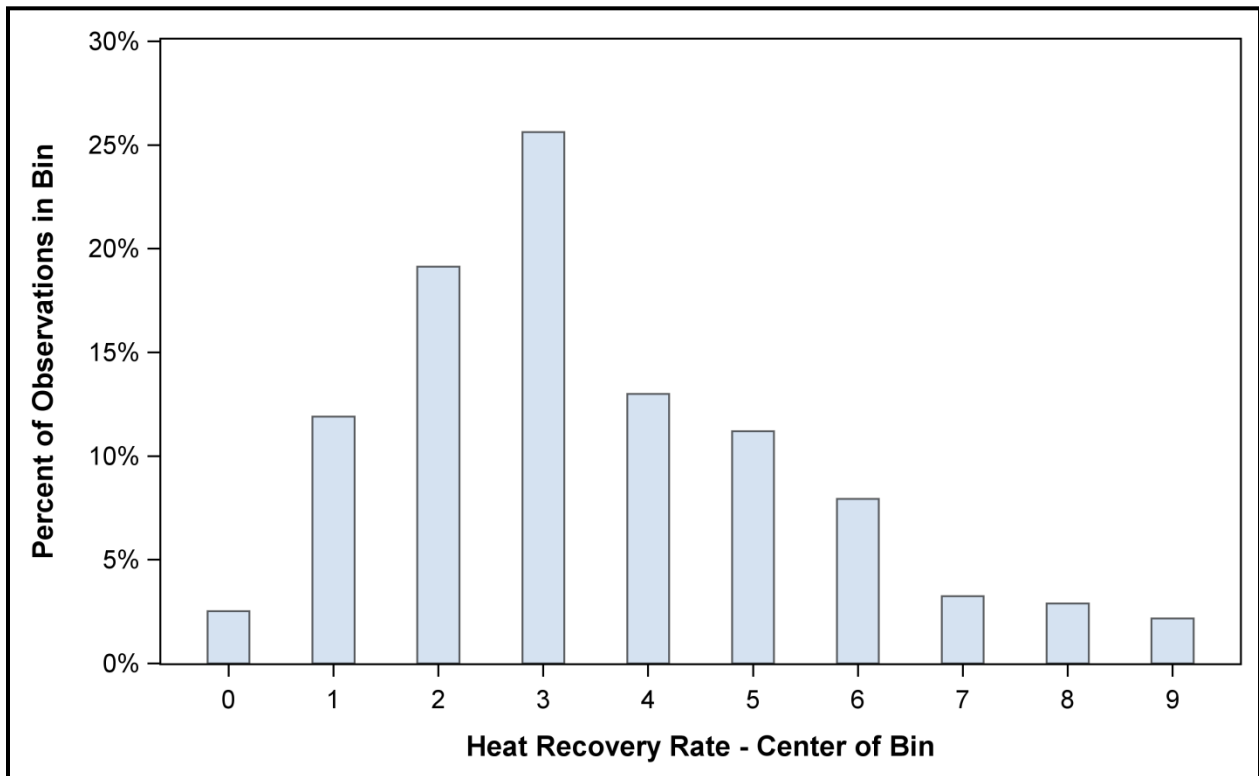
Figure C-25: MCS Distribution—Fuel Cell (Non-Renewable) Heat Recovery Rate



**Figure C-26: Engine/Turbine Measured Heat Recovery Rate**



**Figure C-27: MCS Distribution—Engine/Turbine Heat Recovery Rate**



*Bias*

Performance data collected from metered sites were used to estimate program impacts attributable to unmetered sites. If the metered sites are not representative of the unmetered sites then those estimates will include systematic error called bias. Potential sources of bias of principle concern for this study include:

***Planned data collection disproportionately favors dissimilar groups.*** HEAT metering is generally being installed on projects which are still under their three-year contract (or five-year contract for fuel cells) with SGIP. If the actual heat recovery performance of the older systems differs systematically from the newer metered systems then estimates calculated for the older systems will be biased. A similar situation can occur when actual performance differs substantially from performance assumptions underlying data collection plans.

***Actual data collection allocations deviate from planned data collection allocations.*** In program impact evaluation studies, actual data collection almost invariably deviates somewhat from planned data collection. If the deviation is systematic rather than random then estimates calculated for unmetered systems may be biased. For example, metered data for a number of fuel cell systems are received from their hosts or the fuel cell manufacturer. The result is a metered dataset that may contain a disproportionate quantity of data received from program participants who operate their own metering. This metered dataset is used to calculate impacts for unmetered sites. If the actual performance of the unmetered systems differs systematically from that of the systems metered by participants then estimates calculated for the unmetered systems will be biased. One example of this is if a participant metered system's output decreases unexpectedly the participant will know almost immediately and steps can be taken to get the system running normally again. However, a similar situation with an unmetered system could go unnoticed for months.

***Actual data collection quantities deviate from planned data collection quantities.*** For example, plans called for collection of ENGO data from all RFU systems; however, data were actually collected only from a small proportion of completed RFU systems.

In the MCS analysis bias is accounted for during development of performance distributions assumed for unmetered systems. If the metered sample is thought to be biased then engineering judgment dictates specification of a relatively 'more spread out' performance distribution. Bias is accounted for, but the accounting does not involve adjustment of point estimates of program impacts. If engineering judgment dictates an accounting for bias then the performance distribution assumed for the MCS analysis has a higher standard deviation. The result is a larger confidence interval about the reported point estimate. If there is good reason to believe that bias could be substantial, the confidence interval reported for the point estimate will be larger.



To this point the discussion of bias has been limited to sampling bias. More generally, bias can also be the result of instrumentation yielding measurements that are not representative of the actual parameters being monitored. Due to the wide variety of instrumentation types and data providers involved with this project it is not possible to say one way or the other whether or not instrumentation bias contributes to error in impacts reported for either metered or unmetered sites. Due to the relative magnitudes involved, instrumentation error—if it exists—accounts for an insignificant portion or total bias contained in point estimates.

It is important to note that possible sampling bias affects only impacts estimates calculated for unmetered sites. The relative importance of this varies with metering rate. For example, where the metering rate is 90%, a 20% sampling bias will yield an error of only 2% in total (metered + unmetered) program impacts. All else equal, higher metering rates reduce the impact of sampling bias on estimates of total program impacts.

**Calculate the Quantities of Interest for Each Sample**

After each simulation run the resulting sample data for individual sites are summed to the program level and the result is saved. The quantities of interest were defined previously:

- Program Total Annual Electrical Energy Impacts
- Program Total Coincident Peak Electrical Demand Impacts
- Program Total PUC216.6 (b) Cogeneration System Efficiency

Cogeneration system efficiency is a calculated value that is based on sample data for electricity production, fuel consumption, and heat recovery. The efficiency values for each simulation run were calculated as:

$$PUC216.6b_r = \frac{\left( \sum ELEC_{rs} \times KWH2KBTU \right) + \left( \sum CI \times HEAT_{rs} \right)}{\sum FUEL_{rs}} \times \frac{100\%}{1}$$

Where:

*PUC216.6b<sub>r</sub>* is program total PUC216.6 (b) cogeneration system efficiency for run *r*

Units: %

*ELEC<sub>rs</sub>* is total electricity production for run *r* and system *s*

Units: kWh

KWH2KBTU is a conversion factor

Value: 0.2931 (i.e., 1/3.412)

Units: kWh/kBtu

C1 is a constant

Value: 0.5

Units: none

Basis: Cogeneration system efficiency definition of CPUC

$HEAT_{rs}$  is total useful waste heat recovery for run  $r$  and system  $s$

Units: kBtu

$FUEL_{rs}$  is total fuel consumption for run  $r$  and system  $s$

Units: kBtu

Basis: Lower Heating Value of fuel

### **Analyze Accumulated Quantities of Interest**

The pools of accumulated MCS analysis results are analyzed to yield summary information about their central tendency and variability. Mean values are calculated and the variability exhibited by the values for the many runs is examined to determine confidence levels (under the constraint of constant relative precision), or to determine confidence intervals (under the constraint of constant confidence level).

#### **C.4.5 Results**

The confidence levels in the energy impacts, demand impacts, and PUC 216.6 compliance results have been presented along with those results. This section will present the precision and confidence intervals associated with those confidence levels in more detail. Three bins were used for Confidence Levels: 90/10 or better, 70/30 or better (but worse than 90/10), and worse than 70/30.

**Table C-5: Uncertainty Analysis Results for Annual Energy Impact Results by Technology and Basis**

<b>Technology* / Basis</b>	<b>Confidence Level</b>	<b>Precision<sup>†</sup></b>	<b>Confidence Interval<sup>†</sup></b>
<b>FC</b>	<b>90%</b>	<b>2.26%</b>	<b>0.642 to 0.672</b>
Metered	90%	0.03%	0.660 to 0.661
Estimated	90%	5.84%	0.614 to 0.690
<b>GT</b>	<b>90%</b>	<b>1.92%</b>	<b>0.749 to 0.779</b>
Metered	90%	0.06%	0.827 to 0.828
Estimated	70%	19.7%	0.283 to 0.422
<b>IC Engine</b>	<b>90%</b>	<b>3.13%</b>	<b>0.236 to 0.252</b>
Metered	90%	0.02%	0.191 to 0.191
Estimated	90%	6.12%	0.312 to 0.352
<b>MT</b>	<b>90%</b>	<b>2.80%</b>	<b>0.309 to 0.327</b>
Metered	90%	0.03%	0.320 to 0.320
Estimated	70%	6.6%	0.291 to 0.332

\* FC = Fuel Cell; GT = Gas Turbine; IC Engine = Internal Combustion Engine; MT = Microturbine

<sup>†</sup> Both precision and confidence interval are given according to the corresponding confidence level. In cases where an accuracy level of 90% confidence and 10% precision (i.e., 90/10) was not achieved the reported precision values and confidence intervals are based on a 70% confidence level.

**Table C-6: Uncertainty Analysis Results for Annual Energy Impact Results by Technology, Fuel, and Basis**

<b>Technology* &amp; Fuel/ Basis</b>	<b>Confidence Level</b>	<b>Precision<sup>†</sup></b>	<b>Confidence Interval<sup>†</sup></b>
<b>FC-N</b>	<b>90%</b>	<b>2.08%</b>	<b>0.671 to 0.699</b>
Metered	90%	0.03%	0.699 to 0.699
Estimated	90%	7.53%	0.602 to 0.700
<b>FC-R</b>	<b>90%</b>	<b>7.88%</b>	<b>0.515 to 0.604</b>
Metered	90%	0.16%	0.299 to 0.300
Estimated	90%	9.18%	0.592 to 0.712
<b>GT-N</b>	<b>90%</b>	<b>1.92%</b>	<b>0.749 to 0.779</b>
Metered	90%	0.06%	0.827 to 0.828
Estimated	70%	19.7%	0.283 to 0.422
<b>IC Engine-N</b>	<b>90%</b>	<b>3.62%</b>	<b>0.216 to 0.232</b>
Metered	90%	0.03%	0.165 to 0.165
Estimated	90%	6.67%	0.299 to 0.342
<b>IC Engine-R</b>	<b>90%</b>	<b>5.86%</b>	<b>0.402 to 0.452</b>
Metered	90%	0.05%	0.419 to 0.419
Estimated	70%	10.4%	0.397 to 0.489
<b>MT-N</b>	<b>90%</b>	<b>3.04%</b>	<b>0.327 to 0.348</b>
Metered	90%	0.04%	0.354 to 0.355
Estimated	70%	7.7%	0.272 to 0.317
<b>MT-R</b>	<b>90%</b>	<b>7.14%</b>	<b>0.215 to 0.248</b>
Metered	90%	0.07%	0.186 to 0.186
Estimated	70%	13.1%	0.374 to 0.486

\* FC = Fuel Cell; GT = Gas Turbine; IC Engine = Internal Combustion Engine; MT = Microturbine; N = Non-Renewable; R = Renewable

† Both precision and confidence interval are given according to the corresponding confidence level. In cases where an accuracy level of 90% confidence and 10% precision (i.e., 90/10) was not achieved the reported precision values and confidence intervals are based on a 70% confidence level.

**Table C-7: Uncertainty Analysis Results for PG&E Annual Energy Impact**

Technology / Basis	Confidence Level	Precision*	Confidence Interval*
<b>FC</b>	<b>90%</b>	<b>2.7%</b>	<b>0.702 to 0.741</b>
Metered	90%	0.0%	0.757 to 0.757
Estimated	90%	8.8%	0.593 to 0.708
<b>GT</b>	<b>70%</b>	<b>16.5%</b>	<b>0.212 to 0.296</b>
Metered	90%	0.0%	0.000 to 0.000
Estimated	70%	16.5%	0.324 to 0.451
<b>IC Engine</b>	<b>90%</b>	<b>5.4%</b>	<b>0.249 to 0.278</b>
Metered	90%	0.0%	0.200 to 0.200
Estimated	90%	9.2%	0.309 to 0.372
<b>MT</b>	<b>90%</b>	<b>4.4%</b>	<b>0.377 to 0.412</b>
Metered	90%	0.0%	0.433 to 0.433
Estimated	70%	9.0%	0.300 to 0.359

\* Both precision and confidence interval are given according to the corresponding confidence level. In cases where an accuracy level of 90% confidence and 10% precision (i.e., 90/10) was not achieved the reported precision values and confidence intervals are based on a 70% confidence level.

**Table C-8: Uncertainty Analysis Results for SCE Annual Energy Impact**

Technology / Basis	Confidence Level	Precision*	Confidence Interval*
<b>FC</b>	<b>90%</b>	<b>6.4%</b>	<b>0.571 to 0.649</b>
Metered	90%	0.1%	0.545 to 0.546
Estimated	70%	6.5%	0.616 to 0.701
<b>IC Engine</b>	<b>90%</b>	<b>7.7%</b>	<b>0.198 to 0.231</b>
Metered	90%	0.0%	0.146 to 0.146
Estimated	70%	8.4%	0.296 to 0.350
<b>MT</b>	<b>90%</b>	<b>8.7%</b>	<b>0.175 to 0.208</b>
Metered	90%	0.1%	0.160 to 0.160
Estimated	70%	14.4%	0.238 to 0.318

\* Both precision and confidence interval are given according to the corresponding confidence level. In cases where an accuracy level of 90% confidence and 10% precision (i.e., 90/10) was not achieved the reported precision values and confidence intervals are based on a 70% confidence level.

**Table C-9: Uncertainty Analysis Results for SCG Annual Energy Impact**

<b>Technology / Basis</b>	<b>Confidence Level</b>	<b>Precision*</b>	<b>Confidence Interval*</b>
<b>FC</b>	<b>90%</b>	<b>6.1%</b>	<b>0.606 to 0.685</b>
Metered	90%	0.1%	0.647 to 0.648
Estimated	70%	8.2%	0.594 to 0.699
<b>GT</b>	<b>90%</b>	<b>2.6%</b>	<b>0.771 to 0.813</b>
Metered	90%	0.1%	0.828 to 0.830
Estimated	70%	86.8%	0.033 to 0.467
<b>IC Engine</b>	<b>90%</b>	<b>4.8%</b>	<b>0.248 to 0.273</b>
Metered	90%	0.0%	0.225 to 0.225
Estimated	70%	6.9%	0.302 to 0.346
<b>MT</b>	<b>90%</b>	<b>2.6%</b>	<b>0.325 to 0.342</b>
Metered	90%	0.1%	0.342 to 0.343
Estimated	70%	12.9%	0.246 to 0.319

\* Both precision and confidence interval are given according to the corresponding confidence level. In cases where an accuracy level of 90% confidence and 10% precision (i.e., 90/10) was not achieved the reported precision values and confidence intervals are based on a 70% confidence level.

**Table C-10: Uncertainty Analysis Results for CCSE Annual Energy Impact**

<b>Technology / Basis</b>	<b>Confidence Level</b>	<b>Precision*</b>	<b>Confidence Interval*</b>
<b>FC</b>	<b>90%</b>	<b>5.5%</b>	<b>0.400 to 0.447</b>
Metered	90%	0.1%	0.371 to 0.372
Estimated	70%	12.1%	0.572 to 0.729
<b>GT</b>	<b>90%</b>	<b>0.1%</b>	<b>0.951 to 0.952</b>
Metered	90%	0.1%	0.951 to 0.952
Estimated	N/A	N/A	N/A
<b>IC Engine</b>	<b>90%</b>	<b>0.7%</b>	<b>0.135 to 0.137</b>
Metered	90%	0.1%	0.136 to 0.136
Estimated	70%	86.1%	0.033 to 0.442
<b>MT</b>	<b>90%</b>	<b>5.0%</b>	<b>0.172 to 0.190</b>
Metered	90%	0.1%	0.175 to 0.175
Estimated	70%	52.2%	0.159 to 0.507

\* Both precision and confidence interval are given according to the corresponding confidence level. In cases where an accuracy level of 90% confidence and 10% precision (i.e., 90/10) was not achieved the reported precision values and confidence intervals are based on a 70% confidence level.

**Table C-11: Uncertainty Analysis Results for Peak Demand Impact**

<b>Technology / Basis</b>	<b>Confidence Level</b>	<b>Precision*</b>	<b>Confidence Interval*</b>
<b>FC</b>	<b>90%</b>	<b>8.61%</b>	<b>0.594 to 0.706</b>
Metered	90%	0.09%	0.721 to 0.723
Estimated	70%	16.4%	0.456 to 0.635
<b>GT</b>	<b>90%</b>	<b>4.02%</b>	<b>0.760 to 0.824</b>
Metered	90%	0.21%	0.824 to 0.828
Estimated	70%	51.2%	0.216 to 0.670
<b>IC Engine</b>	<b>90%</b>	<b>8.81%</b>	<b>0.290 to 0.346</b>
Metered	90%	0.08%	0.282 to 0.282
Estimated	70%	12.8%	0.332 to 0.429
<b>MT</b>	<b>90%</b>	<b>8.70%</b>	<b>0.287 to 0.342</b>
Metered	90%	0.10%	0.309 to 0.310
Estimated	70%	23.1%	0.249 to 0.398

\* Both precision and confidence interval are given according to the corresponding confidence level. In cases where an accuracy level of 90% confidence and 10% precision (i.e., 90/10) was not achieved the reported precision values and confidence intervals are based on a 70% confidence level.

**Table C-12: Uncertainty Analysis Results for Peak Demand Impact Results by Technology, Fuel, and Basis for PG&E**

<b>Technology &amp; Fuel/ Basis</b>	<b>Confidence Level</b>	<b>Precision*</b>	<b>Confidence Interval*</b>
<b>FC-N</b>	<b>70%</b>	<b>6.8%</b>	<b>0.698 to 0.800</b>
Metered	90%	0.1%	0.797 to 0.799
Estimated	70%	26.5%	0.467 to 0.804
<b>FC-R</b>	<b>70%</b>	<b>22.2%</b>	<b>0.525 to 0.825</b>
Metered	90%	0.4%	0.836 to 0.843
Estimated	70%	100%	0.00 to 0.800
<b>GT-N</b>	<b>70%</b>	<b>51.2%</b>	<b>0.142 to 0.439</b>
Metered	N/A	N/A	N/A
Estimated	70%	51.2%	0.216 to 0.670
<b>IC Engine-N</b>	<b>70%</b>	<b>10.5%</b>	<b>0.282 to 0.347</b>
Metered	90%	0.1%	0.265 to 0.265
Estimated	70%	20.3%	0.304 to 0.458
<b>IC Engine-R</b>	<b>70%</b>	<b>22.2%</b>	<b>0.420 to 0.660</b>
Metered	90%	0.2%	0.517 to 0.519
Estimated	70%	51.6%	0.278 to 0.869
<b>MT-N</b>	<b>70%</b>	<b>8.6%</b>	<b>0.435 to 0.517</b>
Metered	90%	0.2%	0.533 to 0.535
Estimated	70%	33.2%	0.243 to 0.484
<b>MT-R</b>	<b>70%</b>	<b>27.9%</b>	<b>0.166 to 0.295</b>
Metered	90%	0.3%	0.213 to 0.214
Estimated	70%	84.5%	0.043 to 0.510

\* Both precision and confidence interval are given according to the corresponding confidence level. In cases where an accuracy level of 90% confidence and 10% precision (i.e., 90/10) was not achieved the reported precision values and confidence intervals are based on a 70% confidence level.



**Table C-13: Uncertainty Analysis Results for Peak Demand Impact Results by Technology, Fuel, and Basis for SCE**

<b>Technology &amp; Fuel/ Basis</b>	<b>Confidence Level</b>	<b>Precision*</b>	<b>Confidence Interval*</b>
<b>FC-N</b>	<b>70%</b>	<b>7.3%</b>	<b>0.792 to 0.917</b>
Metered	90%	0.2%	0.915 to 0.919
Estimated	70%	22.5%	0.581 to 0.919
<b>FC-R</b>	<b>70%</b>	<b>51.5%</b>	<b>0.139 to 0.433</b>
Metered	90%	0.0%	0.000 to 0.000
Estimated	70%	51.5%	0.192 to 0.600
<b>IC Engine-N</b>	<b>70%</b>	<b>16.8%</b>	<b>0.220 to 0.309</b>
Metered	90%	0.2%	0.221 to 0.222
Estimated	70%	34.1%	0.218 to 0.443
<b>IC Engine-R</b>	<b>70%</b>	<b>35.5%</b>	<b>0.103 to 0.215</b>
Metered	90%	0.4%	0.001 to 0.001
Estimated	70%	35.7%	0.450 to 0.950
<b>MT-N</b>	<b>70%</b>	<b>15.5%</b>	<b>0.210 to 0.287</b>
Metered	90%	0.3%	0.235 to 0.237
Estimated	70%	49.6%	0.142 to 0.422
<b>MT-R</b>	<b>70%</b>	<b>11.6%</b>	<b>0.130 to 0.164</b>
Metered	90%	0.5%	0.136 to 0.137
Estimated	70%	100.0%	0.000 to 0.700

\* Both precision and confidence interval are given according to the corresponding confidence level. In cases where an accuracy level of 90% confidence and 10% precision (i.e., 90/10) was not achieved the reported precision values and confidence intervals are based on a 70% confidence level.

**Table C-14: Uncertainty Analysis Results for Peak Demand Impact Results by Technology, Fuel, and Basis for SCG**

<b>Technology &amp; Fuel/ Basis</b>	<b>Confidence Level</b>	<b>Precision*</b>	<b>Confidence Interval*</b>
<b>FC-N</b>	<b>70%</b>	<b>17.7%</b>	<b>0.580 to 0.828</b>
Metered	90%	0.3%	0.771 to 0.775
Estimated	70%	99.1%	0.004 to 0.995
<b>FC-R</b>	<b>70%</b>	<b>54.3%</b>	<b>0.178 to 0.600</b>
Metered	90%	0.3%	0.771 to 0.775
Estimated	70%	54.3%	0.179 to 0.600
<b>GT-N</b>	<b>90%</b>	<b>0.3%</b>	<b>0.817 to 0.822</b>
Metered	90%	0.3%	0.817 to 0.822
Estimated	70%	54.3%	0.178 to 0.600
<b>IC Engine-N</b>	<b>70%</b>	<b>8.8%</b>	<b>0.323 to 0.385</b>
Metered	90%	0.1%	0.360 to 0.361
Estimated	70%	25.0%	0.256 to 0.427
<b>IC Engine-R</b>	<b>70%</b>	<b>29.3%</b>	<b>0.514 to 0.940</b>
Metered	90%	0.4%	1.000 to 1.009
Estimated	70%	64.4%	0.195 to 0.900
<b>MT-N</b>	<b>70%</b>	<b>9.0%</b>	<b>0.215 to 0.257</b>
Metered	90%	0.2%	0.228 to 0.229
Estimated	70%	49.7%	0.140 to 0.418

\* Both precision and confidence interval are given according to the corresponding confidence level. In cases where an accuracy level of 90% confidence and 10% precision (i.e., 90/10) was not achieved the reported precision values and confidence intervals are based on a 70% confidence level.

**Table C-15: Uncertainty Analysis Results for Peak Demand Impact Results by Technology, Fuel, and Basis for CCSE**

<b>Technology &amp; Fuel/ Basis</b>	<b>Confidence Level</b>	<b>Precision*</b>	<b>Confidence Interval*</b>
<b>FC-N</b>	<b>70%</b>	<b>15.8%</b>	<b>0.352 to 0.484</b>
Metered	90%	0.3%	0.336 to 0.337
Estimated	70%	38.5%	0.400 to 0.900
<b>GT-N</b>	<b>90%</b>	<b>0.3%</b>	<b>0.957 to 0.964</b>
Metered	90%	0.3%	0.957 to 0.964
Estimated	N/A	N/A	N/A
<b>IC Engine-N</b>	<b>90%</b>	<b>0.3%</b>	<b>0.070 to 0.070</b>
Metered	90%	0.3%	0.070 to 0.070
Estimated	N/A	N/A	N/A
<b>IC Engine-R</b>	<b>90%</b>	<b>0.4%</b>	<b>0.935 to 0.943</b>
Metered	90%	0.3%	0.070 to 0.070
Estimated	N/A	N/A	N/A
<b>MT-N</b>	<b>90%</b>	<b>9.8%</b>	<b>0.222 to 0.270</b>
Metered	90%	0.3%	0.234 to 0.235
Estimated	70%	100%	0.000 to 0.700
<b>MT-R</b>	<b>90%</b>	<b>0.4%</b>	<b>0.049 to 0.050</b>
Metered	90%	0.4%	0.049 to 0.050
Estimated	N/A	N/A	N/A

\* Both precision and confidence interval are given according to the corresponding confidence level. In cases where an accuracy level of 90% confidence and 10% precision (i.e., 90/10) was not achieved the reported precision values and confidence intervals are based on a 70% confidence level.

**Table C-16: Uncertainty Analysis Results for Annual PUC 216.6(b)**

<b>Technology / Basis</b>	<b>Confidence Level</b>	<b>Precision*</b>	<b>Confidence Interval*</b>
<b>FC</b>	<b>90%</b>	<b>0.81%</b>	<b>0.483 to 0.491</b>
Metered	90%	1.80%	0.518 to 0.537
Estimated	90%	0.82%	0.482 to 0.490
<b>GT</b>	<b>90%</b>	<b>2.95%</b>	<b>0.427 to 0.453</b>
Metered	90%	1.52%	0.420 to 0.433
Estimated	90%	6.34%	0.429 to 0.487
<b>IC Engine</b>	<b>90%</b>	<b>1.50%</b>	<b>0.459 to 0.473</b>
Metered	90%	0.58%	0.463 to 0.469
Estimated	90%	1.69%	0.459 to 0.474
<b>MT</b>	<b>90%</b>	<b>2.86%</b>	<b>0.316 to 0.335</b>
Metered	90%	4.17%	0.302 to 0.328
Estimated	90%	3.81%	0.319 to 0.344

\* Both precision and confidence interval are given according to the corresponding confidence level. In cases where an accuracy level of 90% confidence and 10% precision (i.e., 90/10) was not achieved the reported precision values and confidence intervals are based on a 70% confidence level.

# ***Appendix D***

## **Cumulative System Cost and Incentive Trends**

---

Table D-1 is a summary listing of cumulative system costs and incentive trends by technology. The table includes data from PY01 through PY10 but excludes any PV projects that were originally provided incentives under the SGIP. PY11 is not shown in the table because data were available for only one project.

**Table D-1: Cumulative System Cost and Incentive Trends**

Technology		Program Year (Millions of Dollars)										
		PY01	PY02	PY03	PY04	PY05	PY06	PY07	PY08	PY09	PY10	CUMULATIVE
Fuel Cells	Eligible Costs	\$4.57	\$5.33	\$8.90	\$20.21	\$25.87	\$41.76	\$9.03	\$6.30	\$48.80	\$194.01	\$364.78
	Incentive	\$0.64	\$1.88	\$4.13	\$6.64	\$9.09	\$21.72	\$3.25	\$2.91	\$17.33	\$77.54	\$145.12
	Leverage Ratio	<b>6.20</b>	<b>1.84</b>	<b>1.16</b>	<b>2.04</b>	<b>1.85</b>	<b>0.92</b>	<b>1.77</b>	<b>1.16</b>	<b>1.82</b>	<b>1.50</b>	<b>1.51</b>
IC Engines	Eligible Costs	\$39.01	\$101.43	\$99.43	\$73.27	\$61.71	\$33.22	\$35.70	N/A	N/A	N/A	\$443.78
	Incentive	\$11.48	\$25.85	\$26.33	\$20.08	\$13.97	\$7.76	\$6.96	N/A	N/A	N/A	\$112.42
	Leverage Ratio	<b>2.40</b>	<b>2.92</b>	<b>2.78</b>	<b>2.65</b>	<b>3.42</b>	<b>3.28</b>	<b>4.13</b>	N/A	N/A	N/A	<b>2.95</b>
Microturbines	Eligible Costs	\$10.34	\$10.52	\$21.29	\$20.84	\$13.38	\$15.71	\$5.55	N/A	N/A	N/A	\$97.62
	Incentive	\$2.81	\$2.91	\$5.85	\$6.04	\$3.28	\$3.66	\$1.03	N/A	N/A	N/A	\$25.58
	Leverage Ratio	<b>2.67</b>	<b>2.61</b>	<b>2.64</b>	<b>2.45</b>	<b>3.08</b>	<b>3.29</b>	<b>4.39</b>	N/A	N/A	N/A	<b>2.82</b>
Gas Turbines	Eligible Costs	N/A	\$4.67	\$5.73	\$8.56	\$15.32	\$33.00	N/A	N/A	N/A	N/A	\$67.27
	Incentive	N/A	\$1.01	\$1.22	\$1.19	\$1.21	\$2.01	N/A	N/A	N/A	N/A	\$6.65
	Leverage Ratio	N/A	<b>3.61</b>	<b>3.69</b>	<b>6.18</b>	<b>11.64</b>	<b>15.43</b>	N/A	N/A	N/A	N/A	<b>9.12</b>
Wind	Eligible Costs	N/A	N/A	\$6.57	N/A	N/A	N/A	\$6.89	\$0.36	\$5.39	\$5.56	\$24.78
	Incentive	N/A	N/A	\$3.22	N/A	N/A	N/A	\$1.99	\$0.27	\$2.52	\$0.00	\$8.01
	Leverage Ratio	N/A	N/A	<b>1.04</b>	N/A	N/A	N/A	<b>2.46</b>	<b>0.34</b>	<b>1.14</b>	N/A	<b>2.09</b>
Overall	Eligible Costs	\$53.92	\$121.95	\$141.91	\$122.87	\$116.28	\$123.69	\$57.16	\$6.66	\$54.19	\$199.57	\$998.23
	Incentive	\$14.93	\$31.65	\$40.74	\$33.94	\$27.55	\$35.14	\$13.23	\$3.18	\$19.85	\$77.54	\$297.77
	Leverage Ratio	<b>2.61</b>	<b>2.85</b>	<b>2.48</b>	<b>2.62</b>	<b>3.22</b>	<b>2.52</b>	<b>3.32</b>	<b>1.09</b>	<b>1.73</b>	<b>1.57</b>	<b>2.35</b>

**Table D-2: Renewable and Non-Renewable Cumulative System Cost and Incentive Trends**

Technology & Fuel Type			Program Year (Millions of Dollars)										
			PY01	PY02	PY03	PY04	PY05	PY06	PY07	PY08	PY09	PY10	CUMULATIVE
Fuel Cells	Non-Renewable	Eligible Costs	\$4.57	\$5.33	N/A	\$20.21	\$25.87	\$17.12	\$9.03	\$0.36	\$23.55	\$22.49	\$128.53
		Incentive	\$0.64	\$1.88	N/A	\$6.64	\$9.09	\$4.14	\$3.25	\$0.09	\$6.76	\$5.31	\$37.80
		Leverage Ratio	<b>6.20</b>	<b>1.84</b>	<b>N/A</b>	<b>2.04</b>	<b>1.85</b>	<b>3.13</b>	<b>1.77</b>	<b>2.92</b>	<b>2.48</b>	<b>3.23</b>	<b>2.40</b>
	Renewable (Biogas)	Eligible Costs	N/A	N/A	\$8.90	N/A	N/A	\$24.65	N/A	\$5.95	\$25.25	\$171.52	\$236.27
		Incentive	N/A	N/A	\$4.13	N/A	N/A	\$17.57	N/A	\$2.82	\$10.57	\$72.22	\$107.31
		Leverage Ratio	<b>N/A</b>	<b>N/A</b>	<b>1.16</b>	<b>N/A</b>	<b>N/A</b>	<b>0.40</b>	<b>N/A</b>	<b>1.11</b>	<b>1.39</b>	<b>1.37</b>	<b>1.20</b>
IC Engines	Non-Renewable	Eligible Costs	\$36.47	\$101.43	\$96.83	\$70.26	\$48.52	\$22.66	\$19.48	N/A	N/A	N/A	\$395.65
		Incentive	\$10.59	\$25.85	\$25.37	\$19.05	\$8.97	\$4.38	\$3.64	N/A	N/A	N/A	\$97.85
		Leverage Ratio	<b>2.44</b>	<b>2.92</b>	<b>2.82</b>	<b>2.69</b>	<b>4.41</b>	<b>4.17</b>	<b>4.36</b>	<b>N/A</b>	<b>N/A</b>	<b>N/A</b>	<b>3.04</b>
	Renewable (Biogas)	Eligible Costs	\$2.54	N/A	\$2.60	\$3.02	\$13.20	\$10.57	\$16.22	N/A	N/A	N/A	\$48.15
		Incentive	\$0.89	N/A	\$0.96	\$1.03	\$5.00	\$3.38	\$3.32	N/A	N/A	N/A	\$14.58
		Leverage Ratio	<b>1.86</b>	<b>N/A</b>	<b>1.71</b>	<b>1.93</b>	<b>1.64</b>	<b>2.13</b>	<b>3.89</b>	<b>N/A</b>	<b>N/A</b>	<b>N/A</b>	<b>2.30</b>
Micro turbines	Non-Renewable	Eligible Costs	\$8.30	\$8.54	\$16.61	\$18.30	\$9.92	\$14.72	\$5.55	N/A	N/A	N/A	\$81.94
		Incentive	\$2.20	\$2.12	\$4.30	\$5.25	\$2.19	\$3.25	\$1.03	N/A	N/A	N/A	\$20.34
		Leverage Ratio	<b>2.77</b>	<b>3.03</b>	<b>2.87</b>	<b>2.49</b>	<b>3.53</b>	<b>3.52</b>	<b>4.39</b>	<b>N/A</b>	<b>N/A</b>	<b>N/A</b>	<b>3.03</b>
	Renewable (Biogas)	Eligible Costs	\$2.04	\$1.98	\$4.68	\$2.53	\$3.46	\$0.99	N/A	N/A	N/A	N/A	\$15.68
		Incentive	\$0.61	\$0.79	\$1.55	\$0.79	\$1.09	\$0.41	N/A	N/A	N/A	N/A	\$5.24
		Leverage Ratio	<b>2.33</b>	<b>1.50</b>	<b>2.02</b>	<b>2.21</b>	<b>2.17</b>	<b>1.44</b>	<b>N/A</b>	<b>N/A</b>	<b>N/A</b>	<b>N/A</b>	<b>1.99</b>

**Table D-3: Renewable and Non-Renewable Cumulative System Cost and Incentive Trends—Continued**

Technology & Fuel Type			Program Year (Millions of Dollars)										
			PY01	PY02	PY03	PY04	PY05	PY06	PY07	PY08	PY09	PY10	CUMULATIVE
Gas Turbines	Non-Renewable	Eligible Costs	N/A	\$4.67	\$5.73	\$8.56	\$15.32	\$33.00	N/A	N/A	N/A	N/A	\$67.28
		Incentive	N/A	\$1.01	\$1.22	\$1.19	\$1.21	\$2.01	N/A	N/A	N/A	N/A	\$6.64
		Leverage Ratio	N/A	<b>3.61</b>	<b>3.69</b>	<b>6.18</b>	<b>11.64</b>	<b>15.43</b>	N/A	N/A	N/A	N/A	<b>9.13</b>
Wind	Renewable (Wind)	Eligible Costs	N/A	N/A	\$6.57	N/A	N/A	N/A	\$6.89	\$0.36	\$5.39	\$5.56	\$24.77
		Incentive	N/A	N/A	\$3.22	N/A	N/A	N/A	\$1.99	\$0.27	\$2.52	\$0.00	\$8.00
		Leverage Ratio	N/A	N/A	<b>1.04</b>	N/A	N/A	N/A	<b>2.46</b>	<b>0.34</b>	<b>1.14</b>	N/A	<b>2.10</b>
Overall	Non-Renewable	Eligible Costs	\$49.34	\$119.97	\$119.17	\$117.33	\$99.62	\$87.49	\$34.05	\$0.36	\$23.55	\$22.49	\$673.37
		Incentive	\$13.43	\$30.86	\$30.89	\$32.13	\$21.46	\$13.79	\$7.92	\$0.09	\$6.76	\$5.31	\$162.64
		Leverage Ratio	<b>2.67</b>	<b>2.89</b>	<b>2.86</b>	<b>2.65</b>	<b>3.64</b>	<b>5.35</b>	<b>3.30</b>	<b>2.92</b>	<b>2.48</b>	<b>3.23</b>	<b>3.14</b>
	Renewable (Biogas)	Eligible Costs	\$4.58	\$1.98	\$16.18	\$5.55	\$16.66	\$36.20	\$16.22	\$5.95	\$25.25	\$171.52	\$300.09
		Incentive	\$1.50	\$0.79	\$6.64	\$1.82	\$6.09	\$21.36	\$3.32	\$2.82	\$10.57	\$72.22	\$127.13
		Leverage Ratio	<b>2.05</b>	<b>1.50</b>	<b>1.44</b>	<b>2.05</b>	<b>1.73</b>	<b>0.69</b>	<b>3.89</b>	<b>1.11</b>	<b>1.39</b>	<b>1.37</b>	<b>1.36</b>
	Renewable (Wind)	Eligible Costs	N/A	N/A	\$6.57	N/A	N/A	N/A	\$6.89	\$0.36	\$5.39	\$5.56	\$24.77
		Incentive	N/A	N/A	\$3.22	N/A	N/A	N/A	\$1.99	\$0.27	\$2.52	\$0.00	\$8.00
		Leverage Ratio	N/A	N/A	<b>1.04</b>	N/A	N/A	N/A	<b>2.46</b>	<b>0.34</b>	<b>1.14</b>	N/A	<b>2.10</b>