

Volume III

PIPELINE SAFETY AND ENHANCEMENT PLAN (PSEP) 2018 REASONABLENESS REVIEW – A.18-11-010 WORKPAPERS TABLE OF CONTENTS

Workpaper Page No.	Workpaper Chapter Title
WP-Intro-1 - 16	Introduction to Workpapers Supporting the Testimony of Rick Phillips: Chapter II, Chapter III, and Hugo Mejia: Chapter IV
WP-SCS-1 - 19	Appendix A - Standard Construction Summary for Replacement, Hydrotest and PSEP Valve Projects
WP-G-1 - 13	Appendix B - Glossary
WP-III-A1 - A1037	Pipeline Pressure Test/Replacement Projects
WP-IV-A1 - A914	Valve Enhancement Projects
WP-VII-A1 - A6	Company Overheads
WP-IX-A1 - A8	Revenue Requirements

WP-IV-A1 - A914
Valve Enhancement Projects

VALVE ENHANCEMENT PROJECTS

Table 2 – Valve Projects for 2018 Reasonableness Review

Valve Workpaper Title	Project Scope	Utility	Workpaper Page
Alhambra Station Valve Enhancement Project	2 Valves/1 site	SoCalGas	WP-IV-A1 - A20
Aviation and Boardwalk Valve Enhancement Project	2 Valves/1 site	SoCalGas	WP-IV-A21 - A40
Banning 5000 Valve Enhancement Project Bundle	2 Valves/2 sites	SoCalGas	WP-IV-A41 - A62
El Segundo Valve Enhancement Project	2 Valves/1 site	SoCalGas	WP-IV-A63 - A83
Haynes Station Valve Enhancement Project	3 Valves/1 site	SoCalGas	WP-IV-A84 - A101
Honor Ranch Valve Enhancement Project Bundle	4 Valves/2 sites	SoCalGas	WP-IV-A102- A126
Indio Valve Enhancement Project Bundle	4 Valves/2 sites	SoCalGas	WP-IV-A127 - 152
Lampson Valve Enhancement Project Bundle	4 Valves/2 sites	SoCalGas	WP-IV-A153 - A179
Line 1005 Santa Barbara Valve Enhancement Project	1 Valve/1 site	SoCalGas	WP-IV-A180 - A195
Line 1014 Brea Valve Enhancement Project Bundle	4 Valves/2 sites	SoCalGas	WP-IV-A196 - A220
Line 1018 Dana Point Valve Enhancement Project	1 Valve/1 site	SoCalGas	WP-IV-A221 - A238
Line 1020 Valve Enhancement Project	1 Valve/1 site	SoCalGas	WP-IV-A239 - A255
Line 1600 Valve Enhancement Project Bundle	16 Valves/17 sites	SDG&E	WP-IV-A256 - A289
Line 2000 Beaumont Riverside Valve Enhancement Project Bundle	3 Valves/3 sites	SoCalGas	WP-IV-A290 - A312
Line 2001 Riverside Valve Enhancement Project Bundle	3 Valves/2 sites	SoCalGas	WP-IV-A313 - A336
Line 2001 West Section 10 & 11 Valve Enhancement Project	1 Valve/1 site	SoCalGas	WP-IV-A337 - A354
Line 2003 East Valve Enhancement Project Bundle	5 Valves/3 sites	SoCalGas	WP-IV-A355 - A382
Line 2003 West Valve Enhancement Project Bundle	2 Valves/3 sites	SoCalGas	WP-IV-A383 - A408
Line 225 Valve Enhancement Project Bundle	2 Valves/3 sites	SoCalGas	WP-IV-A409 - A433
Line 235-335 East Valve Enhancement Project Bundle	7 Valves/6 sites	SoCalGas	WP-IV-A434 - A471
Line 3010 Valve Enhancement Project Bundle	9 Valves/9 sites	SDG&E	WP-IV-A472 - A498
Line 3600 Valve Enhancement Project Bundle	12 Valves/6 sites	SDG&E	WP-IV-A499 - A534
Line 4000 Benson and 7th Valve Enhancement Project	1 Valve/1 site	SoCalGas	WP-IV-A535 - A551
Line 4000 MP 45.36 Valve Enhancement Project	1 Valve/1 site	SoCalGas	WP-IV-A552 - A568
Line 4000 MP 53.00 Valve Enhancement Project	1 Valve/1 site	SoCalGas	WP-IV-A569 - A585
Line 4000 MP 80.08 Valve Enhancement Project	1 Valve/1 site	SoCalGas	WP-IV-A586 - A604
Line 4002 Fontana Valve Enhancement Project	1 Valve/1 site	SoCalGas	WP-IV-A605 - A621
Line 404 Ventura Valve Enhancement Project Bundle	4 Valves/3 sites	SoCalGas	WP-IV-A622 - A646
Line 404-406 Ventura Valve Enhancement Bundle	3 Valves/2 sites	SoCalGas	WP-IV-A647 - A669
Line 406 Ventura Valve Enhancement Project Bundle	5 Valves/4 sites	SoCalGas	WP-IV-A670 - A699

Table 2 – Valve Projects for 2018 Reasonableness Review (Continued)

Valve Workpaper Title	Project Scope	Utility	Workpaper Page
Line 49-28 RCV Upgrade Valve Enhancement Project	1 Valve/1 site	SDG&E	WP-IV-A700 - A715
Line 6916 Valve Enhancement Project Bundle	3 Valves/3 sites	SoCalGas	WP-IV-A716 - A739
Line 7000 Valve Enhancement Project Bundle	2 Valves/2 sites	SoCalGas	WP-IV-A740 - A760
New Desert Valve Enhancement Project Bundle	7 Valves/2 sites	SoCalGas	WP-IV-A761 - A786
Newhall Valve Enhancement Project Bundle	7 Valves/3 sites	SoCalGas	WP-IV-A787 - A815
Orange Valve Enhancement Project Bundle	3 Valves/3 sites	SoCalGas	WP-IV-A816 - A847
Questar Taps Valve Enhancement Project	6 Valves/1 site	SoCalGas	WP-IV-A848 - A865
Rainbow Valve Enhancement Project Bundle	10 Valves/4 sites	SoCalGas	WP-IV-A866 - A896
Sepulveda Station Valve Enhancement Project	1 Valve/1 site	SoCalGas	WP-IV-A897 - A914

Pipeline Safety Enhancement Plan Final Report
Alhambra Station Valve Enhancement Project

I. ALHAMBRA STATION VALVE ENHANCEMENT PROJECT

A. Background and Summary

This report describes the activities associated with the Alhambra Station Valve Enhancement Project that consists of enhancements made to two new mainline valves (MLVs) in the City of Alhambra in Los Angeles County. Through this project, SoCalGas and SDG&E enhanced the capabilities of two new MLVs to enable rapid transmission system isolation to a portion of Line 3000. SoCalGas and SDG&E installed two new valves, two new actuators, a new blowdown assembly, and a new flow meter in a new vault. The total loaded project cost is \$3,587,677.

The Alhambra Station Valve Enhancement Project site is an existing SoCalGas facility in the City of Alhambra. All work was done within the station where there was sufficient space for a laydown area.

Pipeline Safety Enhancement Plan Final Report
Alhambra Station Valve Enhancement Project

Table 1: General Project Information

Alhambra Station Valve Enhancement Project			
Location	City of Alhambra		
Days on Site	71 days		
Construction Start	04/20/2015		
Construction Finish	08/19/2015		
Commissioning Date	11/04/2015		
Valve Upgrades			
Valve Number	3000-285.97-31		
Valve Type	New – Ball		
Actuator	New		
Actuator Above-Grade/Below-Grade	Above		
ASV	Yes		
RCV	Yes		
Valve Number	3000-285.97-50		
Valve Type	New – Ball		
Actuator	New		
Actuator Above-Grade/Below-Grade	Above		
ASV	Yes		
RCV	Yes		
Site Upgrades			
Vault	New		
Power	Existing – Utility		
Communication	Existing – Utility		
SCADA Panel	New		
Equipment Shelter	None		
Wall	Existing		
Project Costs (\$)	Capital	O&M	Total
Loaded Project Costs	3,587,677	-	3,587,677
Disallowed Costs	-	-	-

Pipeline Safety Enhancement Plan Final Report
Alhambra Station Valve Enhancement Project

B. Maps and Images

Figure 1: Satellite Image of Alhambra Station Valve Enhancement Project

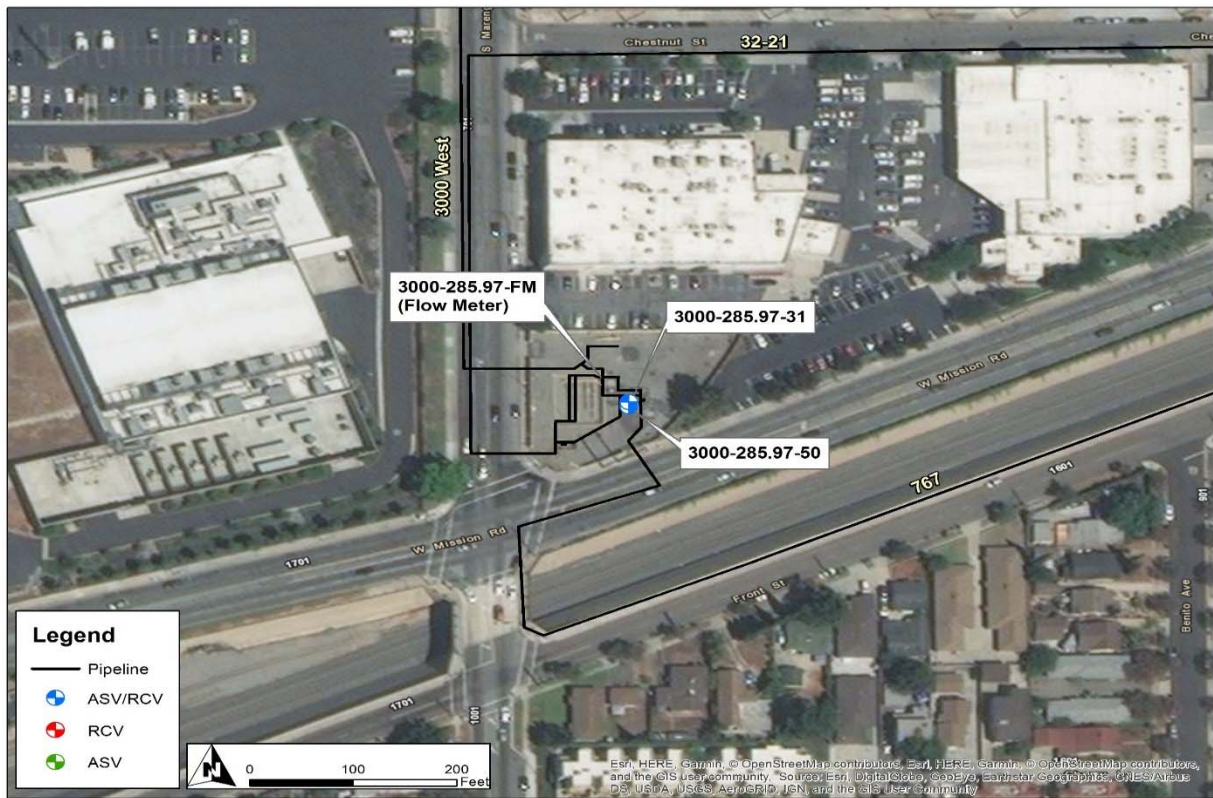

Pipeline Safety Enhancement Plan Final Report
Alhambra Station Valve Enhancement Project

II. ENGINEERING, DESIGN, AND PLANNING

A. Project Scope

SoCalGas and SDG&E presented a conceptual project scope in workpapers supporting the Valve Enhancement Plan¹ in the 2011 filing. This conceptual scope identified MLV 3000-285.91-59 for automation to provide remote isolation to a portion of Line 3000. Prior to initiating execution of the Project, SoCalGas and SDG&E reviewed available information and performed a detailed system flow analysis to validate the scope of the Project. The Project Team determined that the valve listed in the filing is normally closed and is not a candidate for automation. The final project scope is summarized in Table 2 below.

1. 2011 PSEP Filing: SoCalGas and SDG&E identified MLV 3000-285.91-59 for automation to achieve the objective of rapid system isolation.

¹ See Workpapers supporting Amended Pipeline Safety Enhancement Plan (PSEP) of SoCalGas and SDG&E, submitted on December 2, 2011, at WP-IX-2-14 through WP-IX-2-25 (A.11-11-002 Exh. # SCG-32).

Pipeline Safety Enhancement Plan Final Report
Alhambra Station Valve Enhancement Project

2. Updated Scope: Upon project initiation, SoCalGas and SDG&E reviewed the conceptual project scope and determined that this isolation point would not achieve the transmission isolation objectives set forth in the Valve Enhancement Plan. SoCalGas and SDG&E determined it was necessary to automate valves 3000-285.97-31 and 3000-285.97-50. SoCalGas and SDG&E also determined that the installation of a flowmeter on Line 3000 was necessary to determine the direction of flow in the case of a linebreak. Together, the automation of these valves and the installation of the flow meter enables rapid isolation, achieving Valve Enhancement Plan objectives.
3. Engineering, Design, and Constructability: The preexisting valves were plug valves and were positioned on their side and required modifications so that the valve stem is vertical. The Project Team would have to make additional retrofits to the valve to modify it and place it back in service. Due to the cost of these retrofits and the age of the valves, The Project Team decided to replace the existing plug valves with two new ball valves.
4. Final Project Scope: The final project scope consists of the automation of two valves that included the installation of two new valves, two new actuators, the relocation and replacement of a preexisting blowdown assembly, the installation of the necessary automation equipment, and the installation of a flowmeter in a new vault at the project site.

Pipeline Safety Enhancement Plan Final Report
Alhambra Station Valve Enhancement Project

Table 2: Final Project Scope

Final Project Scope					
Line	Mile	Valve #	Valve Size (<i>confidential</i>)	Installation Type	Function
3000	285.97	31		NV/AG	ASV/RCV
3000	285.97	50		NV/AG	ASV/RCV
3000	285.97	FM		FM	FLOWMETER

B. Site Evaluation and Planning

SoCalGas and SDG&E initiated the planning process for the Alhambra Station Valve Enhancement Project by performing a pre-design site walk to determine the existing conditions and assess any potential impacts on the design. Key factors that influenced the engineering and design of this project are as follows:

1. Site Description: The site is an existing SoCalGas owned facility, located in a high-density area that is a mix of industrial and commercial businesses.
2. Land Issues: During the pre-design site walk, the Project Team noted that the existing facility can accommodate the new equipment.
3. DOT Class: This project is in a Class 3 location.
4. Power Source: The site has existing utility power.
5. Communication Technology: The site has existing utility communications.

Pipeline Safety Enhancement Plan Final Report
Alhambra Station Valve Enhancement Project

C. Engineering, Design, and Planning Factors

SoCalGas and SDG&E reviewed drawings and records, contacted internal planning groups, communicated with external stakeholders, and completed a pre-design site walk. Key factors that influenced the engineering and design of the Project are as follows:

1. Engineering Assessment:

- a. During the site evaluation, the Project Team confirmed the preexisting technology and verified that the station could accommodate the new equipment. The existing plug valves were not piggable and were positioned on their side, the Project Team determined that these valves required modifications that would have required additional retrofits before they were placed back into service.
- b. The Project Team determined that the installation of the new MLV 3000-285.97-31 would require a relocation of the preexisting blowdown.

2. Valve Details:

- a. MLV 3000-285.97-31: The preexisting valve was a manually operated Class 400 plug valve that the Project Team replaced.
- b. MLV 3000-285.97-50: The preexisting valve was a manually actuated Class 300 plug valve that the Project Team replaced.

Pipeline Safety Enhancement Plan Final Report
Alhambra Station Valve Enhancement Project

3. Actuator Details:

- a. MLV 3000-285.97-31: There was no preexisting actuator, the Project Team installed a new actuator.
- b. MLV 3000-285.97-50: The preexisting actuator was incompatible with PSEP linebreak technology, the Project Team installed a new actuator.

4. Customer Impact:

- a. The installation of the new valve assembly required a blowdown of Line 3000, resulting in the shut-in of Supply Line 32-21; this line serves many core and noncore customers, including a Power Plant. The Project Team utilized a temporary regulator station during the tie-in to maintain service to customers.
- b. Regulator station ID12-N also was shut-in during the blowdown. The Project Team avoided the need for CNG or LNG by performing the blowdown and tie-in during summer conditions.

5. Community Impact: The Project Team did not anticipate any notable impacts to the community from this project.

6. Substructures: The Project Team did not identify any existing substructures that affected the design and engineering at this site.

7. Environmental: The Project Team did not identify any notable environmental concerns at the site. An environmental monitor performed spot checks during construction.

Pipeline Safety Enhancement Plan Final Report
Alhambra Station Valve Enhancement Project

8. Permit Restrictions: There were no special permits or permit restrictions for this project site.
9. Land Use: The Project Team performed all work within the existing SoCalGas facility.
10. Traffic Control: The Project Team did not identify any traffic control needs at the site.

Pipeline Safety Enhancement Plan Final Report
Alhambra Station Valve Enhancement Project

Figure 2: Alhambra Station Valve Enhancement Project Schematic

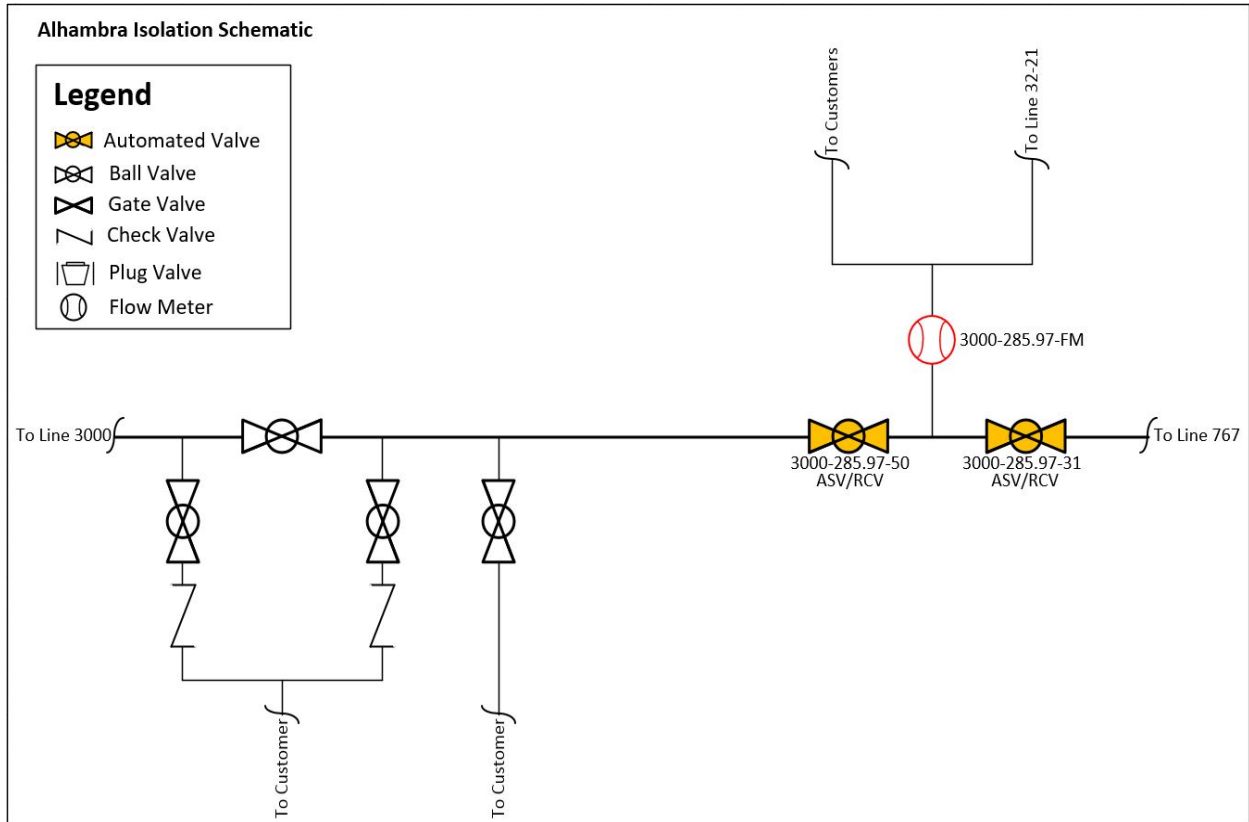

Pipeline Safety Enhancement Plan Final Report
Alhambra Station Valve Enhancement Project

D. Scope Changes

SoCalGas and SDG&E did not make any notable scope changes during detailed design.

Pipeline Safety Enhancement Plan Final Report
Alhambra Station Valve Enhancement Project

III. CONSTRUCTION

A. Construction Contractor Selection

The Project Team prepared an initial cost estimate based on the preliminary design. Following completion of the engineering, design, and planning activities described above, the Project Team directed the Performance Partner (Mechanical Construction Contractor) and Alliance Partner (Electrical Contractor) area to prepare cost estimates based on a more detailed engineering design package. As indicated above, there were no notable changes in scope between the time when the Project Team prepared the preliminary cost estimate and when the Performance Partner and Alliance Partner prepared and submitted their estimates.

1. SoCalGas and SDG&E's Preliminary Mechanical Construction Contractor Estimate (*confidential*): SoCalGas and SDG&E's preliminary cost estimate for construction was [REDACTED].
2. Mechanical Construction Contractor's Target Price Estimate (*confidential*): The Mechanical Construction Contractor's cost estimate was [REDACTED], which was [REDACTED] than SoCalGas and SDG&E's preliminary cost estimate for construction.
3. SoCalGas and SDG&E's Preliminary Electrical Contractor Estimate (*confidential*): SoCalGas and SDG&E's preliminary cost estimate for construction was [REDACTED].
4. Electrical Contractor's Estimate (*confidential*): The Electrical Contractor's estimate was [REDACTED], which was [REDACTED] than SoCalGas and SDG&E's preliminary cost estimate.

Pipeline Safety Enhancement Plan Final Report
Alhambra Station Valve Enhancement Project

B. Construction Schedule

Table 3: Construction Timeline

Construction Start Date	04/20/2015
Construction Completion Date	08/19/2015
Days on Site	71 days
Commissioning Date	11/04/2015

The Project Team completed all construction activities as soon as practicable prior to commissioning. SoCalGas and SDG&E’s finalization of commissioning activities is dependent on electrical utility connections, and system and/or resource availability.

C. Changes During Construction

The conditions summarized below were encountered during construction. Activities to address or mitigate these conditions resulted in approximately \$144,000 in change orders.

1. Additional Support: On the day of the second tie-in, the SoCalGas and SDG&E directed the Mechanical Construction Contractor to provide additional support when purging and monitoring the pipeline and to excavate an additional trench from the electrical panel to the electrical pedestal.
2. Field Design Change: The Project Team designed the blow-off stack to be above-grade; however, to provide additional protection to the blow-off stack from vehicular traffic, the Project Team moved the blow-off stack below-grade inside a new vault.

Pipeline Safety Enhancement Plan Final Report
Alhambra Station Valve Enhancement Project

3. Substructures: During excavation, crews encountered a previously unidentified waterline that interfered with the placement of the flowmeter vault. The Project Team worked with the local water utility to reroute the waterline, and installed the vault as designed.
4. Environmental Abatement: During excavation, the Mechanical Construction Contractor encountered a layer of asbestos approximately 4 feet and 6 inches below-grade. Abatement crews were required to remove, test and dispose of the material.
5. Schedule Delay: Standby delay was due to the abatement of the previously mentioned asbestos.

Pipeline Safety Enhancement Plan Final Report
Alhambra Station Valve Enhancement Project

Figure 4: Alhambra Station Valve Enhancement Project – New Valve Assembly



Pipeline Safety Enhancement Plan Final Report
Alhambra Station Valve Enhancement Project

D. Commissioning and Site Restoration

Commissioning activities included site restoration, final inspections, and placement of the valves into service. During this stage, SoCalGas and SDG&E successfully performed site acceptance testing and conducted point-to-point verification with SoCalGas Gas Control personnel for the newly-automated valves. SoCalGas and SDG&E trained Field Operations personnel on the proper use and operation of the new equipment. Closeout activities included development of final drawings, the reconciliation package, and updates to company recordkeeping systems to reflect the completed scope of work. The sites were commissioned on November 4, 2015, as summarized in Table 3.

Pipeline Safety Enhancement Plan Final Report
Alhambra Station Valve Enhancement Project

IV. PROJECT COSTS

A. Cost Avoidance Actions

SoCalGas and SDG&E exercised due diligence in the design, planning, and construction activities for this project to minimize or avoid costs when prudent to do so. As discussed above, the Project Team reviewed existing records, communicated with external stakeholders, and conducted a pre-design site walk to incorporate the known site conditions in the project plan and design. Specific examples of cost avoidance actions taken on this project were:

1. Land Use: The Project Team performed the work within a company facility. The work space was limited to inside the station only, preventing the Project from incurring any costs for a Temporary Right of Entry (TRE) or a laydown yard.
2. Planning and Coordination: Construction during November through February would have required a test shut-in of ID450-T, so the Project Team started construction in April, in order to avoid the cost of the test shut-in, as well as to avoid the need for an additional temporary bypass or CNG/LNG support.

Pipeline Safety Enhancement Plan Final Report
Alhambra Station Valve Enhancement Project

B. Cost Estimates

Based on the preliminary design, once the preliminary project scope was confirmed and engineering, design, and planning activities were underway, SoCalGas and SDG&E prepared an estimate of the Direct Costs of the Project in the amount of \$2,541,185. This estimate was prepared in May of 2014, using the “Stage 3 SCG Valve Estimate Template Rev 0” estimating tool, the most current version of the PSEP Estimate Template at the time. The Project Team considered the conditions known at the time to prepare the preliminary Direct Cost estimate. This estimate reflects the projected Labor, Material, and Services costs anticipated to be incurred to execute the Project, based on initial design plans.

SoCalGas and SDG&E estimated Indirect Costs of the Project based on the estimated Direct Costs and other project-related variables.

C. Actual Direct and Indirect Costs

Actual Direct Costs reflect the Labor, Material, and Services costs incurred to execute the Project. Actual Indirect Costs reflect costs for incremental overhead loaders in accordance with Company overhead allocation policies. The total loaded cost of the Project is \$3,587,677.

Pipeline Safety Enhancement Plan Final Report
Alhambra Station Valve Enhancement Project

Table 4: Estimated and Actual Direct Costs and Variances

Direct Costs (\$)	Estimate	Actuals	Delta Over/(Under)
Company Labor	158,739	200,125	41,386
Materials	401,812	287,793	(114,019)
Mechanical Construction Contractor	888,222	860,739	(27,483)
Electrical Contractor	115,937	189,370	73,433
Construction Management & Support	151,416	482,833	331,417
Environmental	13,552	93,307	79,755
Engineering & Design	384,259	487,770	103,511
Project Management & Services	147,668	177,392	29,724
ROW & Permits	11,000	-	(11,000)
GMA	268,580	361,367	92,787
Total Direct Costs	2,541,185	3,140,696	599,511

Table 5: Estimated and Actual Indirect Costs, Total Costs, and Variances

Indirect Costs/Total Costs (\$)	Estimate	Actuals	Delta Over/(Under)
Overheads	351,275	312,992	(38,283)
AFUDC	91,614	118,974	27,360
Property Taxes	17,820	15,015	(2,805)
Total Indirect Costs	460,709	446,981	(13,728)
Total Direct Costs	2,541,185	3,140,696	599,511
Total Loaded Costs	3,001,894	3,587,677	585,783

Pipeline Safety Enhancement Plan Final Report
Alhambra Station Valve Enhancement Project

V. CONCLUSION

SoCalGas and SDG&E enhanced the safety of their integrated natural gas system by prudently executing the Alhambra Station Valve Enhancement Project. Through this Valve Enhancement Project, SoCalGas and SDG&E successfully installed two mainline valves to achieve the objective of enabling rapid system isolation in the City of Alhambra. The total loaded cost of the Project is \$3,587,677.

SoCalGas and SDG&E executed this project prudently through designing and executing the Project to support achievement of Valve Enhancement Plan isolation objectives, and by responding to unanticipated field changes by working with the local water utility to relocate an existing water line.

SoCalGas and SDG&E engaged in prudent cost avoidance efforts to complete this safety enhancement at a reasonable cost by careful planning and coordination of construction activities that prevented extra mobilizations, by utilizing an existing SoCalGas facility as a laydown yard; avoiding any customer impacts during two planned blowdowns, engaging in reasonable efforts to promote competitive and market-based rates for contractor services and materials, and using a reasonable amount of company and contractor resources so as to complete the safety enhancement work as soon as practicable.

End of Alhambra Station Valve Enhancement Project Final Report

Pipeline Safety Enhancement Plan Final Report
Aviation and Boardwalk Valve Enhancement Project

I. AVIATION AND BOARDWALK VALVE ENHANCEMENT PROJECT

A. Background and Summary

This report describes the activities associated with the Aviation and Boardwalk Valve Enhancement Project that consists of valve enhancements made to two new mainline valves (MLVs) in the Cities of Hawthorne and El Segundo. Through this project, SoCalGas and SDG&E enhanced the capabilities of two MLVs to enable transmission system isolation to a portion of Lines 1170 and 1175. SoCalGas and SDG&E relocated Lines 1170 and 1175, installed two new mainline valves, two new actuators, two new vaults to house the actuators, a new blowdown assembly, new power equipment, new communications equipment, and the necessary automation equipment at the sites. The total loaded project cost is \$7,397,299.

This project site is in a high-density, urban environment that is a mix of residential and commercial. Lines 1170 and 1175 are beneath the heavily trafficked Aviation Boulevard. Aviation Boulevard is the border between the Cities of Hawthorne and El Segundo, and construction activities will impact both cities.

Pipeline Safety Enhancement Plan Final Report
Aviation and Boardwalk Valve Enhancement Project

Table 1: General Project Information

Aviation and Boardwalk Valve Enhancement Project			
Location	Hawthorne and El Segundo		
Days on Site	127 days		
Construction Start	06/06/2016		
Construction Finish	01/18/2017		
Commissioning Date	09/27/2017		
Valve Upgrades			
Valve Number	1170-1.93-0		
Valve Type	New – Ball		
Actuator	New		
Actuator Above/Below-Grade	Below-Grade		
ASV	Yes		
RCV	Yes		
Valve Number	1175-1.93-0		
Valve Type	New – Ball		
Actuator	New		
Actuator Above/Below-Grade	Below-Grade		
ASV	Yes		
RCV	Yes		
Site Upgrades			
Vault	New		
Power	New – Utility		
Communication	New – Radio		
SCADA Panel	New		
Equipment Shelter	None		
Wall	New – Retaining Wall		
Project Costs (\$)	Capital	O&M	Total
Loaded Project Costs	7,397,299	-	7,397,299
Disallowed Costs	-	-	-

Pipeline Safety Enhancement Plan Final Report
Aviation and Boardwalk Valve Enhancement Project

B. Maps and Images

Figure 1: Satellite Image of Aviation and Boardwalk Valve Enhancement Project

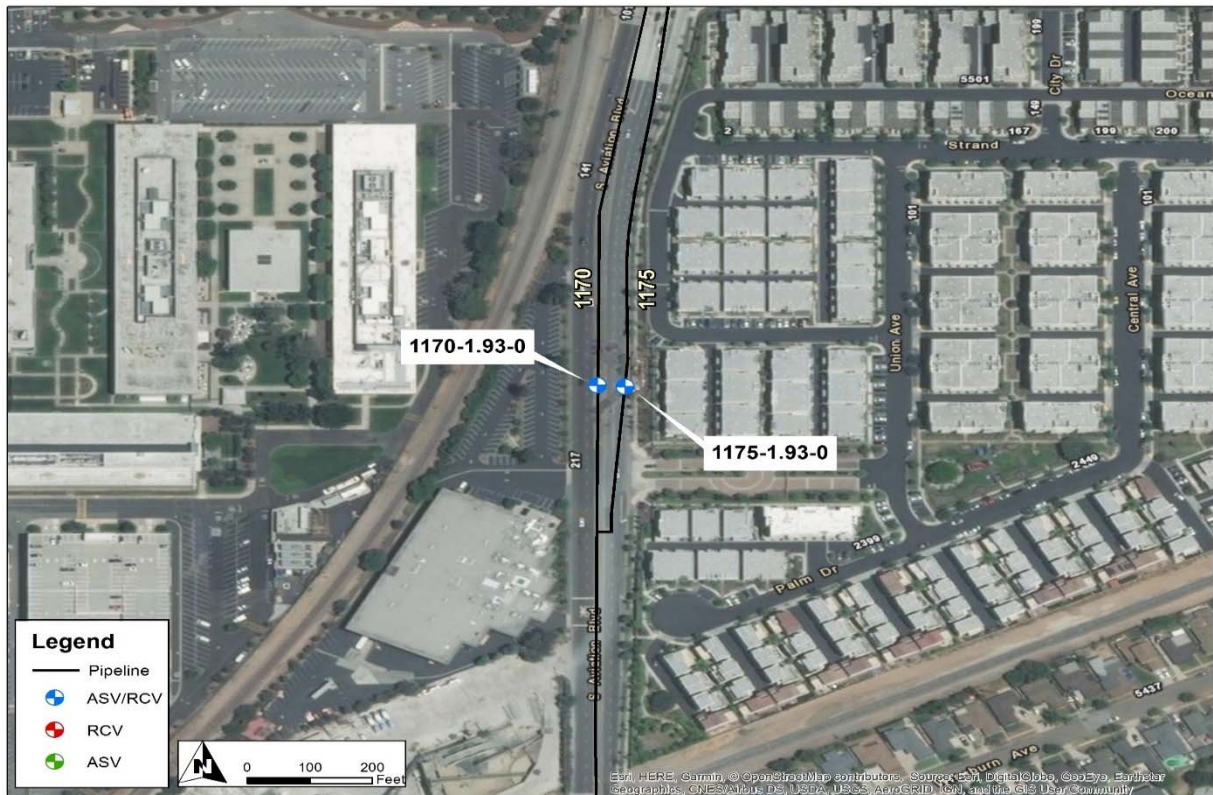

Pipeline Safety Enhancement Plan Final Report
Aviation and Boardwalk Valve Enhancement Project

II. ENGINEERING, DESIGN, AND PLANNING

A. Project Scope

SoCalGas and SDG&E presented a conceptual project scope in workpapers supporting the Valve Enhancement Plan¹ in the 2011 filing. This conceptual scope identified MLVs 1170-1.98-0 and 1175-1.98-0, for automation to provide remote isolation to a portion of Lines 1170 and 1175. Prior to initiating execution of the Project, SoCalGas and SDG&E reviewed available information and performed a detailed system flow analysis to validate the scope of the Project that confirmed that this enhancement will provide the planned isolation. The final project scope is summarized in Table 2 below.

1. 2011 PSEP Filing: SoCalGas and SDG&E identified MLVs 1170-1.98-0 and 1175-1.98-0 for automation to achieve the objective of rapid system isolation.
2. Updated Scope: Upon project initiation, SoCalGas and SDG&E reviewed the conceptual project scope and determined that automation of MLVs 1170-1.98-0 and 1175-1.95-0 would achieve the transmission isolation objectives set forth in the Valve Enhancement Plan.

¹ See Workpapers supporting Amended Pipeline Safety Enhancement Plan (PSEP) of SoCalGas and SDG&E, submitted on December 2, 2011, at WP-IX-2-14 through WP-IX-2-25 (A.11-11-002 Exh. # SCG-32).

Pipeline Safety Enhancement Plan Final Report
Aviation and Boardwalk Valve Enhancement Project

3. Engineering, Design, and Constructability: The existing MLVs 1170-1.98-0 and 1175-1.98-0 are located in the street underneath Aviation Boulevard. The valves would require relocation out of the street to be automated. There were two existing spools used to install temporary pig launchers next to these valves. The relocation of these valves would have interfered with these spools and future In-line Inspection activities. Additionally, there was not sufficient space to relocate these valves in this area. The Project Team determined that the installation of two new MLVs near this location would achieve the same isolation objectives and would result in lower construction costs. The Project Team proceeded to install new MLVs 1170-1.93-0 and 1175-1.93-0.

4. Final Project Scope: The final project scope consists of the relocation of Lines 1170 and 1175, installation of two new MLVs, two new actuators, two new vaults to house the actuators, a new blowdown assembly, the installation of power equipment, the installation of communications equipment, and the installation of the necessary automation equipment at the project site.

Table 2: Final Project Scope

Final Project Scope					
Line	Mile	Valve #	Valve Size (<i>confidential</i>)	Installation Type	Function
1170	1.93	0		NV/VT	ASV/RCV
1175	1.93	0		NV/VT	ASV/RCV

Pipeline Safety Enhancement Plan Final Report
Aviation and Boardwalk Valve Enhancement Project

B. Site Evaluation and Planning

SoCalGas and SDG&E initiated the planning process for the Aviation and Boardwalk Valve Enhancement Project by performing a pre-design site walk to determine existing conditions and assess any potential impacts on the design. Key factors that influenced the engineering and design of this project are as follows:

1. Site Description: The site is located in a high-density, residential and commercial area. The pipelines are beneath the heavily trafficked Aviation Boulevard. There is a condominium development along one side of the street.
2. Land Issues: The Project Team noted that excavations will impact traffic on Aviation Boulevard, the adjacent sidewalk, and the landscaping of the neighboring condominium development.
3. DOT Class: This project site is in a Class 3 location.
4. Power Source: There was no preexisting power source, the Project Team installed new power equipment at the site.
5. Communication Technology: There was no preexisting communications equipment, the Project Team installed new communications equipment at the site.

C. Engineering, Design, and Planning Factors

SoCalGas and SDG&E reviewed drawings and records, contacted internal planning groups, communicated with external stakeholders, conducted survey activity, performed potholing of the area to identify the presence of underground utilities and substructures, and completed a pre-design site walk. Key factors that influenced the engineering and design of the Project are as follows:

Pipeline Safety Enhancement Plan Final Report
Aviation and Boardwalk Valve Enhancement Project

1. Engineering Assessment: During the site evaluation, the Project Team confirmed the location of the existing valves and verified that the automation of the existing valves would require relocating the valves out of the street. There is a removable spool (a flanged section of pipe) where a temporary launcher is installed during pigging operations. The Project Team noted that this spool would be impacted if the valves were relocated and any relocation would require the installation of a new spool. Additionally, there was not sufficient space around these valves to relocate them out of the street. The Project Team determined that the installation of two valves nearby would achieve the same isolation objectives.
2. Valve Details:
 - a. 1170-1.93-0: There was no existing valve, the Project Team installed a new Class 600 ball valve.
 - b. 1175-1.93-0: There was no existing valve, the Project Team installed a new Class 600 ball valve.
3. Actuator Details:
 - a. 1170-1.93-0: There was no preexisting actuator, the Project Team installed a new actuator.
 - b. 1175-1.93-0: There was no preexisting actuator, the Project Team installed a new actuator.

Pipeline Safety Enhancement Plan Final Report
Aviation and Boardwalk Valve Enhancement Project

4. Customer Impact: The relocation of the pipeline and the installation of the new valves required a blowdown of Lines 1170 and 1175. Customers serviced by these two lines can be serviced by other lines. The Project Team did not anticipate service disruptions to customers.
5. Community Impact: The Project Team worked with the condominium association to verify that the restoration efforts were completed per the agreed specifications. The Project Team also maintained public access to the sidewalk during construction.
6. Substructures: The Project Team performed potholing to verify the route and required depth of the new pipeline offset. Aside from the existing pipeline, the Project Team identified no substructures during this phase that would affect the design.
7. Environmental: There was concern of landfill gas being present in the soil. The Project Team monitored air quality during excavation.
8. Permit Restrictions: Aviation Boulevard is the border between the City of Hawthorne and the City of El Segundo. The Project Team obtained traffic control permits from both municipalities. The Project Team also obtained a permit from the City of Hawthorne's Building and Safety Department for the new retaining wall that was installed per the request of the condominium association.
9. Land Use: The Project Team utilized the laydown yard for Aviation Boulevard & 104th Street Valve Enhancement Project. SoCalGas and SDG&E obtained a new easement from the condominium association.
10. Traffic Control: Aviation Boulevard is the border between the City of Hawthorne and the City of El Segundo. Aviation Boulevard was partially closed during construction.

Pipeline Safety Enhancement Plan Final Report
Aviation and Boardwalk Valve Enhancement Project

Figure 2: Aviation and Boardwalk Valve Enhancement Project Bundle

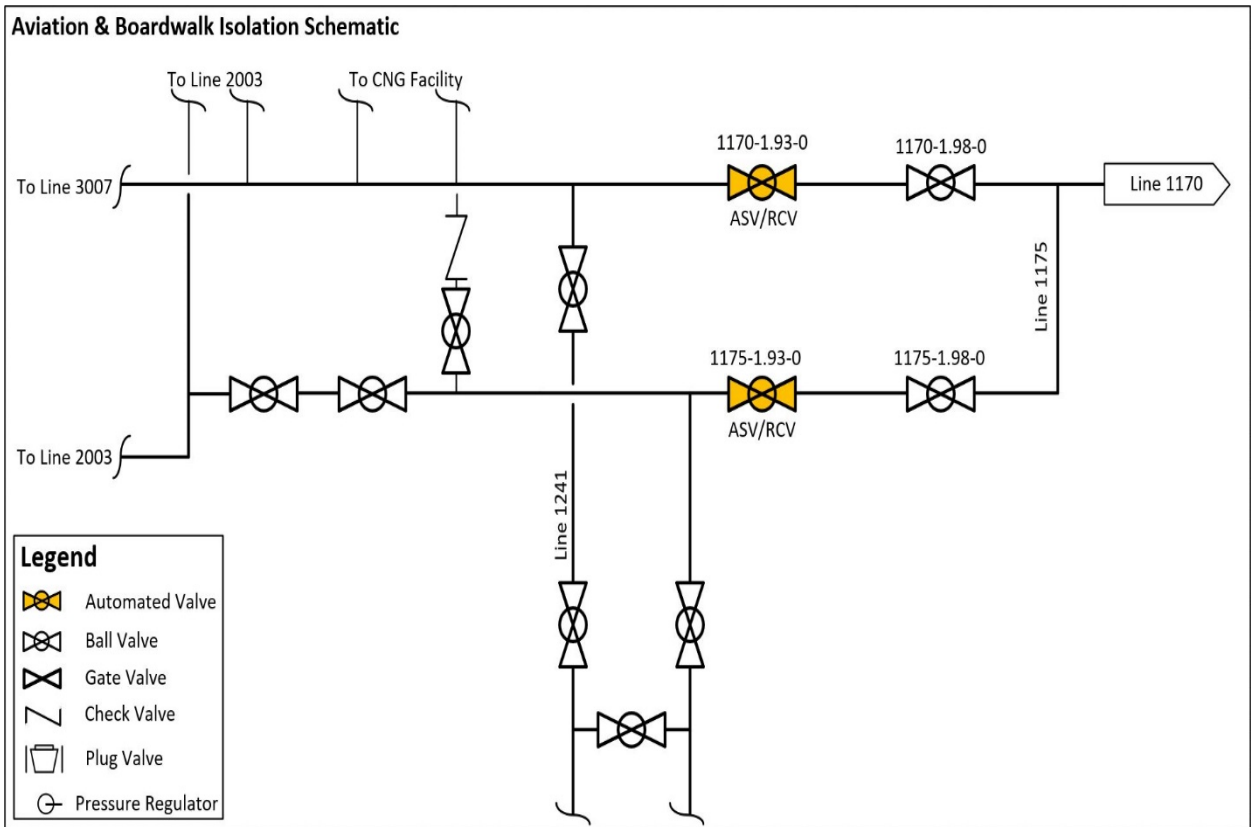

Pipeline Safety Enhancement Plan Final Report
Aviation and Boardwalk Valve Enhancement Project

D. Scope Changes

SoCalGas and SDG&E did not make any notable scope changes during detailed design.

Pipeline Safety Enhancement Plan Final Report
Aviation and Boardwalk Valve Enhancement Project

III. CONSTRUCTION

A. Construction Contractor Selection

The Project Team prepared an initial cost estimate based on the preliminary design. Following completion of the engineering, design, and planning activities described above, the Project Team entered into a competitive bidding process to select a Mechanical Construction Contractor, and directed the Alliance Partner (Electrical Contractor) to prepare cost an estimate based on a more detailed engineering design package. As indicated above, there were no notable changes in scope between the time when the Project Team prepared the preliminary cost estimate and when the Performance Partner and Alliance Partner prepared and submitted their estimates.

1. SoCalGas and SDG&E's Preliminary Mechanical Construction Contractor Estimate (confidential): SoCalGas and SDG&E's preliminary cost estimate for construction was [REDACTED]
2. Mechanical Construction Contractor's Estimate (confidential): The Mechanical Construction Contractor's cost estimate was [REDACTED], that was [REDACTED] than SoCalGas and SDG&E's preliminary cost estimate for construction.
3. SoCalGas and SDG&E's Preliminary Electrical Contractor Estimate (confidential): SoCalGas and SDG&E's preliminary cost estimate for construction was [REDACTED]
4. Electrical Contractor's Estimate (confidential): The Electrical Contractor's estimate was [REDACTED], which was [REDACTED] than SoCalGas and SDG&E's preliminary cost estimate.

Pipeline Safety Enhancement Plan Final Report
Aviation and Boardwalk Valve Enhancement Project

B. Construction Schedule

Table 3: Construction Timeline

Construction Start Date	06/06/2016
Construction Completion Date	01/18/2017
Days on Site	127 days
Commissioning Date	09/27/2017

The Project Team completed all construction activities as soon as practicable prior to commissioning. SoCalGas and SDG&E’s finalization of commissioning activities is dependent on electrical utility connections, and system and/or resource availability.

C. Changes During Construction

The conditions summarized below were encountered during construction. Activities to address or mitigate these conditions resulted in approximately \$256,000 in change orders.

1. Scheduling:

- a. The Project Team identified a previously unidentified drainage pipe that required additional work and resulted in a schedule delay.

Pipeline Safety Enhancement Plan Final Report
Aviation and Boardwalk Valve Enhancement Project

- b. Construction was extended beyond what the Mechanical Construction Contractor assumed in the bid due to conditions encountered during construction. These conditions include the previously unidentified drainage pipe discussed above and below, the time required to obtain an additional Traffic Control Permit, the extension of tie-in activities, the additional excavation work performed for the Electrical Contractor, the additional restoration costs, and the safety monitor discussed below.
 - c. The City of El Segundo required an additional traffic control permit resulting in a change in the Traffic Control Plan.
2. Tie-In: The Project Team initially planned for 16 hours per tie-in. Due to complex gas handling and isolation activities, the tie-in for Line 1170 took 29 hours and the tie-in for Line 1175 took 24 hours.
3. Construction Method:
- a. The Mechanical Construction Contractor performed all excavations including those related to the electrical work..
 - b. The Project Team requested that the Mechanical Construction Contractor excavate and build the foundation pads for the new cabinets and antenna pole.

Pipeline Safety Enhancement Plan Final Report
Aviation and Boardwalk Valve Enhancement Project

4. Restoration:
 - a. The condominium association requested that SoCalGas and SDG&E install safety rails around the new retaining wall.
 - b. The City of Hawthorne requested that rubberized asphalt be utilized when restoring the street.
5. Field Design Change: The Project Team determined a previously unidentified drainage pipe during excavations. The Project Team removed and later restored this drainage pipe.
6. Safety: The Project Team requested that the Mechanical Construction Contractor provide a dedicated safety monitor during construction.

Pipeline Safety Enhancement Plan Final Report
Aviation and Boardwalk Valve Enhancement Project

Figure 3: New Mainline Valves After the Tie-in with New Actuators



Pipeline Safety Enhancement Plan Final Report
Aviation and Boardwalk Valve Enhancement Project

D. Commissioning and Site Restoration

Commissioning activities included site restoration, final inspections, and placement of the valves into service. During this stage, SoCalGas and SDG&E successfully performed site acceptance testing and conducted point-to-point verification with SoCalGas Gas Control personnel for the newly-automated valves. SoCalGas and SDG&E trained Field Operations personnel on the proper use and operation of the new equipment. Closeout activities included development of final drawings, the reconciliation package, and updates to company recordkeeping systems to reflect the completed scope of work. The site was commissioned on September 27, 2017 as summarized in Table 3.

Pipeline Safety Enhancement Plan Final Report
Aviation and Boardwalk Valve Enhancement Project

IV. PROJECT COSTS

A. Cost Avoidance Actions

SoCalGas and SDG&E exercised due diligence in the design, planning, and construction activities for this project to minimize or avoid costs when prudent to do so. As discussed above, the Project Team reviewed existing records, communicated with external stakeholders, and conducted a site walk to incorporate known site conditions in the project plan and design. Specific examples of cost avoidance actions taken on this project were:

1. Planning and Coordination: SoCalGas and SDG&E coordinated engineering activities with the 104th and Aviation Valve Enhancement Project to reduce the overall cost for customers.
2. Land Use: The Project Team utilized the laydown yard for the 104th and Aviation Valve Enhancement Project for this Project as well, avoiding the cost of obtaining an additional temporary easement for a laydown yard.

Pipeline Safety Enhancement Plan Final Report
Aviation and Boardwalk Valve Enhancement Project

B. Cost Estimates

Based on the preliminary design, once the preliminary project scope was confirmed and engineering, design, and planning activities were underway, SoCalGas and SDG&E prepared an estimate of the Direct Costs of the Project in the amount of \$3,797,533. This estimate was prepared in June of 2015, using the “Stage 3 SCG Valve Estimate Template Rev 1” estimating tool, the most current version of the PSEP Estimate Template at the time. The Project Team considered the conditions known at the time to prepare the preliminary Direct Cost estimate. This estimate reflects the projected Labor, Material, and Services costs anticipated to be incurred to execute the Project, based on initial design plans.

SoCalGas and SDG&E estimated Indirect Costs of the Project based on the estimated Direct Costs and other project-related variables.

C. Actual Direct and Indirect Costs

Actual Direct Costs reflect the Labor, Material, and Services costs incurred to execute the Project. Actual Indirect Costs reflect costs for incremental overhead loaders in accordance with Company overhead allocation policies. The total loaded cost of the Project is \$7,397,299.

Pipeline Safety Enhancement Plan Final Report
Aviation and Boardwalk Valve Enhancement Project

Table 4: Estimated and Actual Direct Costs and Variances

Direct Costs (\$)	Estimate	Actuals	Delta Over/(Under)
Company Labor	277,756	273,412	(4,344)
Materials	586,768	354,815	(231,953)
Mechanical Construction Contractor	1,623,155	3,516,516	1,893,361
Electrical Contractor	107,660	84,413	(23,247)
Construction Management & Support	136,614	250,503	113,889
Environmental	15,785	40,316	24,531
Engineering & Design	181,436	806,675	625,239
Project Management & Services	243,694	240,169	(3,525)
ROW & Permits	223,300	258,517	35,217
GMA	401,365	729,221	327,856
Total Direct Costs	3,797,533	6,554,557	2,757,024

Table 5: Estimated and Actual Indirect Costs, Total Costs, and Variances

Indirect Costs/Total Costs (\$)	Estimate	Actuals	Delta Over/(Under)
Overheads	1,285,703	588,508	(697,195)
AFUDC	881,364	116,219	(765,145)
Property Taxes	187,613	138,015	(49,598)
Total Indirect Costs	2,354,680	842,742	(1,511,938)
Total Direct Costs	3,797,533	6,554,557	2,757,024
Total Loaded Costs	6,152,213	7,397,299	1,245,086

Pipeline Safety Enhancement Plan Final Report
Aviation and Boardwalk Valve Enhancement Project

V. CONCLUSION

SoCalGas and SDG&E enhanced the safety of their integrated natural gas system by prudently executing the Aviation and Boardwalk Valve Enhancement Project. Through this Valve Enhancement Project, SoCalGas and SDG&E successfully installed two new automated mainline valves to achieve the objective of enabling rapid system isolation in the Cities of Hawthorne and El Segundo. The total loaded cost of the Project is \$7,397,299.

SoCalGas and SDG&E executed this project prudently through designing and executing the Project to support the achievement of Valve Enhancement Plan isolation objectives, coordinating the engineering of two valve projects, installing two new mainline valves, two new actuators, two new vaults to house the actuators, and installing equipment necessary to bring power and communication capabilities to these valves to enable rapid system isolation to a portion of Lines 1170 and 1175.

SoCalGas and SDG&E engaged in prudent cost avoidance efforts to complete this safety enhancement project at a reasonable cost by carefully planning and coordinating construction activities to minimize the impact to the community, and by scheduling the tie-in to prevent service interruptions to customers limiting the number of mobilizations and reducing costs for customers.

End of Aviation and Boardwalk Valve Enhancement Project Final Report

Pipeline Safety Enhancement Plan Final Report
Line 5000 Banning Valve Enhancement Project Bundle

I. LINE 5000 BANNING VALVE ENHANCEMENT PROJECT BUNDLE

A. Background and Summary

This report describes the activities associated with the Line 5000 Banning Valve Enhancement Project Bundle, that consists of valve enhancements made to two existing mainline valves (MLVs) located in the City of Banning and in Riverside County. Through this project, SoCalGas and SDG&E enhanced the capabilities of two MLVs to enable rapid transmission system isolation to a portion of Line 5000. SoCalGas and SDG&E installed a new block wall, new power equipment, new communications equipment, and the necessary automation equipment at the sites. The total loaded project cost is \$2,409,544.

The two valves comprising the Line 5000 Banning Valve Enhancement Project Bundle are separated into two sites. The MLV 14B site is an existing SoCalGas facility on Highland Springs Avenue in a high-density residential area in the City of Banning. A block wall encloses the existing facility. The MLV 14.6B site is an existing SoCalGas facility in a remote, rural area in Riverside County.

Pipeline Safety Enhancement Plan Final Report Line 5000 Banning Valve Enhancement Project Bundle

Table 1: General Project Information

Line 5000 Banning Valve Enhancement Project Bundle			
Site	MLV 14B	MLV 14.6B	
Location	City of Banning	Riverside County	
Days on Site	49 days	32 days	
Construction Start	10/14/2015	06/27/2016	
Construction Finish	12/31/2015	10/06/2016	
Commissioning Date	02/19/2016	04/11/2017	
Valve Upgrades			
Valve Number	5000-147.04-0	5000-153.98-0	
Valve Type	Existing – Ball	Existing – Ball	
Actuator	Existing	Existing	
Actuator Above-/Below-Grade	Above	Above	
ASV	Yes	Yes	
RCV	Yes	Yes	
Site Upgrades			
Vault	None	None	
Power	New – Solar	New – Solar	
Communication	New – Radio	New – Radio	
SCADA Panel	New	New	
Equipment Shelter	New	None	
Wall	Existing	New	
Project Costs (\$)	Capital	O&M	Total
Loaded Project Costs	2,409,544	-	2,409,544
Disallowed Costs	-	-	-

Pipeline Safety Enhancement Plan Final Report
Line 5000 Banning Valve Enhancement Project Bundle

B. Maps and Images

Figure 1: Satellite Image of Line 5000 Banning Valve Enhancement Project Bundle:
Overview



Pipeline Safety Enhancement Plan Final Report Line 5000 Banning Valve Enhancement Project Bundle

Figure 2: MLV 14B



Pipeline Safety Enhancement Plan Final Report Line 5000 Banning Valve Enhancement Project Bundle

Figure 3: MLV 14.6B

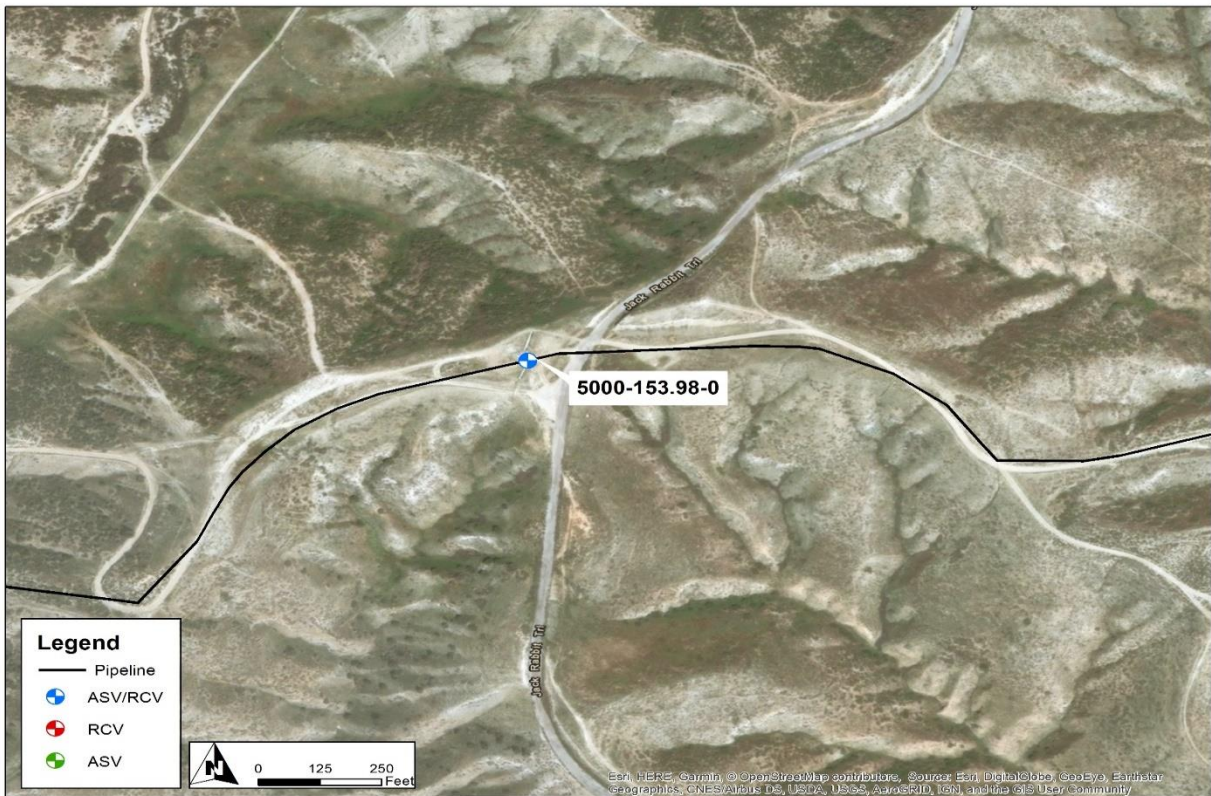

Pipeline Safety Enhancement Plan Final Report
Line 5000 Banning Valve Enhancement Project Bundle

II. ENGINEERING, DESIGN, AND PLANNING

A. Project Scope

SoCalGas and SDG&E presented a conceptual project scope in workpapers supporting the Valve Enhancement Plan¹ in the 2011 filing. This conceptual scope identified MLV's 5000-147.04-0 and 5000-153.98-0 for automation to provide remote isolation to a portion of Line 5000. Prior to initiating execution of the Project, SoCalGas and SDG&E reviewed available information and performed a detailed system flow analysis to validate the scope of the Project, that confirmed that these valve enhancements will provide the planned isolation. The final project scope is summarized in Table 2 below.

1. 2011 PSEP Filing: SoCalGas and SDG&E identified two MLVs for automation to achieve the objective of rapid system isolation.
2. Updated Scope: Upon project initiation, SoCalGas and SDG&E reviewed the conceptual project scope and determined that these isolation points achieve the transmission isolation objectives set forth in the Valve Enhancement Plan.
3. Engineering, Design, and Constructability:
 - a. The Project Team determined that the existing blowdown assembly at the MLV 14B site would need to be redesigned to accommodate the new automation equipment.
 - b. The Project Team had initially planned to install utility power at the MLV 14B site. The location of the utility power would have resulted in higher costs due to trenching. Solar power was installed instead.

¹ See Workpapers supporting Amended Pipeline Safety Enhancement Plan (PSEP) of SoCalGas and SDG&E, submitted on December 2, 2011, at WP-IX-2-14 through WP-IX-2-25 (A.11-11-002 Exh. # SCG-32).

Pipeline Safety Enhancement Plan Final Report
Line 5000 Banning Valve Enhancement Project Bundle

4. **Final Project Scope:** The final project scope consists of the automation of two MLVs, that includes the installation of a new block wall at the MLV 14.6B, the installation of solar power equipment at the MLV 14B site, the installation of additional solar power equipment at the MLV 14.6B site, the installation of communications equipment, and the installation of the necessary automation equipment at the project sites.

Table 2: Final Project Scope

Final Project Scope					
Line	Mile	Valve #	Valve Size (<i>confidential</i>)	Installation Type	Function
5000	147.04	0	[REDACTED]	C/P	ASV/RCV
5000	153.98	0	[REDACTED]	C/P	ASV/RCV

B. Site Evaluation and Planning

SoCalGas and SDG&E initiated the planning process for the Line 5000 Banning Valve Enhancement Project Bundle by performing a pre-design site walk to determine the existing conditions and assess any potential impacts on the design. Key factors that influenced the engineering and design of this project are as follows:

MLV 14B

1. **Site Description:** This site is an existing SoCalGas facility located in a high-density, residential area. A block wall encloses the facility. There is a preexisting blowdown assembly and blowdown silencer within the facility.
2. **Land Issues:** During the pre-design site walk, the Project Team noted that the existing facility can accommodate the new equipment.
3. **DOT Class:** This project is in a Class 3 location.

Pipeline Safety Enhancement Plan Final Report
Line 5000 Banning Valve Enhancement Project Bundle

4. Power Source: There was existing power source, the Project Team installed new power equipment at the site to accommodate the increased loads from the necessary automation equipment.
5. Communication Technology: There was no preexisting communications equipment, the Project Team installed new communications equipment at the site.

MLV 14.6B

1. Site Description: This site is an existing SoCalGas facility in a remote rural area. There is no access to utility power. There is an existing blowdown assembly within the facility.
2. Land Issues: During the pre-design site walk, the Project Team noted the existing station would need to be expanded to accommodate the additional equipment.
3. DOT Class: This project is in a Class 1 location. SoCalGas and SDG&E selected this MLV for automation to isolate an HCA upstream of the valve and known geological threat downstream of the valve.
4. Power Source: There was existing power source, the Project Team installed new power equipment at the site to accommodate the increased loads from the necessary automation equipment.
5. Communication Technology: There was no preexisting communications equipment, the Project Team installed new communications equipment at the site.

Pipeline Safety Enhancement Plan Final Report
Line 5000 Banning Valve Enhancement Project Bundle

C. Engineering, Design, and Planning Factors

SoCalGas and SDG&E reviewed drawings and records, contacted internal planning groups, communicated with external stakeholders, conducted survey activity, and completed a pre-design site walk. Key factors that influenced the engineering and design of the Project are as follows:

MLV 14B

1. Engineering Assessment: During the site evaluation, the Project Team confirmed the preexisting technology and verified that the station could accommodate the new equipment. The Project Team determined that the preexisting blowdown silencer required relocation to allow adequate spacing within the confines of the existing block wall for the new automation equipment.
2. Valve Details: The existing valve was a manually actuated Class 400 ball valve that the Project Team reused.
3. Actuator Details: The existing actuator was a double-acting pneumatic actuator that the Project Team reused.
4. Customer Impact: The Project Team did not anticipate service disruptions to customers.
5. Community Impact: The Project Team did not anticipate any notable impact to the community from this project.
6. Substructures: The Project Team did not identify any existing substructures that affected the design and engineering at this site.

Pipeline Safety Enhancement Plan Final Report
Line 5000 Banning Valve Enhancement Project Bundle

7. Environmental: The Project Team did not identify any notable environmental concerns at the site. An environmental monitor performed spot checks during construction.
8. Permit Restrictions: There were no special permit restrictions for this project site.
9. Land Use: The Project Team performed all work within an existing SoCalGas facility.
10. Traffic Control: The Project Team did not identify any traffic control needs at the site.

MLV 14.6B

1. Engineering Assessment: During the site evaluation, the Project Team confirmed the existing technology and verified the need to expand the existing station to accommodate the new equipment. Due to the location of the facility and the related security concerns, the Project Team constructed a block wall around the installation. The Operating District paid for the block wall.
2. Valve Details: The existing valve was a manually actuated Class 400 ball valve that the Project Team reused.
3. Actuator Details: The existing pneumatic actuator was compatible with PSEP linebreak technology and was reused.
4. Customer Impact: The Project Team did not anticipate service disruptions to customers.
5. Community Impact: The Project Team did not anticipate any notable impact to the community from this project.

Pipeline Safety Enhancement Plan Final Report
Line 5000 Banning Valve Enhancement Project Bundle

6. Substructures: The Project Team did not identify any existing substructures that affected the design and engineering at this site.
7. Environmental: The Project Team completed a biological survey prior to construction activities. An environmental monitor was on-site daily when the excavation was open. The environmental monitor performed spot checks during construction when the excavation was closed.
8. Permit Restrictions: The Project Team obtained a Building Permit from Riverside County for the installation of the block wall.
9. Land Use: The Project Team obtained temporary right of entry (TRE) for construction.
10. Traffic Control: The Project Team did not identify any traffic control needs at the site.

Pipeline Safety Enhancement Plan Final Report Line 5000 Banning Valve Enhancement Project Bundle

Figure 4: Line 5000 Banning Valve Enhancement Project Bundle Schematic

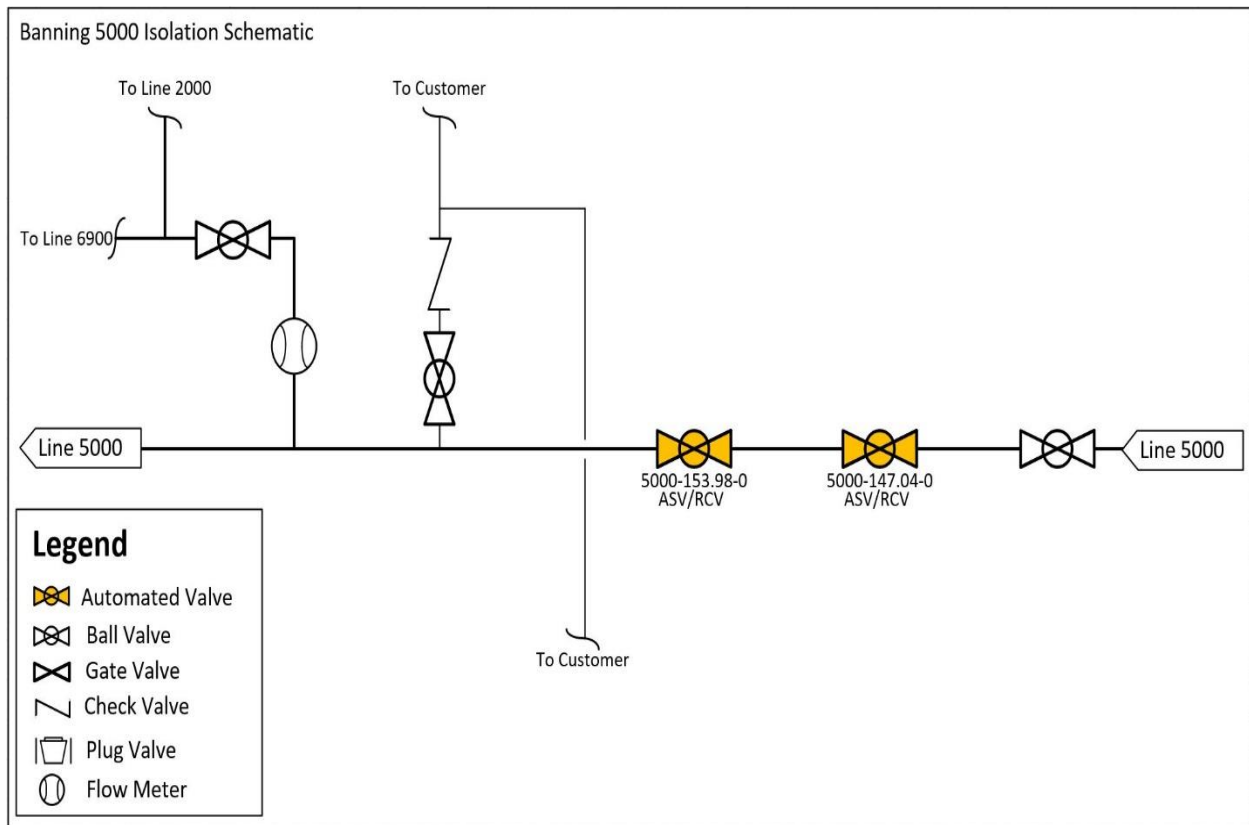

Pipeline Safety Enhancement Plan Final Report
Line 5000 Banning Valve Enhancement Project Bundle

D. Scope Changes

Through engineering, design, and planning activities, SoCalGas and SDG&E determined that changes in scope were appropriate to enhance the design of the Project and address engineering factors. As a result, the preliminary cost estimate does not fully reflect the final scope. The Project Team initially planned to install utility power at the MLV 14B site. During the design phase, the Project Team determined that utility power installation would have resulted in higher construction costs and adjusted the design to utilize solar power.

Pipeline Safety Enhancement Plan Final Report
Line 5000 Banning Valve Enhancement Project Bundle

III. CONSTRUCTION

A. Construction Contractor Selection

The Project Team prepared an initial cost estimate based on the preliminary design. Following completion of the engineering, design, and planning activities described above, the Project Team directed the Performance Partner (Mechanical Construction Contractor) and Alliance Partner (Electrical Contractor) to prepare cost estimates based on a more detailed engineering design package, that included the updated design described in the discussion of notable changes in scope above.

1. SoCalGas and SDG&E's Preliminary Mechanical Construction Contractor Estimate (confidential): SoCalGas and SDG&E's preliminary cost estimate for construction was [REDACTED].
2. Mechanical Construction Contractor's Target Price Estimate (confidential): The Mechanical Construction Contractor's cost estimate was [REDACTED], which was [REDACTED] than SoCalGas and SDG&E's preliminary cost estimate for construction.
3. SoCalGas and SDG&E's Preliminary Electrical Contractor Estimate (confidential): SoCalGas and SDG&E's preliminary cost estimate for construction was [REDACTED].
4. Electrical Contractor's Estimate (confidential): The Electrical Contractor's estimate was [REDACTED], which was [REDACTED] than SoCalGas and SDG&E's preliminary cost estimate.

Pipeline Safety Enhancement Plan Final Report
Line 5000 Banning Valve Enhancement Project Bundle

B. Construction Schedule

Table 3: Construction Timeline²

MLV 14B	
Construction Start Date	10/14/2015
Construction Completion Date	12/31/2015
Days on Site	49 days
Commissioning Date	02/19/2016
MLV 14.6B	
Construction Start Date	06/27/2016
Construction Completion Date	10/06/2016
Days on Site	32 days
Commissioning Date	04/11/2017

The Project Team completed all construction activities as soon as practicable prior to commissioning. SoCalGas and SDG&E’s finalization of commissioning activities is dependent on electrical utility connections, and system and/or resource availability.

C. Changes During Construction

SoCalGas and SDG&E successfully mitigated conditions during construction in a manner that minimized potential impacts on project scope, cost, and schedule. As a result, these conditions did not result in any notable change orders.

² Days on site will generally be less than the number of days from construction start to construction completion. This is due to factors such as scheduling of construction crews and permitting conditions.

Pipeline Safety Enhancement Plan Final Report Line 5000 Banning Valve Enhancement Project Bundle

Figure 5: MLV 14B – Solar Panel and Actuator in Foreground, New Linebreak Cabinet and Canopy in the Background



Pipeline Safety Enhancement Plan Final Report
Line 5000 Banning Valve Enhancement Project Bundle

Figure 6: MLV 14.6B – New block Wall with the New Actuator in the Background



Pipeline Safety Enhancement Plan Final Report
Line 5000 Banning Valve Enhancement Project Bundle

D. Commissioning and Site Restoration

Commissioning activities included site restoration, final inspections, and placement of the valves back into service. During this stage, SoCalGas and SDG&E successfully performed site acceptance testing and conducted point-to-point verification with SoCalGas Gas Control personnel for the newly-automated valves. SoCalGas and SDG&E trained Field Operations personnel on the proper use and operation of the new equipment. Closeout activities included development of final drawings, the reconciliation package, and updates to company recordkeeping systems to reflect the completed scope of work. The sites were commissioned on February 19, 2016 and April 11, 2017, as summarized in Table 3.

Pipeline Safety Enhancement Plan Final Report
Line 5000 Banning Valve Enhancement Project Bundle

IV. PROJECT COSTS

A. Cost Avoidance Actions

SoCalGas and SDG&E exercised due diligence in the design, planning, and construction activities for this project to minimize or avoid costs when prudent to do so. As discussed above, the Project Team reviewed existing records, communicated with external stakeholders and conducted a pre-design site walk to incorporate the known site conditions in the project plan and design. Specific examples of cost avoidance actions taken on this project were:

1. Planning and Coordination: The Project Team bundled projects to coordinate engineering and construction activity between the four project sites to reduce overall costs for customers.
2. Future Maintenance: The Project Team installed a block wall at the MLV 14.6B site to prevent future vandalism.

B. Cost Estimates

Based on the preliminary design, once the preliminary project scope was confirmed and engineering, design, and planning activities were underway, SoCalGas and SDG&E prepared an estimate of the Direct Costs of the Project in the amount of \$2,066,278. This estimate was prepared in March of 2016, using the “Stage 3 SCG Valve Estimate Template Rev 2” estimating tool, the most current version of the PSEP Estimate Template at the time.

The Project Team considered the conditions known at the time to prepare the preliminary Direct Cost estimate. This estimate reflects the projected Labor, Material and Services costs anticipated to be incurred to execute the Project, based on initial design plans.

Pipeline Safety Enhancement Plan Final Report
Line 5000 Banning Valve Enhancement Project Bundle

SoCalGas and SDG&E estimated Indirect Costs of the Project based on the estimated Direct Costs and other project-related variables.

C. Actual Direct and Indirect Costs

Actual Direct Costs reflect the Labor, Material, and Services costs incurred to execute the Project. Actual Indirect Costs reflect costs for incremental overhead loaders in accordance with Company overhead allocation policies. The total loaded cost of the Project is \$2,409,544.

Table 4: Estimated and Actual Direct Costs and Variances

Direct Costs (\$)	Estimate	Actuals	Delta Over/(Under)
Company Labor	227,989	125,941	(102,048)
Materials	187,419	161,676	(25,743)
Mechanical Construction Contractor	652,075	494,046	(158,029)
Electrical Contractor	210,652	284,267	73,615
Construction Management & Support	124,254	158,223	33,969
Environmental	82,260	111,738	29,478
Engineering & Design	256,171	439,980	183,809
Project Management & Services	77,624	73,611	(4,013)
ROW & Permits	27,024	39,695	12,671
GMA	220,810	245,368	24,558
Total Direct Costs	2,066,278	2,134,545	68,267

Pipeline Safety Enhancement Plan Final Report
Line 5000 Banning Valve Enhancement Project Bundle

Table 5: Estimated and Actual Indirect Costs, Total Costs, and Variances

Indirect Costs/Total Costs (\$)	Estimate	Actuals	Delta Over/(Under)
Overheads	307,086	207,461	(99,625)
AFUDC	205,327	58,898	(146,429)
Property Taxes	47,722	8,640	(39,082)
Total Indirect Costs	560,135	274,999	(285,136)
Total Direct Costs	2,066,278	2,134,545	68,267
Total Loaded Costs	2,626,413	2,409,544	(216,869)

Pipeline Safety Enhancement Plan Final Report
Line 5000 Banning Valve Enhancement Project Bundle

V. CONCLUSION

SoCalGas and SDG&E enhanced the safety of their integrated natural gas system by prudently executing the Banning 5000 Valve Enhancement Project Bundle. Through this Valve Enhancement Project Bundle, SoCalGas and SDG&E successfully automated two mainline valves to achieve the objective of enabling rapid system isolation in the City of Banning and Riverside County. The total loaded cost of the Project is \$2,409,544.

SoCalGas and SDG&E executed this project prudently through: designing and executing the Project to support achievement Valve Enhancement Plan isolation objectives, coordinating and bundling two valve projects into a comprehensive construction package to capture efficiencies through coordinated scheduling of construction crews, and installing equipment necessary to bring power and communication capabilities to these valves to enable rapid system isolation to a portion of Line 5000.

SoCalGas and SDG&E engaged in prudent cost avoidance efforts to complete this safety enhancement at a reasonable cost by carefully planning and coordinating construction activity, by limiting the number of mobilizations across two different project sites to maximize efficiencies and reduce customer and community impacts.

End of Line 5000 Banning Valve Enhancement Project Bundle

Pipeline Safety Enhancement Plan Final Report
El Segundo Valve Enhancement Project

I. EL SEGUNDO VALVE ENHANCEMENT PROJECT

A. Background and Summary

This report describes the activities associated with the El Segundo Valve Enhancement Project that consists of valve enhancements made to a new mainline valve (MLV) and a new crossover valve in the City of El Segundo in Los Angeles County. Through this project, SoCalGas and SDG&E enhanced the capabilities of two valves to enable rapid transmission system isolation to a portion of Line 1172. SoCalGas and SDG&E rerouted Line 1172, installed one new mainline valve, one new crossover valve, two new actuators, a new blowdown assembly, three new vaults, new crossover piping, and utility power and communications equipment at the site. The total loaded project cost is \$7,488,159.

The El Segundo Valve Enhancement Project site is east of the corner of El Segundo Boulevard and Aviation Boulevard on a heavily trafficked street in the City of El Segundo. The Project is in a high density, commercial area.

Pipeline Safety Enhancement Plan Final Report El Segundo Valve Enhancement Project

Table 1: General Project Information

El Segundo Valve Enhancement Project Bundle			
Location	City of El Segundo		
Days on Site	125 days		
Construction Start	04/27/2015		
Construction Finish	10/28/2015		
Commissioning Date	05/24/2016		
Valve Upgrades			
Valve Number	1172-0.06-0		
Valve Type	New – Ball		
Actuator	New		
Actuator Above-/Below-Grade	Below-Grade		
ASV	Yes		
RCV	Yes		
Valve Number	1172-0.07-0		
Valve Type	New – Ball		
Actuator	New		
Actuator Above-/Below-Grade	Below-Grade		
ASV	No		
RCV	Yes		
Site Upgrades			
Vault	New		
Power	New – Utility		
Communication	New – Radio		
SCADA Panel	Yes		
Equipment Shelter	None		
Wall	New – Retaining Wall		
Project Costs (\$)	Capital	O&M	Total
Loaded Project Costs	7,488,159	-	7,488,159
Disallowed Costs	-	-	-

Pipeline Safety Enhancement Plan Final Report
El Segundo Valve Enhancement Project

B. Maps and Images

Figure 1: Satellite Image of El Segundo Valve Enhancement Project



Pipeline Safety Enhancement Plan Final Report
El Segundo Valve Enhancement Project

II. ENGINEERING, DESIGN, AND PLANNING

A. Project Scope

SoCalGas and SDG&E presented a conceptual project scope in workpapers supporting the Valve Enhancement Plan¹ in the 2011 filing. This conceptual scope identified MLV 1172-0.06-0, for automation to provide remote isolation to a portion of Line 1172. Prior to initiating execution of the Project, SoCalGas and SDG&E reviewed available information and performed a detailed system flow analysis to validate the scope of the Project. This resulted in identification of a second valve for enhancement to provide the planned isolation. The final project scope is summarized in Table 2 below.

1. 2011 PSEP Filing: SoCalGas and SDG&E identified MLV 1172-0.06-0 for automation to achieve the objective of rapid system isolation.
2. Updated Scope: Upon project initiation, SoCalGas and SDG&E reviewed the conceptual project scope and determined that automation of MLV 1172-0.06-0 alone would not achieve the transmission isolation objectives set forth in the Valve Enhancement Plan. The Project Team determined it was also necessary to automate crossover valve 1172-0.07-0. Together, the automation of MLV 1172-0.06-0 and valve 1172-0.07-0 enable rapid system isolation, achieving Valve Enhancement Plan objectives.
3. Engineering, Design, and Constructability: The Project Team relocated the existing valves to the adjacent sidewalk and installed the new vaults in the sidewalk and the adjacent private property adjacent for easier future maintenance.

¹ See Workpapers supporting Amended Pipeline Safety Enhancement Plan (PSEP) of SoCalGas and SDG&E, submitted on December 2, 2011, at WP-IX-2--14 through WP-IX-2--25 (A.11-11-002 Exh. # SCG-32).

Pipeline Safety Enhancement Plan Final Report
El Segundo Valve Enhancement Project

4. **Final Project Scope:** The final project scope consists of the automation of two valves, that included the relocation of a portion of Line 1172, the installation of two new valves, the installation of two new actuators, the installation of a new blowdown assembly, the installation of three new vaults to house the actuators and the blowdown assembly, the installation of power equipment, the installation of communications equipment, and the installation of the necessary automation equipment at the project site.

Table 2: Final Project Scope

Final Project Scope					
Line	Mile	Valve #	Valve Size (<i>confidential</i>)	Installation Type	Function
1172	0.06	0	████████	NV/NP	ASV/RCV
1172	0.07	0	████████	NV/NP	RCV

B. Site Evaluation and Planning

SoCalGas and SDG&E initiated the planning process for the El Segundo Valve Enhancement Project by performing a pre-design site walk to determine existing conditions and assess any potential impacts on the design. Key factors that influenced the engineering and design of this project are as follows:

1. **Site Description:** This site is in a high-density, primarily commercial area. The existing valves were positioned on their sides and valve stems extended into a vault

Pipeline Safety Enhancement Plan Final Report
El Segundo Valve Enhancement Project

2. Land Issues:

- a. During the pre-design site walk, the Project Team noted that excavations would impact the street, sidewalk, and existing landscaping.
- b. The Project Team identified that a new permanent easement was needed for the relocated pipeline and new automation equipment.

3. DOT Class: This project site is in a Class 3 location.

4. Power Source: There was no preexisting power source, the Project Team installed new power equipment at the site.

5. Communication Technology: There was no preexisting communications equipment, the Project Team installed new communications equipment at the site.

C. Engineering, Design, and Planning Factors

SoCalGas and SDG&E reviewed drawings and records, contacted internal planning groups, communicated with external stakeholders and completed a pre-design site walk. Key factors that influenced the engineering and design of the Project are as follows:

1. Engineering Assessment:

- a. During the site evaluation, the Project Team confirmed the existing technology and measurements of the existing vault. Based on the specifications of the new actuator to be installed, the Project Team determined that the preexisting vault did not provide sufficient space to house and operate the new actuator.

Pipeline Safety Enhancement Plan Final Report
El Segundo Valve Enhancement Project

- b. The Project Team determined that a portion of the existing transmission pipeline and crossover piping with the two existing valves must be rerouted out of the middle of the street so the new valves and automation equipment would be in the sidewalk, increasing safety.

2. Valve Details:

- a. 1172-0.06-0: The preexisting valve was a manually operated Class 300 ball valve that the Project Team replaced.
- b. 1172-0.07-0: The preexisting valve was a manually operated Class 300 ball valve that the Project Team replaced.

3. Actuator Details:

- a. 1172-0.06-0: There was no preexisting actuator, the Project Team installed a new actuator.
- b. 1172-0.07-0: There was no preexisting actuator, the Project Team installed a new actuator.

4. Customer Impact:

- a. The scope of work for this project required a shut-in and relocation of Line 1172 and the replacement of the Line 1241 crossover, impacting large non-core customers including a power plant, a cogeneration plant, and a refinery. The Project Team notified these customers prior to the shut-in.
- b. The Project Team scheduled construction so that the shut-in did not occur during summer conditions.

Pipeline Safety Enhancement Plan Final Report
El Segundo Valve Enhancement Project

5. Community Impact:

- a. The Project Team worked with an affected property owner to plan the site restoration and to minimize the impact of the new installation.
- b. SoCalGas and SDG&E was performing work on a separate project in the City of El Segundo at the same time as this project. The Project Team coordinated construction schedules so the shut-in would align with the planned shut-in for that project.

6. Substructures: The Project Team identified storm drains, a water main, communication fibers, electrical utilities, and additional gas pipelines in the street. The Project Team designed the project around these existing substructures.

7. Environmental: The Project Team did not identify any environmental concerns at the site. An environmental monitor performed spot checks during construction.

8. Permit Restrictions:

- a. The Project Team received a Traffic Control Permit from The City of El Segundo for El Segundo Boulevard. The Project Team maintained the flow of traffic in both directions for the duration of construction.
- b. The City of El Segundo limited work hours from 5:00 AM to 3:00 PM, Monday through Friday, 8:00 PM to 5:00 AM Monday through Thursday and 8:00 PM to 5:00 AM Friday through Monday.

Pipeline Safety Enhancement Plan Final Report
El Segundo Valve Enhancement Project

9. Land Use:

- a. The Project Team obtained a new easement to relocate the new automation equipment into the landscaped area.
- b. The Project Team obtained a Temporary Right of Entry (TRE) laydown and staging area in the adjacent parking lot and driveway.

10. Traffic Control: The City of El Segundo restricted daytime working hours resulting in night work, and required the streets to be plated and opened for traffic during the daytime. The Project Team utilized signage and cones for Traffic Control during construction.

Pipeline Safety Enhancement Plan Final Report
El Segundo Valve Enhancement Project

Figure 2: El Segundo Valve Enhancement Project Schematic:

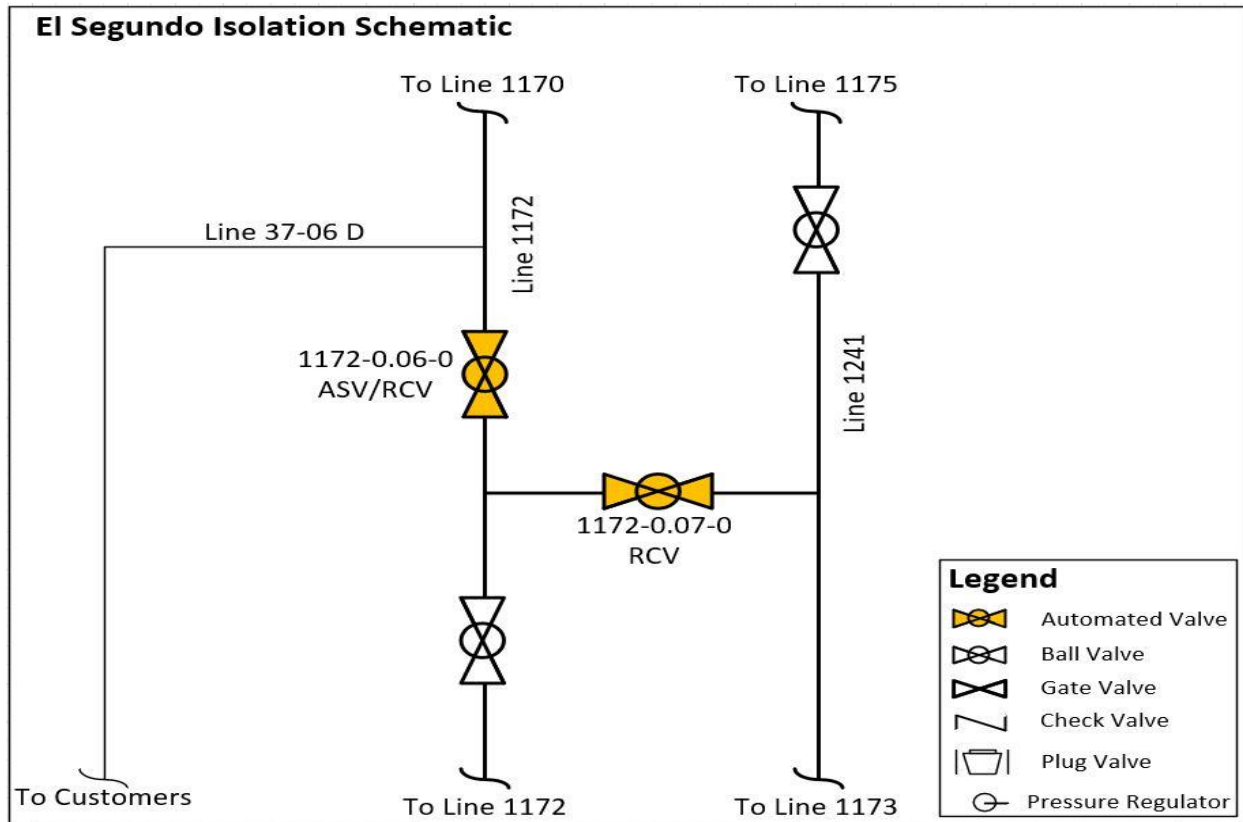

Pipeline Safety Enhancement Plan Final Report
El Segundo Valve Enhancement Project

D. Scope Changes

Through engineering, design, and planning activities, SoCalGas and SDG&E determined that changes in scope were appropriate to enhance the design of the Project and address engineering factors. As a result, the preliminary cost estimate does not fully reflect the final scope. The Project Team's initial design placed the MLV 1172-0.06-0 and the associated actuator in the sidewalk. After the creation of the preliminary estimate, the Project Team identified multiple utilities where Line 1172 was to be relocated. The Project Team redesigned the project to move the MLV out of the sidewalk.

Pipeline Safety Enhancement Plan Final Report
El Segundo Valve Enhancement Project

III. CONSTRUCTION

A. Construction Contractor Selection

The Project Team prepared an initial cost estimate based on the preliminary design. Following completion of the engineering, design, and planning activities described above, the Project Team directed the Performance Partner (Mechanical Construction Contractor) and Alliance Partner (Electrical Contractor) to prepare cost estimates based on a more detailed engineering design package, that included the updated design described in the discussion of notable changes in scope above.

1. SoCalGas and SDG&E's Preliminary Mechanical Construction Contractor Estimate (*confidential*): SoCalGas and SDG&E's preliminary cost estimate for construction was [REDACTED].
2. Mechanical Construction Contractor's Target Price Estimate (*confidential*): The Mechanical Construction Contractor's cost estimate was [REDACTED] that was [REDACTED] than SoCalGas and SDG&E's preliminary cost estimate.
3. SoCalGas and SDG&E's Preliminary Electrical Contractor Estimate (*confidential*): SoCalGas and SDG&E's preliminary cost estimate for construction was [REDACTED].
4. Electrical Contractor's Estimate (*confidential*): The Electrical Contractor's estimate was [REDACTED], that was [REDACTED] than SoCalGas and SDG&E's preliminary cost estimate.

Pipeline Safety Enhancement Plan Final Report
El Segundo Valve Enhancement Project

B. Construction Schedule

Table 3: Construction Timeline

Construction Start Date	04/27/2015
Construction Completion Date	10/28/2015
Days on Site	125 days
Commissioning Date	05/24/2016

The Project Team completed all construction activities as soon as practicable prior to commissioning. SoCalGas and SDG&E’s finalization of commissioning activities is dependent on electrical utility connections, and system and/or resource availability.

C. Changes During Construction

The conditions summarized below were encountered during construction. Activities to address or mitigate these conditions resulted in approximately \$1,140,000 in change orders.

1. Site Restoration: As part of the agreement with the land owner when providing an above-ground easement and TRE, the Project Team restored the landscaped area with drip resistant and drought tolerant landscaping.
2. Construction Method:
 - a. Potholing performed during construction determined that the existing electrical bank, where the new pipeline alignment crosses, was deeper than planned. This resulted in an increase in depth of the new pipeline to maintain the required minimum separation between the existing electrical bank and new pipeline.

Pipeline Safety Enhancement Plan Final Report El Segundo Valve Enhancement Project

- b. The Project Team planned to utilize hydraulic vertical shoring for this project. However, after potholing revealed that the existing utilities were deeper than anticipated, excavations needed to be deeper which required plate shoring.
3. Tie-In: The initial estimate assumed a 14 hour work day to complete the final tie-in at both ends for the Project. Tie-in duration was underestimated.
4. Work Hours: Following delays in obtaining permits from the City of El Segundo, SoCalGas and SDG&E directed the Construction Contractor to accelerate construction by seven days to meet the scheduled tie-in dates.
5. Safety: Following construction start, Construction Management determined that a field safety monitor would be necessary for the duration of construction, that was not originally included in the Construction Contractor's estimate.

Pipeline Safety Enhancement Plan Final Report
El Segundo Valve Enhancement Project

Figure 3: Street View of Traffic Along El Segundo Boulevard



Pipeline Safety Enhancement Plan Final Report
El Segundo Valve Enhancement Project

Figure 4: New Cabinets, Vaults, Retaining Wall, and Sidewalk



Pipeline Safety Enhancement Plan Final Report
El Segundo Valve Enhancement Project

Figure 5: Nighttime Resurfacing of El Segundo Boulevard



Pipeline Safety Enhancement Plan Final Report
El Segundo Valve Enhancement Project

D. Commissioning and Site Restoration

Commissioning activities included site restoration, final inspections, and placement of the valves into service. During this stage, SoCalGas and SDG&E successfully performed site acceptance testing and conducted point-to-point verification with SoCalGas Gas Control personnel for the newly-automated valves. SoCalGas and SDG&E trained Field Operations personnel on the proper use and operation of the new equipment. Closeout activities included development of final drawings, the reconciliation package, and updates to company recordkeeping systems to reflect the completed scope of work. The site was commissioned on May 24, 2016, as summarized in Table 3.

Pipeline Safety Enhancement Plan Final Report
El Segundo Valve Enhancement Project

IV. PROJECT COSTS

A. Cost Avoidance Actions

SoCalGas and SDG&E exercised due diligence in the design, planning, and construction activities for this project to minimize or avoid costs when prudent to do so. As discussed above, the Project Team reviewed existing records, communicated with external stakeholders, and conducted a site walk to incorporate the known site conditions in the project plan and design. When relocating the valves, the Project Team rerouted Line 1172 so that the new vaults were in the sidewalk. By locating the vaults in the sidewalk as opposed to in El Segundo Boulevard, both the time required, and the need for traffic control and delineation while performing future maintenance activities is minimized.

B. Cost Estimates

Based on the preliminary design, once the preliminary project scope was confirmed and engineering, design, and planning activities were underway, SoCalGas and SDG&E prepared an estimate of the Direct Costs of the Project in the amount of \$3,949,519. This estimate was prepared in July of 2014, using the “Stage 3 SCG Valve Estimate Template Rev 1” estimating tool, the most current version of the PSEP Estimate Template at the time. The Project Team considered the conditions known at the time to prepare the preliminary Direct Cost estimate. This estimate reflects the projected Labor, Material, and Services costs anticipated to be incurred to execute the Project, based on initial design plans.

SoCalGas and SDG&E estimated Indirect Costs of the Project based on the estimated Direct Costs and other project-related variables.

Pipeline Safety Enhancement Plan Final Report
El Segundo Valve Enhancement Project

C. Actual Direct and Indirect Costs

Actual Direct Costs reflect the Labor, Material, and Services costs incurred to execute the Project. Actual Indirect Costs reflect costs for incremental overhead loaders in accordance with Company overhead allocation policies. The total loaded cost of the Project is \$7,488,159.

Table 4: Estimated and Actual Direct Costs and Variances

Direct Costs (\$)	Estimate	Actuals	Delta Over/(Under)
Company Labor	284,957	352,243	67,286
Materials	476,985	449,784	(27,201)
Mechanical Construction Contractor	1,910,148	3,012,422	1,102,274
Electrical Contractor	220,412	63,847	(156,565)
Construction Management & Support	175,249	738,075	562,826
Environmental	107,525	131,298	23,773
Engineering & Design	218,055	721,210	503,155
Project Management & Services	59,511	200,397	140,886
ROW & Permits	67,650	168,471	100,821
GMA	429,027	767,758	338,731
Total Direct Costs	3,949,519	6,605,505	2,655,986

Table 5: Estimated and Actual Indirect Costs, Total Costs, and Variances

Indirect Costs/Total Costs (\$)	Estimate	Actuals	Delta Over/(Under)
Overheads	837,912	590,788	(247,124)
AFUDC	255,930	232,069	(23,861)
Property Taxes	53,411	59,797	6,386
Total Indirect Costs	1,147,253	882,654	(264,599)
Total Direct Costs	3,949,519	6,605,505	2,655,986
Total Loaded Costs	5,096,772	7,488,159	2,391,387

Pipeline Safety Enhancement Plan Final Report
El Segundo Valve Enhancement Project

V. CONCLUSION

SoCalGas and SDG&E enhanced the safety of their integrated natural gas system by prudently executing the El Segundo Valve Enhancement Project Bundle. Through this Valve Enhancement Project Bundle, SoCalGas and SDG&E successfully installed automation on MLV 1172-0.06-0 and crossover valve 1172-0.07-0 to achieve the objective of enabling rapid system isolation in the City of El Segundo. The total loaded cost of the Project is \$7,488,159.

SoCalGas and SDG&E executed this project prudently through: designing and executing the Project to support the achievement of Valve Enhancement Plan isolation objectives, rerouting Line 1172, by designing the Project within nearby private property to eliminate future maintenance work within the city franchise and minimizing the future impact to traffic, and installed the equipment necessary to bring power and communication capabilities to these valves to enable rapid system isolation to a portion of Line 1172 in the City of El Segundo.

SoCalGas and SDG&E engaged in prudent cost avoidance efforts to complete this safety enhancement project at a reasonable cost by carefully planning and coordinating construction activity to maximize efficiencies and reduce customer and community impacts.

End of El Segundo Valve Enhancement Project Bundle Final Report

Pipeline Safety Enhancement Plan Final Report
Haynes Station Valve Enhancement Project

I. HAYNES STATION VALVE ENHANCEMENT PROJECT

A. Background and Summary

This report describes the activities associated with the Haynes Station Valve Enhancement Project that consists of valve enhancements made to an existing mainline valve (MLV) and two crossover valves in the City of Long Beach in Los Angeles County. Through this project, SoCalGas and SDG&E enhanced the capabilities of one MLV and two crossover valves to enable rapid transmission system isolation to a portion of Line 1020. SoCalGas and SDG&E installed three new actuators, and the necessary automation equipment at the site. The total loaded project cost is \$1,750,191.

The Haynes Station Valve Enhancement Project site is an existing SoCalGas facility in the City of Long Beach next to the San Gabriel River. The site is located in an open space adjacent to residential and industrial areas. There are electrical transmission lines north of the facility.

Pipeline Safety Enhancement Plan Final Report
Haynes Station Valve Enhancement Project

Table 1: General Project Information

Haynes Station Valve Enhancement Project			
Location	City of Long Beach		
Days on Site	48 days		
Construction Start	11/14/2016		
Construction Finish	02/14/2017		
Commissioning Date	09/06/2017		
Valve Upgrades			
Valve Number	1020-6.3-0		
Valve Type	Existing – Ball		
Actuator	New		
Actuator Above-Grade/Below-Grade	Above-Grade		
ASV	Yes		
RCV	Yes		
Valve Number	1020-6.3-1		
Valve Type	Existing – Ball		
Actuator	New		
Actuator Above-Grade/Below-Grade	Above-Grade		
ASV	No		
RCV	Yes		
Valve Number	1020-6.3-2		
Valve Type	Existing – Ball		
Actuator	New		
Actuator Above-Grade/Below-Grade	Above-Grade		
ASV	No		
RCV	Yes		
Site Upgrades			
Vault	None		
Power	Existing – Utility		
Communication	Existing – Radio		
SCADA Panel	New		
Equipment Shelter	Existing		
Fencing	Expanded		
Project Costs (\$)	Capital	O&M	Total
Loaded Project Costs	1,750,191	-	1,750,191
Disallowed Costs	-	-	-

Pipeline Safety Enhancement Plan Final Report
Haynes Station Valve Enhancement Project

B. Maps and Images

Figure 1: Satellite Image of Haynes Station Valve Enhancement Project

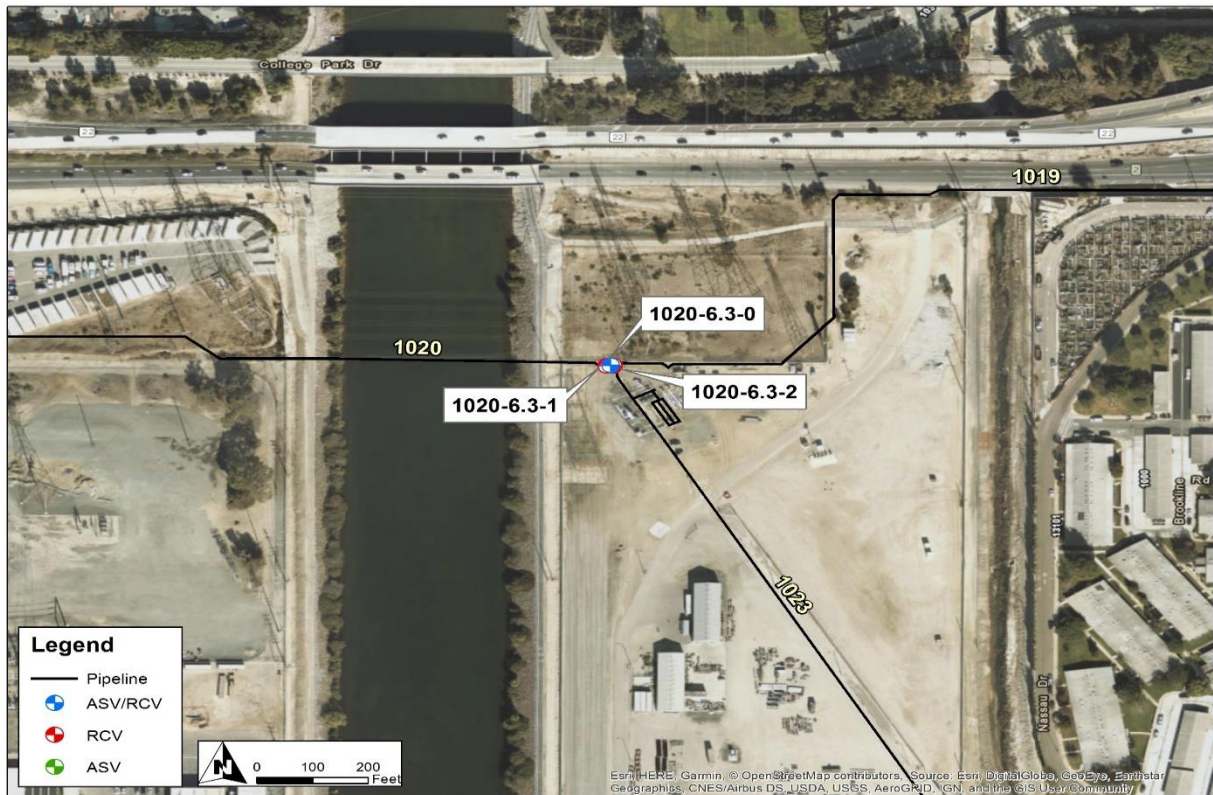

Pipeline Safety Enhancement Plan Final Report
Haynes Station Valve Enhancement Project

II. ENGINEERING, DESIGN, AND PLANNING

A. Project Scope

SoCalGas and SDG&E presented a conceptual project scope in workpapers supporting the Valve Enhancement Plan¹ in the 2011 filing. This conceptual scope identified MLV 1020-6.3-0 for automation to provide remote isolation to a portion of Line 1020. Prior to initiating execution of the Project, SoCalGas and SDG&E reviewed available information and performed a detailed system flow analysis to validate the scope of the Project. This resulted in the identification of two additional valves for enhancement to provide the planned isolation. The final project scope is summarized in Table 2 below.

1. 2011 PSEP Filing: SoCalGas and SDG&E identified MLV 1020-6.3-0 for automation to achieve the objective of rapid system isolation.
2. Updated Scope: Upon project initiation, SoCalGas and SDG&E reviewed the conceptual project scope and determined that automation of MLV 1020-6.3-0 alone would not achieve the transmission isolation objectives set forth in the Valve Enhancement Plan. The Project Team determined it was also necessary to automate two additional existing valves for isolation from Line 1023. Together, the automation of these valves enables rapid isolation, achieving Valve Enhancement Plan objectives.
3. Engineering, Design, and Constructability: No notable engineering adjustments were required.

¹ See Workpapers supporting Amended Pipeline Safety Enhancement Plan (PSEP) of SoCalGas and SDG&E, submitted on December 2, 2011, at WP-IX-2-14 through WP-IX-2-25 (A.11-11-002 Exh. # SCG-32).

Pipeline Safety Enhancement Plan Final Report
Haynes Station Valve Enhancement Project

4. **Final Project Scope:** The final project scope consisted of the automation of three valves, that included the installation of three new actuators, the expansion of an existing facility, and the installation of the necessary automation equipment at the project site.

Table 2: Final Project Scope

Final Project Scope					
Line	Mile	Valve #	Valve Size (confidential)	Installation Type	Function
1020	6.3	0	████████	A/AG	ASV/RCV
1020	6.3	1	████████	A/AG	RCV
1020	6.3	2	████████	A/AG	RCV

B. Site Evaluation and Planning

SoCalGas and SDG&E initiated the planning process for the Haynes Station Valve Enhancement Project by performing a pre-design site walk to determine the existing conditions and assess any potential impact on the design. Key factors that influenced the engineering and design of this project are as follows:

1. **Site Description:** This site is located in an existing SoCalGas facility in the City of Long Beach. A separate utility owns the property, SoCalGas and SDG&E have an easement for the facility.
2. **Land Issues:** During the pre-design site walk, the Project Team noted that the existing station would need to be expanded to accommodate the additional equipment.
3. **DOT Class:** This project site is in a Class 3 location.

Pipeline Safety Enhancement Plan Final Report
Haynes Station Valve Enhancement Project

4. Power Source: The site has existing utility power.
5. Communication Technology: The site has existing radio communications.

C. Engineering, Design, and Planning Factors

SoCalGas and SDG&E reviewed drawings and records, contacted internal planning groups, communicated with external stakeholders, conducted survey activity, and completed a pre-design site walk. Key factors that influenced the engineering and design of the Project are as follows:

1. Engineering Assessment: During the site evaluation, the Project Team confirmed the existing technology and verified the need to expand the existing station to accommodate the new equipment.
2. Valve Details:
 - a. 1020-6.3-0: The existing valve was a manually operated Class 300 ball valve that the Project Team reused.
 - b. 1020-6.3-1: The existing valve was a manually operated Class 600 ball valve that the Project Team reused.
 - c. 1020-6.3-2: The existing valve was a manually operated Class 600 ball valve that the Project Team reused.

Pipeline Safety Enhancement Plan Final Report
Haynes Station Valve Enhancement Project

3. Actuator Details:
 - a. 1020-6.3-0: There was no preexisting actuator, the Project Team installed a new actuator.
 - b. 1020-6.3-1: There was no preexisting actuator, the Project Team installed a new actuator.
 - c. 1020-6.3-2: There was no preexisting actuator, the Project Team installed a new actuator.
4. Customer Impact: The Project Team did not anticipate service disruptions to customers.
5. Community Impact: The Project Team did not anticipate any notable impacts to the community from this Project.
6. Substructures: The Project Team did not identify any existing substructures that affected the design and engineering at this site.
7. Environmental: The Project Team did not identify any notable environmental concerns at the site. An environmental monitor performed spot checks during construction.
8. Permit Restrictions: There were no special permits or permit restrictions for this project site.
9. Land Use: The Project Team expanded the existing facility to accommodate the new equipment. The Project Team obtained a new easement from the property owner.

Pipeline Safety Enhancement Plan Final Report
Haynes Station Valve Enhancement Project

10. Traffic Control: The Project Team did not identify any traffic control needs at the site.

Pipeline Safety Enhancement Plan Final Report Haynes Station Valve Enhancement Project

Figure 2: Haynes Station Valve Enhancement Project Schematic

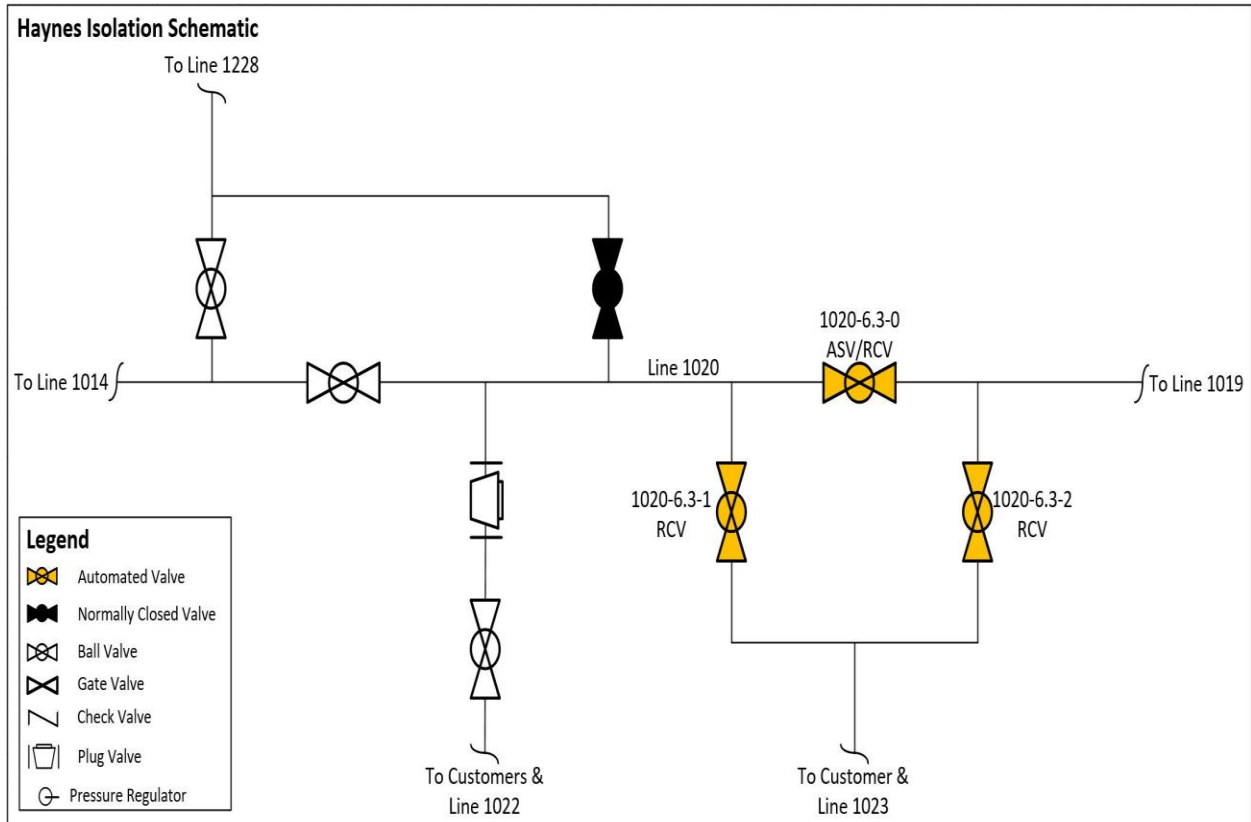

Pipeline Safety Enhancement Plan Final Report
Haynes Station Valve Enhancement Project

D. Scope Changes

SoCalGas and SDG&E did not make any notable scope changes during detailed design. The Operating District planned to install a flow meter at the Haynes station. The Electrical Contractor selected to perform the automation work added this work to their scope. PSEP did not incur any costs related to the installation of this flow meter.

Pipeline Safety Enhancement Plan Final Report
Haynes Station Valve Enhancement Project

III. CONSTRUCTION

A. Construction Contractor Selection

The Project Team prepared an initial cost estimate based on the preliminary design. Following completion of the engineering, design, and planning activities described above, the Project Team directed the Performance Partner (Mechanical Construction Contractor) and Alliance Partner (Electrical Contractor) to prepare cost estimates based on a more detailed engineering design package, that included the updated design described in the discussion of notable changes in scope above.

1. SoCalGas and SDG&E's Preliminary Mechanical Construction Contractor Estimate (*confidential*): SoCalGas and SDG&E's preliminary cost estimate for construction was [REDACTED].
2. Mechanical Construction Contractor's Target Price Estimate (*confidential*): The Mechanical Construction Contractor's cost estimate was [REDACTED], which was [REDACTED] than SoCalGas and SDG&E's preliminary cost estimate for construction.
3. SoCalGas and SDG&E's Preliminary Electrical Contractor Estimate (*confidential*): SoCalGas and SDG&E's preliminary cost estimate for construction was [REDACTED].
4. Electrical Contractor's Estimate (*confidential*): The Electrical Contractor's estimate was [REDACTED], which was [REDACTED] than SoCalGas and SDG&E's preliminary cost estimate.

Pipeline Safety Enhancement Plan Final Report
Haynes Station Valve Enhancement Project

B. Construction Schedule

Table 3: Construction Timeline

Construction Start Date	11/14/2016
Construction Completion Date	02/14/2017
Days on Site	48 days
Commissioning Date	09/06/2017

The Project Team completed all construction activities as soon as practicable prior to commissioning. SoCalGas and SDG&E’s finalization of commissioning activities is dependent on electrical utility connections, and system and/or resource availability.

C. Changes During Construction

SoCalGas and SDG&E successfully mitigated conditions during construction in a manner that minimized potential impacts on project scope, cost, and schedule. As a result, these conditions did not result in any notable change orders.

Pipeline Safety Enhancement Plan Final Report
Haynes Station Valve Enhancement Project

Figure 3: Mainline Valve Excavation and New Actuator



Pipeline Safety Enhancement Plan Final Report
Haynes Station Valve Enhancement Project

D. Commissioning and Site Restoration

Commissioning activities included site restoration, final inspections, and placement of the valves back into service. During this stage, SoCalGas and SDG&E successfully performed site acceptance testing and conducted point-to-point verification with SoCalGas Gas Control personnel for the newly-automated valves. SoCalGas and SDG&E trained Field Operations personnel on the proper use and operation of the new equipment. Closeout activities included development of final drawings, the reconciliation package, and updates to company recordkeeping systems to reflect the completed scope of work. The site was commissioned on September 6, 2017, as summarized in Table 3.

Pipeline Safety Enhancement Plan Final Report
Haynes Station Valve Enhancement Project

IV. PROJECT COSTS

A. Cost Avoidance Actions

SoCalGas and SDG&E exercised due diligence in the design, planning, and construction activities for this project to minimize or avoid costs when prudent to do so. As discussed above, the Project Team reviewed existing records, communicated with external stakeholders, and conducted a site walk to incorporate the known site conditions in the project plan and design. SoCalGas and SDG&E utilized the same construction crew for a synchronous flow meter installation project. By combining the PSEP project with the Operating District's project SoCalGas and SDG&E avoided additional mobilization and demobilization costs.

B. Cost Estimates

Based on the preliminary design, once the preliminary project scope was confirmed and engineering, design, and planning activities were underway, SoCalGas and SDG&E prepared an estimate of the Direct Costs of the Project in the amount of \$1,111,749. This estimate was prepared in October of 2014, using the "Stage 3 SCG Valve Estimate Template Rev 1" estimating tool, the most current version of the PSEP Estimate Template at the time. The Project Team considered the conditions known at the time to prepare the preliminary Direct Cost estimate. This estimate reflects the projected Labor, Material, and Services costs anticipated to be incurred to execute the Project, based on initial design plans.

SoCalGas and SDG&E estimated Indirect Costs of the Project based on the estimated Direct Costs and other project-related variables.

Pipeline Safety Enhancement Plan Final Report
Haynes Station Valve Enhancement Project

C. Actual Direct and Indirect Costs

Actual Direct Costs reflect the Labor, Material, and Services costs incurred to execute the Project. Actual Indirect Costs reflect costs for incremental overhead loaders in accordance with Company overhead allocation policies. The total loaded cost of the Project is \$1,750,191.

Table 4: Estimated and Actual Direct Costs and Variances

Direct Costs (\$)	Estimate	Actuals	Delta Over/(Under)
Company Labor	92,105	146,125	54,020
Materials	181,219	172,800	(8,419)
Mechanical Construction Contractor	276,731	279,657	2,926
Electrical Contractor	63,829	118,029	54,200
Construction Management & Support	132,144	138,613	6,469
Environmental	26,500	8,634	(17,866)
Engineering & Design	123,638	309,146	185,508
Project Management & Services	32,081	71,635	39,554
ROW & Permits	66,000	6,107	(59,893)
GMA	117,502	156,682	39,180
Total Direct Costs	1,111,749	1,407,428	295,679

Pipeline Safety Enhancement Plan Final Report
Haynes Station Valve Enhancement Project

Table 5: Estimated and Actual Indirect Costs, Total Costs, and Variances

Indirect Costs/Total Costs (\$)	Estimate	Actuals	Delta Over/(Under)
Property Taxes	148,873	213,268	64,395
AFUDC	68,616	112,816	44,200
Overheads	14,566	16,679	2,113
Total Indirect Costs	232,055	342,763	110,708
Total Direct Costs	1,111,749	1,407,428	295,679
Total Loaded Costs	1,343,804	1,750,191	406,387

Pipeline Safety Enhancement Plan Final Report
Haynes Station Valve Enhancement Project

V. CONCLUSION

SoCalGas and SDG&E enhanced the safety of their integrated natural gas system by prudently executing the Haynes Station Valve Enhancement Project. Through this Valve Enhancement Project, SoCalGas and SDG&E successfully automated one mainline valve and two crossover valves to achieve the objective of enabling rapid system isolation in the City of Long Beach. The total loaded cost of the Project is \$1,750,191.

SoCalGas and SDG&E executed this project prudently through designing and executing the Project to support achievement of Valve Enhancement Plan isolation objectives, and by installing the equipment necessary to enable rapid automated isolation to a portion of Line 1020 in the City of Long Beach.

SoCalGas and SDG&E engaged in prudent cost avoidance efforts to complete this safety enhancement work at a reasonable cost and as soon as practicable by including the installation of a flowmeter with the construction of this project, engaging in reasonable efforts to promote competitive and market-based rates for contractor services and materials, and by using a reasonable amount of company and contractor resources.

End of Haynes Station Valve Enhancement Project Final Report

Pipeline Safety Enhancement Plan Final Report
Honor Ranch Valve Enhancement Project Bundle

I. HONOR RANCH VALVE ENHANCEMENT PROJECT BUNDLE

A. Background and Summary

This report describes the activities associated with the Honor Ranch Valve Enhancement Project Bundle that consists of valve enhancements made to two existing mainline valves (MLVs) and two existing bridle valves in the City of Santa Clarita in Los Angeles County. Through this project, SoCalGas and SDG&E enhanced the capabilities of two MLVs and two bridle valves to enable rapid transmission system isolation to portions of Line 225. SoCalGas and SDG&E installed three new actuators, new power equipment at one of the sites, new communications equipment and the necessary automation equipment, at the sites. The total loaded project cost is \$1,485,602.

The four valves comprising the Honor Ranch Valve Enhancement Project Bundle are located in existing SoCalGas facilities in Los Angeles County and are separated into two different project sites. The Honor Ranch site is a fenced in facility inside the existing Honor Rancho Storage facility in an undeveloped area in the City of Santa Clarita. The Saugus site is enclosed by an existing block wall in a residential area on Magic Mountain Parkway. SoCalGas and SDG&E grouped the two project sites together into a single valve bundle and executed the two sites as a comprehensive package because the sites are geographically proximate.

Pipeline Safety Enhancement Plan Final Report
Honor Ranch Valve Enhancement Project Bundle

Table 1: General Project Information

Honor Ranch Valve Enhancement Project Bundle			
Site	Honor Ranch	Saugus	
Location	City of Santa Clarita	City of Santa Clarita	
Days on Site	88 days	9 days	
Construction Start	09/13/2016	05/16/2016	
Construction Finish	02/16/2017	06/30/2016	
Commissioning Date	06/28/2017	07/01/2016	
Valve Upgrades			
Valve Number	225-73.76-0	225-75.57-10	
Valve Type	Existing – Ball	Existing – Ball	
Actuator	New	Existing	
Actuator Above-/Below- Grade	Above-Grade	Above-Grade	
ASV	No	Yes	
RCV	Yes	Yes	
Valve Number	225-73.76-5		
Valve Type	Existing – Ball		
Actuator	New		
Actuator Above-/Below- Grade	Above-Grade		
ASV	No		
RCV	Yes		
Valve Number	225-73.76-6		
Valve Type	Existing – Ball		
Actuator	New		
Actuator Above-/Below- Grade	Above-Grade		
ASV	No		
RCV	Yes		
Site Upgrades			
Vault	None	None	
Power	New – Utility	Existing – Utility	
Communication	New – Radio	New – Radio	
SCADA Panel	New	New	
Equipment Shelter	New	New	
Fencing/Wall	Expanded – Fencing	Existing – Wall	
Project Costs (\$)	Capital	O&M	Total
Loaded Project Costs	1,485,602	-	1,485,602
Disallowed Costs	-	-	-

Pipeline Safety Enhancement Plan Final Report
Honor Ranch Valve Enhancement Project Bundle

B. Maps and Images

Figure 1: Satellite Image of Honor Ranch Valve Enhancement Project Bundle: Overview



Pipeline Safety Enhancement Plan Final Report
Honor Ranch Valve Enhancement Project Bundle

Figure 2: Honor Ranch Site



Pipeline Safety Enhancement Plan Final Report Honor Ranch Valve Enhancement Project Bundle

Figure 3: Saugus Site



Pipeline Safety Enhancement Plan Final Report
Honor Ranch Valve Enhancement Project Bundle

II. ENGINEERING, DESIGN, AND PLANNING

A. Project Scope

SoCalGas and SDG&E presented a conceptual project scope in workpapers supporting the Valve Enhancement Plan¹ in the 2011 filing. This conceptual scope identified two MLV's for automation to provide remote isolation to portions of Line 225. Prior to initiating execution of the Project, SoCalGas and SDG&E reviewed available information and performed a detailed system flow analysis to validate the scope of the Project. This resulted in the identification of one additional MLV and two bridle valves for enhancement to meet the PSEP isolation criteria. The final project scope is summarized in Table 2 below.

1. 2011 PSEP Filing: SoCalGas and SDG&E identified 225-73.76-0, 225-67.92-0 for automation to achieve the objective of rapid system isolation.
2. Updated Scope: Upon project initiation, SoCalGas and SDG&E reviewed the conceptual project scope and determined that automation of these two MLVs alone would not achieve the transmission isolation objectives set forth in the Valve Enhancement Plan. The Project Team determined it was also necessary to automate existing valves 225-73.76-5, 225-73.76-6, 225-73.76-8 and 225-73.76-9 and 225-75.57-10. Together, the automation of these seven valves enable rapid isolation, achieving Valve Enhancement Plan objectives.

¹ See Workpapers supporting Amended Pipeline Safety Enhancement Plan (PSEP) of SoCalGas and SDG&E, submitted on December 2, 2011, at WP-IX-2-14 through WP-IX-2-25 (A.11-11-002 Exh. # SCG-32).

Pipeline Safety Enhancement Plan Final Report
Honor Ranch Valve Enhancement Project Bundle

3. Engineering, Design, and Constructability:

- a. Mainline Valve 225-67.92-0 is included in the scope of a future PSEP pipeline project². The Project Team descope³ this valve from the Honor Ranch Valve Enhancement Bundle. The valve will be automated after the completion of the PSEP pipeline work³.
- b. The Project Team determined that valves 225-73.76-8 and 225-73.76-9 had existing backflow prevention measures and did not require enhancement. These valves were descope³ from the Honor Ranch Valve Enhancement Bundle.

4. Final Project Scope: The final project scope consists of the automation of four valves that included the installation of three new actuators, the installation of power equipment, the installation of communications equipment, and the installation of the necessary automation equipment at the project sites.

Table 2: Final Project Scope

Final Project Scope					
Line	Mile	Valve #	Valve Size (<i>confidential</i>)	Installation Type	Function
225	73.76	0	██████	A/AG	RCV
225	73.76	5	██████	A/AG	RCV
225	73.76	6	██████	A/AG	RCV
225	75.57	10	██████	C/P	ASV/RCV

² Line 225 (Castaic) Pipeline Replacement project was included in A.17-10-008.

³ Valve 225-67.92-0 moved to Valve L225 Honor Ranch-Castaic Project.

Pipeline Safety Enhancement Plan Final Report
Honor Ranch Valve Enhancement Project Bundle

B. Site Evaluation and Planning

SoCalGas and SDG&E initiated the planning process for the Honor Ranch Valve Enhancement Project Bundle by performing a pre-design site walk to determine existing conditions and assess any potential impacts on the design. Key factors that influenced the engineering and design of this project are as follows:

Honor Ranch

1. Site Description: This site is an existing SoCalGas facility within the larger Honor Ranch Storage facility.
2. Land Issues: During the pre-design site walk, the Project Team noted that the existing facility can accommodate the new equipment.
3. DOT Class: This project site is in a Class 1 location.
 - a. 225-73.76-0: SoCalGas and SDG&E selected this MLV for automation to isolate a Class 3 HCA location downstream of this valve.
 - b. 225-73.76-5: SoCalGas and SDG&E selected this valve for automation because it works in parallel with valves 225-73.76-0 and 225-73.76-6 and must be automated to achieve the desired isolation.
 - c. 225-73.76-6: SoCalGas and SDG&E selected this valve for automation because it works in parallel with valves 225-73.76-0 and 225-73.76-5 and must be automated to achieve the desired isolation.
4. Power Source: There was no preexisting power source, the Project Team installed new power equipment at this site.

Pipeline Safety Enhancement Plan Final Report
Honor Ranch Valve Enhancement Project Bundle

5. Communication Technology: There was no preexisting communications equipment, the Project Team installed new communications equipment at the site.

Saugus

1. Site Description: This site is an existing SoCalGas facility in a residential area. There is an existing block wall enclosing the site.
2. Land Issues: During the pre-design site walk, the Project Team noted that the existing facility can accommodate the new equipment.
3. DOT Class: This project site is in a Class 3 location.
4. Power Source: The site has existing utility power.
5. Communication Technology: There was no preexisting communications equipment, the Project Team installed new communications equipment at the site.

C. Engineering, Design, and Planning Factors

SoCalGas and SDG&E reviewed drawings and records, contacted internal planning groups, communicated with external stakeholders, conducted survey activity, and completed a pre-design site walk. Key factors that influenced the engineering and design of the Project are as follows:

Honor Ranch

1. Engineering Assessment: During the site evaluation, the Project Team confirmed the existing technology and verified that the station could accommodate the new equipment.

Pipeline Safety Enhancement Plan Final Report
Honor Ranch Valve Enhancement Project Bundle

2. Valve Details:

- a. 225-73.76-0: The existing valve was a manually actuated Class 600 ball valve that the Project Team reused.
- b. 225-73.76-5: The existing valve was a manually actuated Class 600 ball valve that the Project Team reused.
- c. 225-73.76-6: The existing valve was a manually actuated Class 600 ball valve that the Project Team reused.

3. Actuator Details:

- a. 225-73.76-0: The preexisting actuator was incompatible with PSEP linebreak technology, the Project Team installed a new actuator.
- b. 225-73.76-5: The preexisting actuator was incompatible with PSEP linebreak technology, the Project Team installed a new actuator.
- c. 225-73.76-6: The preexisting actuator was incompatible with PSEP linebreak technology, the Project Team installed a new actuator.

4. Customer Impact: The Project Team did not anticipate service disruptions to customers.

5. Community Impact: All work was performed within the existing SoCalGas Honor Ranch Storage Facility. The Project Team did not anticipate any notable impacts to the community from this project.

6. Substructures: The Project Team did not identify any existing substructures that affected the design and engineering at this site.

Pipeline Safety Enhancement Plan Final Report
Honor Ranch Valve Enhancement Project Bundle

7. Environmental: The Project Team did not identify any environmental concerns at the site. An environmental monitor performed spot checks during construction.
8. Permit Restrictions: There were no special permits or permit restrictions for this project site.
9. Land Use: The Project Team performed all work within the existing SoCalGas facility.
10. Traffic Control: The Project Team did not identify any traffic control needs at the site.

Pipeline Safety Enhancement Plan Final Report
Honor Ranch Valve Enhancement Project Bundle

Saugus

1. Engineering Assessment: During the site evaluation, the Project Team confirmed the existing technology and verified that the station could accommodate the new equipment.
2. Valve Details: The existing valve was a manually actuated Class 600 ball valve that the Project Team reused
3. Actuator Details: The existing actuator was a double-acting pneumatic actuator that the Project Team reused.
4. Customer Impact: The Project Team did not anticipate service disruptions to customers.
5. Community Impact: SoCalGas and SDG&E did not anticipate any notable impact to the community from this project.
6. Substructures: The Project Team identified no substructures during this phase that would affect the design.
7. Environmental: The Project Team did not identify any environmental concerns at the site. An environmental monitor performed spot checks during construction.
8. Permit Restrictions: There were no special permits or permit restrictions for this project site.
9. Land Use: The Project Team performed all work within the existing SoCalGas facility.
10. Traffic Control: The Project Team did not identify any traffic control needs at the site.

Pipeline Safety Enhancement Plan Final Report Honor Ranch Valve Enhancement Project Bundle

Figure 4: Honor Ranch Valve Enhancement Project Bundle Schematic

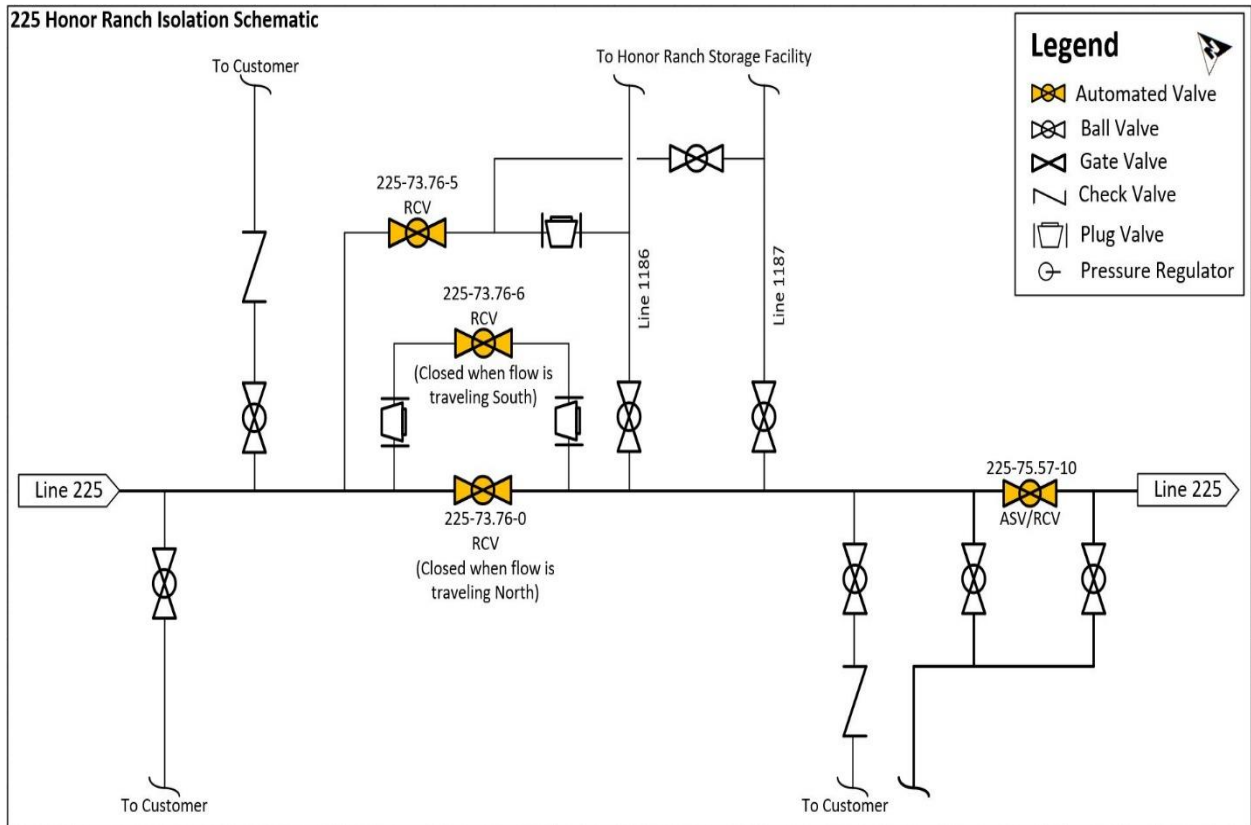

Pipeline Safety Enhancement Plan Final Report
Honor Ranch Valve Enhancement Project Bundle

D. Scope Changes

SoCalGas and SDG&E did not make any notable scope changes during detailed design.

Pipeline Safety Enhancement Plan Final Report
Honor Ranch Valve Enhancement Project Bundle

III. CONSTRUCTION

A. Construction Contractor Selection

The Project Team prepared an initial cost estimate based on the preliminary design. Following completion of the engineering, design, and planning activities described above, the Project Team directed the Performance Partner (Mechanical Construction Contractor) and Alliance Partner (Electrical Contractor) to prepare cost estimates based on a more detailed engineering design package. As indicated above, there were no notable changes in scope between the time when the Project Team prepared the preliminary cost estimate and when the Performance Partner and Alliance Partner prepared and submitted their estimates.

1. SoCalGas and SDG&E's Preliminary Mechanical Construction Contractor Estimate (*confidential*): SoCalGas and SDG&E's preliminary cost estimate for construction was [REDACTED].
2. Mechanical Construction Contractor's Target Price Estimate (*confidential*): The Mechanical Construction Contractor's cost estimate was [REDACTED], that was [REDACTED] than SoCalGas and SDG&E's preliminary cost estimate for construction.
3. SoCalGas and SDG&E's Preliminary Electrical Contractor Estimate (*confidential*): SoCalGas and SDG&E's preliminary cost estimate for construction was [REDACTED].
4. Electrical Contractor's Estimate (*confidential*): The Electrical Contractor's estimate was [REDACTED], that was [REDACTED] than SoCalGas and SDG&E's preliminary cost estimate.

Pipeline Safety Enhancement Plan Final Report
Honor Ranch Valve Enhancement Project Bundle

B. Construction Schedule

Table 3: Construction Timeline

Honor Ranch	
Construction Start Date	09/13/2016
Construction Completion Date	02/16/2017
Days on Site	88 days
Commissioning Date	06/28/2017
Saugus	
Construction Start Date	05/16/2016
Construction Completion Date	06/30/2016
Days on Site	9 days
Commissioning Date	07/01/2016

The Project Team completed all construction activities as soon as practicable prior to commissioning. SoCalGas and SDG&E’s finalization of commissioning activities is dependent on electrical utility connections, and system and/or resource availability.

C. Changes During Construction

The conditions summarized below were encountered during construction. Activities to address or mitigate these conditions resulted in approximately \$52,400 in change orders.

Pipeline Safety Enhancement Plan Final Report
Honor Ranch Valve Enhancement Project Bundle

Honor Ranch

1. Field Design Change: The Project Team initially planned to utilize an existing connection to utility power. The Project Team determined that the existing conduit would not meet the requirements of the new equipment. The Project Team decided that installing a new connection to utility power would be more cost effective than installing new conduit down a large hill from the existing storage facility. This resulted in a reconfiguration of the fence, and relocation of SCADA equipment. The Project incurred a 63day delay waiting for the installation of the new utility power connection.
2. Equipment Needs: The existing valves at the Honor Ranch site required modifications to the control valves, and valve manual operators. The internal components of the valve regulating pilot also had to be replaced.
3. Substructures: The alignment of All Plains American Pipeline interfered with the new fencing and the new SCADA equipment. The Project Team relocated the fencing and the SCADA equipment.

Saugus

The site conditions at the Saugus site had no notable impacts during construction.

Pipeline Safety Enhancement Plan Final Report
Honor Ranch Valve Enhancement Project Bundle

Figure 5: New actuator and Valve Regulating Pilots at Honor Ranch site



Pipeline Safety Enhancement Plan Final Report
Honor Ranch Valve Enhancement Project Bundle

Figure 6: New Actuators and Valve Regulating Pilots on Bridle Valves at Honor Ranch Site



Pipeline Safety Enhancement Plan Final Report
Honor Ranch Valve Enhancement Project Bundle

Figure 7: New Tubing and Three-Way Control Valve on Existing Actuator at Saugus Site



Pipeline Safety Enhancement Plan Final Report
Honor Ranch Valve Enhancement Project Bundle

D. Commissioning and Site Restoration

Commissioning activities included site restoration, final inspections, and placement of the valves back into service. During this stage, SoCalGas and SDG&E successfully performed site acceptance testing and conducted point-to-point verification with SoCalGas Gas Control personnel for the newly-automated valves. SoCalGas and SDG&E trained Field Operations personnel on the proper use and operation of the new equipment. Closeout activities included development of final drawings, the reconciliation package, and updates to company recordkeeping systems to reflect the completed scope of work. The Honor Ranch and Saugus sites were commissioned on July 1, 2016 and June 28, 2017, as summarized in Table 3.

Pipeline Safety Enhancement Plan Final Report
Honor Ranch Valve Enhancement Project Bundle

IV. PROJECT COSTS

A. Cost Avoidance Actions

SoCalGas and SDG&E exercised due diligence in the design, planning, and construction activities for this project to minimize or avoid costs when prudent to do so. As discussed above, the Project Team reviewed existing records, communicated with external stakeholders, and conducted a site walk to incorporate known site conditions in the project plan and design. Specific examples of cost avoidance actions taken on this project were:

1. Planning and Coordination: The Project Team bundled projects to coordinate engineering activities between the two Honor Ranch Valve Enhancement Project Bundle sites to reduce overall costs for customers.
2. Land Use: The Project Team utilized existing SoCalGas facilities and easements avoiding the need to acquire additional land or easements.
3. Future Maintenance: By utilizing a new utility power source, the automation equipment at the Honor Ranch site will not be affected by maintenance performed at the Honor Ranch Storage Facility.

B. Cost Estimates

Based on the preliminary design, once the preliminary project scope was confirmed and engineering, design, and planning activities were underway, SoCalGas and SDG&E prepared an estimate of the Direct Costs of the Project in the amount of \$1,609,403. These estimates were prepared in April of 2016 for the Saugus Site, and in August of 2016 for the Honor Ranch, using the “Stage 3 SCG Valve Estimate Template Rev 3” estimating tool, the most current version of the PSEP Estimate Template at the time.

Pipeline Safety Enhancement Plan Final Report
Honor Ranch Valve Enhancement Project Bundle

The Project Team considered the conditions known at the time to prepare the preliminary Direct Cost estimate. This estimate reflects the projected Labor, Material and Services costs anticipated to be incurred to execute the Project, based on initial design plans.

SoCalGas and SDG&E estimated Indirect Costs of the Project based on the estimated Direct Costs and other project related variables.

C. Actual Direct and Indirect Costs

Actual Direct Costs reflect the Labor, Material, and Services costs incurred to execute the Project. Actual Indirect Costs reflect costs for incremental overhead loaders in accordance with Company overhead allocation policies. The total loaded cost of the Project is \$1,485,602.

Table 4: Estimated and Actual Direct Costs and Variances

Direct Costs (\$)	Estimate	Actuals	Delta Over/(Under)
Company Labor	284,084	171,532	(112,552)
Materials	261,359	127,616	(133,743)
Mechanical Construction Contractor	36,300	1,533	(34,767)
Electrical Contractor	332,270	387,782	55,512
Construction Management & Support	156,251	186,249	29,998
Environmental	86,433	35,358	(51,075)
Engineering & Design	69,938	94,927	24,989
Project Management & Services	226,690	46,666	(180,024)
ROW & Permits	-	2,576	2,576
GMA	156,078	139,294	(16,784)
Total Direct Costs	1,609,403	1,193,533	(415,870)

Pipeline Safety Enhancement Plan Final Report
Honor Ranch Valve Enhancement Project Bundle

Table 5: Estimated and Actual Indirect Costs, Total Costs, and Variances

Indirect Costs/Total Costs (\$)	Estimate	Actuals	Delta Over/(Under)
Property Taxes	329,358	208,855	(120,503)
AFUDC	72,521	73,166	645
Overheads	15,180	10,048	(5,132)
Total Indirect Costs	417,059	292,069	(124,990)
Total Direct Costs	1,609,403	1,193,533	(415,870)
Total Loaded Costs	2,026,462	1,485,602	(540,860)

Pipeline Safety Enhancement Plan Final Report
Honor Ranch Valve Enhancement Project Bundle

V. CONCLUSION

SoCalGas and SDG&E enhanced the safety of their integrated natural gas system by prudently executing the Honor Ranch Valve Enhancement Project Bundle. Through this Valve Enhancement Project Bundle, SoCalGas and SDG&E successfully automated four valves to achieve the objective of enabling rapid system isolation in the City of Santa Clarita. The total loaded cost of the Project is \$1,485,602.

SoCalGas and SDG&E executed this project prudently through designing and executing the Project to support the achievement of Valve Enhancement Plan isolation objectives, coordinating and bundling two valve projects into a comprehensive construction package to capture efficiencies through coordinated scheduling of engineering work, and installing equipment necessary to bring power and communication capabilities to these valves to enable rapid automated isolation to portions of Line 225.

SoCalGas and SDG&E engaged in prudent cost avoidance efforts to complete this safety enhancement project at a reasonable cost by utilizing existing SoCalGas properties during construction avoiding the need for new land acquisitions, and by carefully planning and coordinating construction activities by limiting the number of mobilizations across two different project sites maximizing efficiencies and reducing customer and community impacts.

End of Honor Ranch Valve Enhancement Project Bundle Final Report

Pipeline Safety Enhancement Plan Final Report
Indio Valve Enhancement Project Bundle

I. INDIO VALVE ENHANCEMENT PROJECT BUNDLE

A. Background and Summary

This report describes the activities associated with the Indio Valve Enhancement Project Bundle, that consists of valve enhancements made to four existing mainline valves (MLVs) located in Riverside County. Through this project, SoCalGas and SDG&E enhanced the capabilities of four MLVs to enable rapid transmission system isolation to a portion of Lines 2000, 2001 and 2051. SoCalGas and SDG&E installed a new actuator, new fencing, new power equipment, new communications equipment, and the necessary automation equipment at the sites. The total loaded project cost is \$2,858,413.

The valves comprising the Indio Valve Enhancement Project Bundle are located in desert environments near the Cities of Indio, and Palm Springs and are separated into three project sites. SoCalGas and SDG&E grouped the three project sites together into a single valve bundle and executed the three sites as a comprehensive package because the sites are geographically proximate and are locations where work could be performed simultaneously, such that the Project Team could manage the workload between project sites and capture efficiencies by limiting the number of mobilizations and demobilizations.

Pipeline Safety Enhancement Plan Final Report Indio Valve Enhancement Project Bundle

Table 1: General Project Information

Indio Valve Enhancement Project Bundle			
Site	Valve 9	Valves 11 & 11A	Valve 11B
Location	Riverside County	Riverside County	Riverside County
Days on Site	17 days	22 days	26 days
Construction Start	07/06/2015	05/21/2015	05/20/2015
Construction Finish	09/17/2015	07/21/2015	09/17/2015
Commissioning Date	01/26/2016	01/21/2016	02/29/2016
Valve Upgrades			
Valve Number	2000-100.89-0	2000-116.15-0	2051-116.40-0
Valve Type	Existing – Ball	Existing – Ball	Existing – Ball
Actuator	Existing	Existing	New
Actuator Above-/Below-Grade	Above-Grade	Above-Grade	Above-Grade
ASV	Yes	Yes	Yes
RCV	Yes	Yes	Yes
Valve Number		2001-116.15-0	
Valve Type		Existing – Ball	
Actuator		Existing	
Actuator Above-/Below-Grade		Above-Grade	
ASV		Yes	
RCV		Yes	
Site Upgrades			
Vault	None	None	None
Power	New – Solar	New – Solar	New – Solar
Communication	New – Radio	New – Radio	New – Radio
SCADA Panel	New	New	New
Equipment Shelter	None	None	None
Fencing/Wall	Expanded – Fencing	Expanded – Fencing	New – Wall
Project Costs (\$)	Capital	O&M	Total
Loaded Project Costs	2,852,950	5,463	2,858,413
Disallowed Costs	-	-	-

Pipeline Safety Enhancement Plan Final Report
Indio Valve Enhancement Project Bundle

B. Maps and Images

Figure 1: Satellite Image of Indio Valve Enhancement Project Bundle: Overview

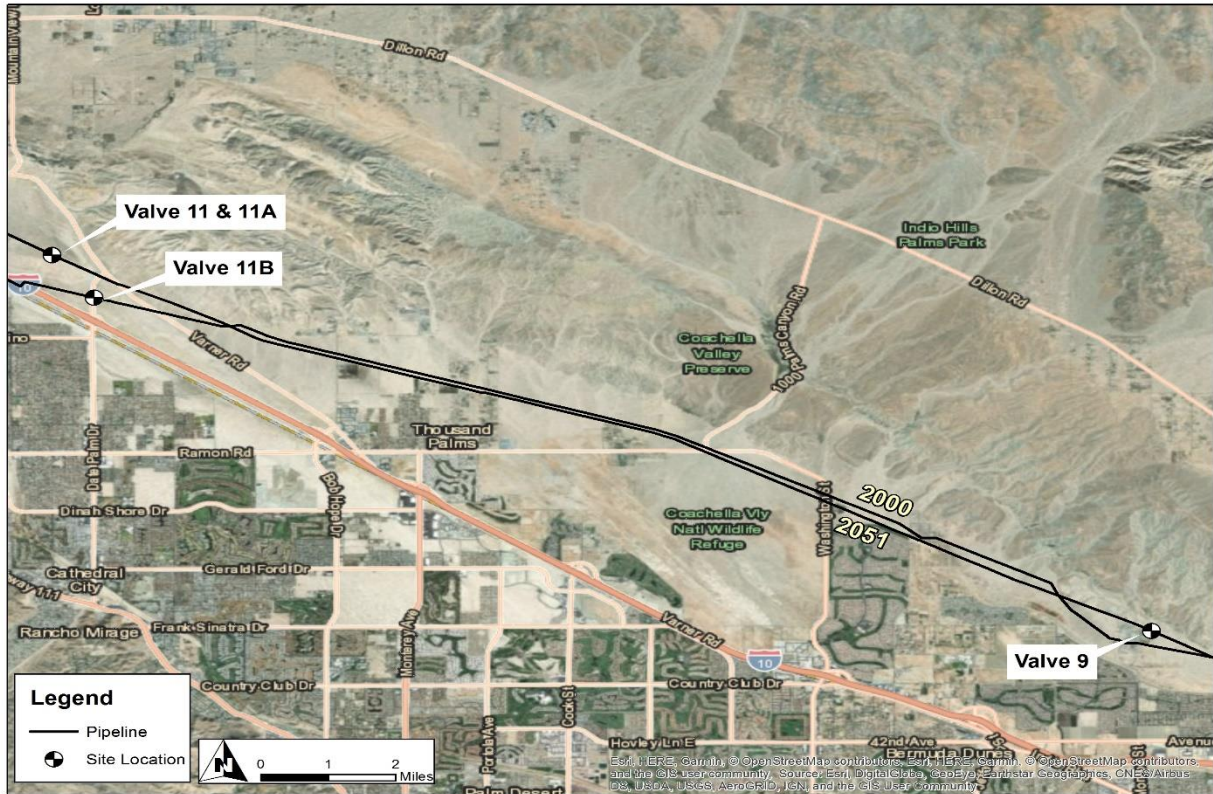

Pipeline Safety Enhancement Plan Final Report
Indio Valve Enhancement Project Bundle

Figure 2: Satellite Image of Valve 9



Pipeline Safety Enhancement Plan Final Report Indio Valve Enhancement Project Bundle

Figure 3: Satellite Image of Valves 11 and 11A

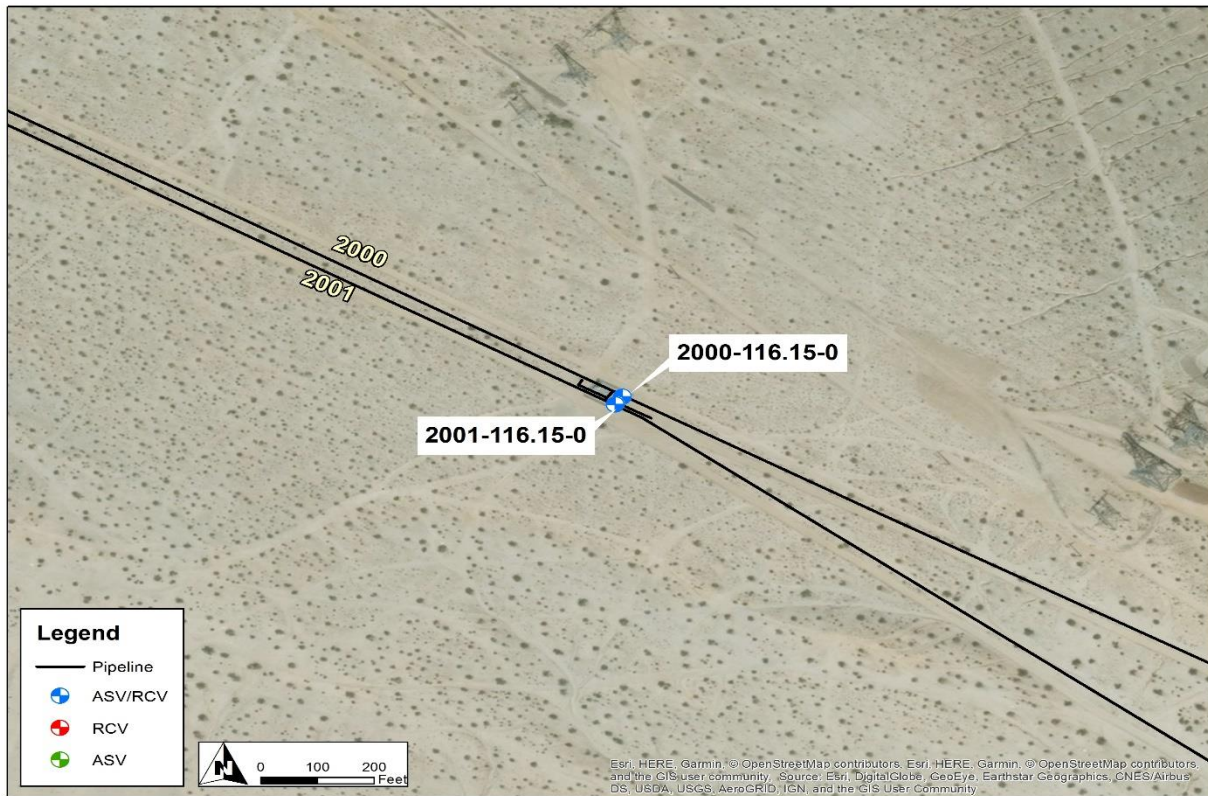

Pipeline Safety Enhancement Plan Final Report
Indio Valve Enhancement Project Bundle

Figure 4: Satellite Image of Valve 11B



Pipeline Safety Enhancement Plan Final Report
Indio Valve Enhancement Project Bundle

II. ENGINEERING, DESIGN, AND PLANNING

A. Project Scope

SoCalGas and SDG&E presented a conceptual project scope in workpapers supporting the Valve Enhancement Plan¹ in the 2011 filing. This conceptual scope identified ten valves for automation to provide remote isolation to a portion of Lines 2000, 2001, and 2051. Prior to initiating execution of the Project, SoCalGas and SDG&E reviewed available information and performed a detailed system flow analysis to validate the scope of the Project. This resulted in identification of two additional valves for enhancement to provide the planned isolation. The final project scope is summarized in Table 2 below.

1. 2011 PSEP Filing: SoCalGas and SDG&E identified ten MLVs for automation to achieve the objective of rapid system isolation.
2. Updated Scope: Upon Project initiation, SoCalGas and SDG&E reviewed the conceptual project scope and determined that automation of these valves alone would not achieve the transmission isolation objectives set forth in the Valve Enhancement Plan. SoCalGas and SDG&E determined it was also necessary to automate MLV 2000-100.89-0. Together, the automation of these valves enables rapid isolation, thereby achieving Valve Enhancement Plan objectives.

¹ See Workpapers supporting Amended Pipeline Safety Enhancement Plan (PSEP) of SoCalGas and SDG&E, submitted on December 2, 2011, at WP-IX-2-14 through WP-IX-2-25 (A.11-11-002 Exh. # SCG-32).

Pipeline Safety Enhancement Plan Final Report
Indio Valve Enhancement Project Bundle

3. Engineering, Design, and Constructability: Seven of the valves previously identified in this bundle required the acquisition of additional property rights. Due to the estimated timeframe of expanding the existing easements, these valves were descoped from this bundle and moved to a later PSEP Valve project² to be completed at a later date.
4. Final Project Scope: The final project scope consists of the automation of four valves, that included the installation of one new actuator, the expansion of the existing facilities, the installation of power equipment, the installation of communications equipment, and the installation of the necessary automation equipment at the project sites.

Table 2: Final Project Scope

Final Project Scope					
Line	Mile	Valve #	Valve Size (<i>confidential</i>)	Installation Type	Function
2000	100.89	0	████████	C/P	ASV/RCV
2000	116.15	0	████████	C/P	ASV/RCV
2001	116.15	0	████████	C/P	ASV/RCV
2051	116.40	0	████████	A/AG	ASV/RCV

² The remaining eight valves will be included in a future PSEP valve project (and will be submitted in a future filing).

Pipeline Safety Enhancement Plan Final Report
Indio Valve Enhancement Project Bundle

B. Site Evaluation and Planning

SoCalGas and SDG&E initiated the planning process for the Indio Valve Enhancement Project Bundle by performing a pre-design site walk to determine the existing conditions and assess any potential impact on the design. Key factors that influenced the engineering and design of this project are as follows:

Valve 9

1. Site Description: This site is an existing SoCalGas facility in a desert environment. There is an existing chain link fence enclosing the site.
2. Land Issues: During the pre-design site walk, the Project Team noted that the existing station would need to be expanded to accommodate the additional equipment.
3. DOT Class: This project site is in a Class 1 location. SoCalGas and SDG&E selected this MLV for automation to isolate a Class 3 HCA location downstream of this valve.
4. Power Source: The site had preexisting solar power. The Project Team installed new solar power equipment to accommodate the increased loads from the new automation equipment.
5. Communication Technology: There was no preexisting communications equipment, the Project Team installed new communications equipment at the site.

Pipeline Safety Enhancement Plan Final Report
Indio Valve Enhancement Project Bundle

Valves 11 and 11A

1. Site Description: This site is an existing SoCalGas facility in a desert environment. There is an existing chain link fence enclosing the site.
2. Land Issues: During the pre-design site walk, the Project Team noted the existing station would need to be expanded to accommodate the additional equipment.
3. DOT Class: This project site is in a Class 1 location.
 - a. MLV 2000-116.15-0: SoCalGas and SDG&E selected this MLV for automation to isolate a Class 3 HCA location upstream of this valve.
 - b. MLV 2001-116.15-0: SoCalGas and SDG&E selected this MLV for automation to isolate a Class 1 HCA location upstream of this valve, a Class 1 HCA location downstream of this valve, and a Class 3 HCA location downstream of this valve.
4. Power Source: The site had preexisting solar power. The Project Team installed new solar power equipment to accommodate the increased loads from the new automation equipment.
5. Communication Technology: There was no preexisting communications equipment, the Project Team installed new communications equipment at the site.

Valve 11B

1. Site Description: This site is an existing SoCalGas facility in a desert environment. There is an existing chain link fence enclosing the site.
2. Land Issues: During the pre-design site walk, the Project Team noted the existing station would need to be expanded to accommodate the additional equipment.

Pipeline Safety Enhancement Plan Final Report
Indio Valve Enhancement Project Bundle

3. DOT Class: This project site is in a Class 1 location. SoCalGas and SDG&E selected this MLV for automation to isolate a Class 1 HCA location downstream of this valve.
4. Power Source: There was no preexisting power source, the Project Team installed new power equipment at the site.
5. Communication Technology: There was no preexisting communications equipment, the Project Team installed new communications equipment at the site.

C. Engineering, Design, and Planning Factors

SoCalGas and SDG&E reviewed drawings and records, contacted internal planning groups, communicated with external stakeholders, conducted survey activity, and completed pre-design site walks. Key factors that influenced the engineering and design of the Project are as follows:

Valve 9

1. Engineering Assessment: During the site evaluation, the Project Team confirmed the existing technology and verified the need to expand the existing station, to accommodate the new equipment.
2. Valve Details: The existing valve was a manually actuated Class 600 ball valve that the Project Team reused.
3. Actuator Details: The existing actuator was a double-acting pneumatic actuator that the Project Team reused.
4. Customer Impact: The Project Team did not anticipate service disruptions to customers.

Pipeline Safety Enhancement Plan Final Report
Indio Valve Enhancement Project Bundle

5. Community Impact: The Project Team did not anticipate any notable impacts to the community from this project.
6. Substructures: The Project Team did not identify any existing substructures that affected the design and engineering at this site.
7. Environmental: The Project Team completed a biological survey two weeks prior to construction activities and gave approval to proceed. A biological monitor was on-site full time during construction.
8. Permit Restrictions: There were no special permits or permit restrictions for this project site.
9. Land Use: The Project Team expanded the existing easement and facility to accommodate the new automation equipment.
10. Traffic Control: The Project Team did not identify any traffic control needs at the site.

Valves 11 & 11A

1. Engineering Assessment: During the site evaluation, the Project Team confirmed the existing technology and verified the need to expand the existing station, to accommodate the new equipment.
2. Valve Details:
 - a. Valve 11: The existing valve was a manually actuated Class 600 ball valve that the Project Team reused.
 - b. Valve 11A: The existing valve was a manually actuated Class 600 ball valve that the Project Team reused.

Pipeline Safety Enhancement Plan Final Report
Indio Valve Enhancement Project Bundle

3. Actuator Details:
 - a. Valve 11: The existing actuator was a double-acting pneumatic actuator that the Project Team reused.
 - b. Valve 11A: The existing actuator was a double-acting pneumatic actuator that the Project Team reused.
4. Customer Impact: The Project Team did not anticipate service disruptions to customers.
5. Community Impact: The Project Team did not anticipate any notable impacts to the community from this project.
6. Substructures: The Project Team did not identify any existing substructures that affected the design and engineering at this site.
7. Environmental: The Project Team completed a biological survey two weeks prior to construction activities and gave the construction contractors approval to proceed. A biological monitor was on-site full time during construction.
8. Permit Restrictions: A temporary right of entry agreement was in place during construction.
9. Land Use: The Project Team expanded the existing easement and facility to accommodate the new automation equipment.
10. Traffic Control: The Project Team did not identify any traffic control needs at the site.

Pipeline Safety Enhancement Plan Final Report
Indio Valve Enhancement Project Bundle

Valve 11B

1. Engineering Assessment: During the site evaluation, the Project Team confirmed the existing technology and verified the need to expand the existing station, to accommodate the new equipment.
2. Valve Details: The existing valve was a manually actuated Class 600 ball valve that the Project Team reused.
3. Actuator Details: The preexisting actuator was incompatible with PSEP linebreak technology, the Project Team installed a new actuator.
4. Customer Impact: The Project Team did not anticipate service disruptions to customers.
5. Community Impact: The Project Team did not anticipate any notable impacts to the community from this project.
6. Substructures: The Project Team did not identify any existing substructures that affected the design and engineering at this site.
7. Environmental: SoCalGas and SDG&E completed a biological survey two weeks prior to construction activities and gave the construction contractors approval to proceed. A biological monitor was on-site full time during construction.
8. Permit Restrictions: The Project Team obtained a miscellaneous/building permit from Cathedral City for the installation of the block wall. A temporary right of entry agreement was in place during construction.

Pipeline Safety Enhancement Plan Final Report
Indio Valve Enhancement Project Bundle

9. Land Use: The Project Team expanded the existing easement and facility to accommodate the new automation equipment.
10. Traffic Control: The Project Team did not identify any traffic control needs at the site.

Pipeline Safety Enhancement Plan Final Report Indio Valve Enhancement Project Bundle

Figure 5: Indio Valve Enhancement Project Bundle Schematic

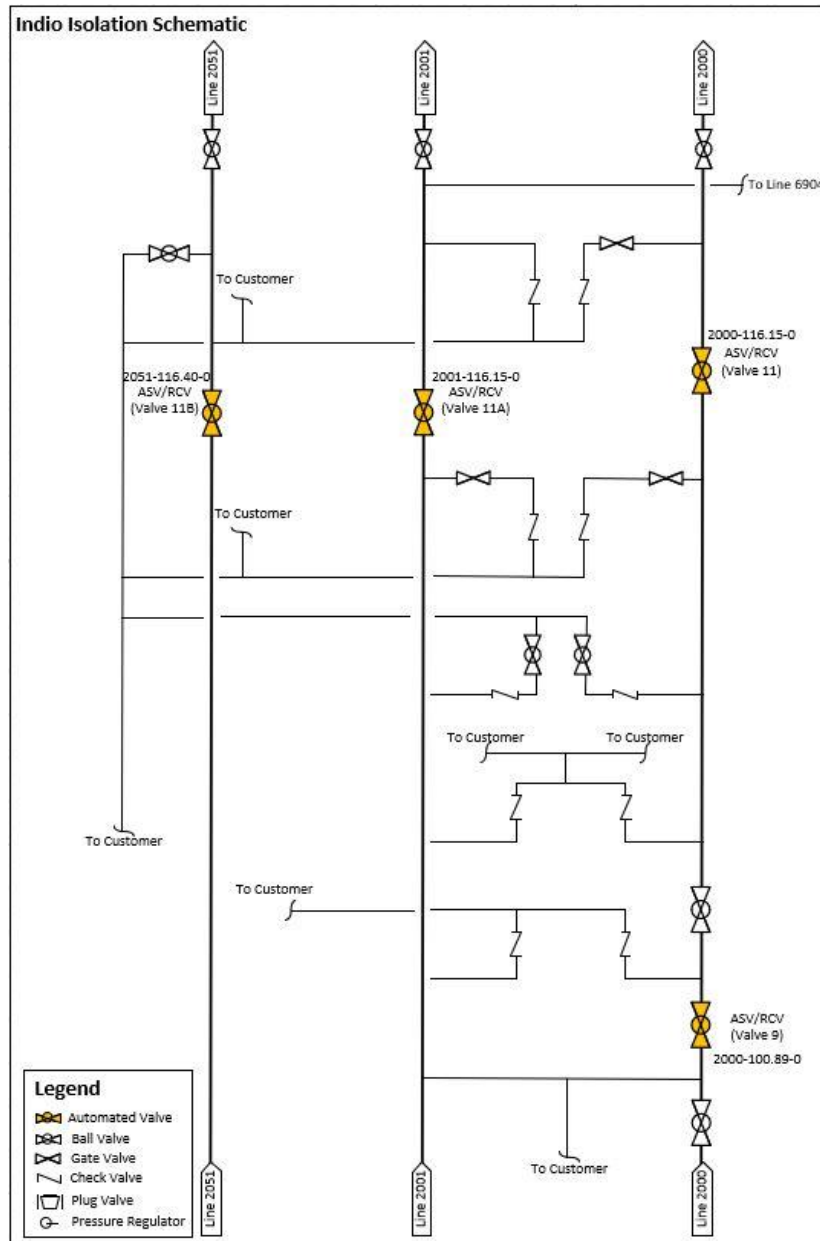

Pipeline Safety Enhancement Plan Final Report
Indio Valve Enhancement Project Bundle

D. Scope Changes

Through engineering, design, and planning activities, SoCalGas and SDG&E determined that changes in scope were appropriate to enhance the design of the Project and address engineering factors. As a result, the preliminary cost estimate does not fully reflect the final scope. Prior to construction, the Valve 11B site experienced flash flooding, that buried the existing actuator in sand. SoCalGas and SDG&E added a block wall to the scope of work to protect the existing equipment and the new equipment installed by PSEP. PSEP and the Operating District shared the cost of the block wall.

Pipeline Safety Enhancement Plan Final Report
Indio Valve Enhancement Project Bundle

III. CONSTRUCTION

A. Construction Contractor Selection

The Project Team prepared an initial cost estimate based on the preliminary design. Following completion of the engineering, design, and planning activities described above, the Project Team directed the Performance Partner (Mechanical Construction Contractor) and Alliance Partner (Electrical Contractor) to prepare cost estimates based on a more detailed engineering design package, which included the updated design described in the discussion of notable changes in scope above.

1. SoCalGas and SDG&E's Preliminary Mechanical Construction Contractor Estimate (confidential): SoCalGas and SDG&E's preliminary cost estimate for construction was [REDACTED].
2. Mechanical Construction Contractor's Target Price Estimate (confidential): The Mechanical Construction Contractor's cost estimate was [REDACTED], which was [REDACTED] than SoCalGas and SDG&E's preliminary cost estimate for construction.
3. SoCalGas and SDG&E's Preliminary Electrical Contractor Estimate (confidential): SoCalGas and SDG&E's preliminary cost estimate for construction was [REDACTED].
4. Electrical Contractor's Estimate (confidential): The Electrical Contractor's estimate was [REDACTED], which was [REDACTED] than SoCalGas and SDG&E's preliminary cost estimate.

Pipeline Safety Enhancement Plan Final Report
Indio Valve Enhancement Project Bundle

B. Construction Schedule

Table 3: Construction Timeline³

Valve 9	
Construction Start Date	07/06/2015
Construction Completion Date	09/17/2015
Days on Site	17 days
Commissioning Date	01/26/2016
Valves 11 & 11A	
Construction Start Date	05/21/2015
Construction Completion Date	07/21/2015
Days on Site	22 days
Commissioning Date	01/21/2016
Valve 11B	
Construction Start Date	05/20/2015
Construction Completion Date	09/17/2015
Days on Site	26 days
Commissioning Date	02/29/2016

The Project Team completed all construction activities as soon as practicable prior to commissioning. SoCalGas and SDG&E’s finalization of commissioning activities is dependent on electrical utility connections, and system and/or resource availability.

C. Changes During Construction

SoCalGas and SDG&E successfully mitigated conditions during construction in a manner that minimized potential impacts on project scope, cost, and schedule. As a result, these conditions did not result in any notable change orders.

³ Days on site will generally be less than the number of days from construction start to construction completion. This is due to factors such as scheduling of construction crews and permitting conditions.

Pipeline Safety Enhancement Plan Final Report
Indio Valve Enhancement Project Bundle

Figure 6: Valve 9 – Post Construction, Linebreak Cabinet in the Foreground, Shelter and Solar Array in the Background



Pipeline Safety Enhancement Plan Final Report
Indio Valve Enhancement Project Bundle

D. Commissioning and Site Restoration

Commissioning activities included site restoration, final inspections, and placement of the valves back into service. During this stage, SoCalGas and SDG&E successfully performed site acceptance testing and conducted point-to-point verification with SoCalGas Gas Control personnel for the newly-automated valves. SoCalGas and SDG&E trained Field Operations personnel on the proper use and operation of the new equipment. Closeout activities included development of final drawings, the reconciliation package, and updates to company recordkeeping systems to reflect the completed scope of work. The sites were commissioned on January 21, 2016, January 26, 2016 and February 29, 2016, as summarized in Table 3.

Pipeline Safety Enhancement Plan Final Report
Indio Valve Enhancement Project Bundle

IV. PROJECT COSTS

A. Cost Avoidance Actions

SoCalGas and SDG&E exercised due diligence in the design, planning, and construction activities for this project to minimize or avoid costs when prudent to do so. As discussed above, the Project Team reviewed existing records, communicated with external stakeholders and conducted a predesign site walk to incorporate known site conditions in the project plan and design. Specific examples of cost avoidance actions taken on this project were:

1. Planning and Coordination:
 - a. The Project Team bundled projects to coordinate engineering and construction activity between the three project sites.
 - b. The Project Team adjusted the construction schedule to allow the construction contractors to sequence construction tasks in a way that minimized crew overlap.
2. Future Maintenance: The Project Team applied anti-graffiti coating to the block wall at the Valve 11B site so that operations will not have to incur future costs to remove graffiti.

Pipeline Safety Enhancement Plan Final Report
Indio Valve Enhancement Project Bundle

B. Cost Estimates

Based on the preliminary design, once the preliminary project scope was confirmed and engineering, design, and planning activities were underway, SoCalGas and SDG&E prepared an estimate of the Direct Costs of the Project in the amount of \$1,533,223. This estimate was prepared in May of 2015, using the “Stage 3 SCG Valve Estimate Template Rev 0” estimating tool, the most current version of the PSEP Estimate Template at the time. The Project Team considered the conditions known at the time to prepare the preliminary Direct Cost estimate. This estimate reflects the projected Labor, Material, and Services Costs anticipated to be incurred to execute the Project based on initial design plans.

SoCalGas and SDG&E estimated Indirect Costs of the Project based on the estimated Direct Costs and other project-related variables.

C. Actual Direct and Indirect Costs

Actual Direct Costs reflect the Labor, Material, and Services costs incurred to execute the Project. Actual Indirect Costs reflect costs for incremental overhead loaders in accordance with Company overhead allocation policies. The total loaded cost of the Project is \$2,858,413.

Pipeline Safety Enhancement Plan Final Report
Indio Valve Enhancement Project Bundle

Table 4: Estimated and Actual Direct Costs and Variances

Direct Costs (\$)	Estimate	Actuals	Delta Over/(Under)
Company Labor	7,823	134,016	126,193
Materials	295,353	167,565	(127,788)
Mechanical Construction Contractor	147,848	326,711	178,863
Electrical Contractor	337,621	412,395	74,774
Construction Management & Support	40,593	242,391	201,798
Environmental	15,646	245,218	229,572
Engineering & Design	151,557	540,166	388,609
Project Management & Services	36,911	79,157	42,246
ROW & Permits	337,823	15,937	(321,886)
GMA	162,048	294,059	132,011
Total Direct Costs	1,533,223	2,457,615	924,392

Pipeline Safety Enhancement Plan Final Report
Indio Valve Enhancement Project Bundle

Table 5: Estimated and Actual Direct Costs, Total Costs, and Variances

Indirect Costs/Total Costs (\$)	Estimate	Actuals	Delta over/(under)
Overheads	144,859	257,137	112,278
AFUDC	53,686	127,759	74,073
Property Taxes	10,443	15,902	5,459
Total Indirect Costs	208,988	400,798	191,810
Total Direct Costs	1,533,223	2,457,615	924,392
Total Loaded Costs	1,742,211	2,858,413	1,116,202

Pipeline Safety Enhancement Plan Final Report
Indio Valve Enhancement Project Bundle

V. CONCLUSION

SoCalGas and SDG&E enhanced the safety of their integrated natural gas system by prudently executing the Indio Valve Enhancement Project Bundle. Through this Valve Enhancement Project Bundle, SoCalGas and SDG&E successfully automated four mainline valves to achieve the objective of enabling rapid system isolation in Riverside County. The total loaded cost of the Project is \$2,858,413.

SoCalGas and SDG&E executed this Project prudently through: designing and executing the Project to support achievement of Valve Enhancement Plan isolation objectives, coordinating and bundling three valve projects into a comprehensive construction package to capture efficiencies through coordinated scheduling of construction crews, expanding the existing sites to accommodate the new equipment, erecting a block wall to protect the equipment from flooding, installing the necessary automation equipment, and installing equipment necessary to bring power and communication capabilities to the valves to enable rapid system isolation to portions of Lines 2000, 2001, and 2051 in Riverside County.

SoCalGas and SDG&E engaged in prudent cost avoidance efforts to complete this safety enhancement at reasonable cost by carefully planning and coordinating construction activity, and by limiting the number of mobilizations across three different project sites to maximize efficiencies and reduce customer and community impacts.

End of Indio Valve Enhancement Project Bundle Final Report

Pipeline Safety Enhancement Plan Final Report
Lampson Valve Enhancement Project Bundle

I. LAMPSON VALVE ENHANCEMENT PROJECT BUNDLE

A. Background and Summary

This report describes the activities associated with the Lampson Valve Enhancement Project Bundle, that consists of valve enhancements made to two existing mainline valves (MLVs) and two new bridle valves in the City of Garden Grove in Orange County. Through this project, SoCalGas and SDG&E enhanced the capabilities of four valves to enable rapid transmission system isolation to a portion of Line 1019 and Supply Line 35-22. SoCalGas and SDG&E installed two new valves, four new actuators, two new vaults, new power equipment, new communications equipment, and the necessary automation equipment at the site. The total loaded project cost is \$9,632,337.

The valves comprising the Lampson Valve Enhancement Project Bundle are located in high density commercial and residential neighborhoods. The Lampson and Pine site is located east of the intersection of Lampson Avenue and Pine Street. The Topaz and Pine site is located on the west of the intersection of Lampson Avenue and Topaz Street. SoCalGas and SDG&E grouped the two project sites together into a single valve bundle and executed the two sites as a comprehensive package, because the sites are geographically proximate.

Pipeline Safety Enhancement Plan Final Report Lampson Valve Enhancement Project Bundle

Table 1: General Project Information

Lampson Valve Enhancement Project Bundle		
Site	Lampson and Pine	Lampson and Topaz
Location	Garden Grove	Garden Grove
Days on Site	66 days	49 days
Construction Start	04/27/2015	09/09/2015
Construction Finish	09/15/2016	11/18/2015
Commissioning Date	09/25/2018	08/01/2018
Valve Upgrades		
Valve Number	1019-4.93-0	1019-9.91-0
Valve Type	Existing – Ball	Existing – Ball
Actuator	New	New
Actuator Above-/Below-Grade	Below-Grade	Below-Grade
ASV	Yes	Yes
RCV	Yes	Yes
Valve Number	1019-4.93-1	
Valve Type	New – Ball	
Actuator	New	
Actuator Above-/Below-Grade	Below-Grade	
ASV	No	
RCV	Yes	
Valve Number	1019-4.93-2	
Valve Type	New – Ball	
Actuator	New	
Actuator Above-/Below-Grade	Below-Grade	
ASV	No	
RCV	Yes	
Site Upgrades		
Vault	New	New
Power	New – Utility	New – Utility
Communication	New – Radio	New – Radio
SCADA Panel	New	New
Equipment Shelter	None	None
Fencing/Wall	None	None

Pipeline Safety Enhancement Plan Final Report
Lampson Valve Enhancement Project Bundle

Table 1: General Project Information (Continued)

Project Costs (\$)	Capital	O&M	Total
Loaded Project Costs	9,632,337	-	9,632,337
Disallowed Costs	-	-	-

Pipeline Safety Enhancement Plan Final Report
Lampson Valve Enhancement Project Bundle

B. Maps and Images

Figure 1: Satellite Image of Lampson Valve Enhancement Project Bundle: Overview

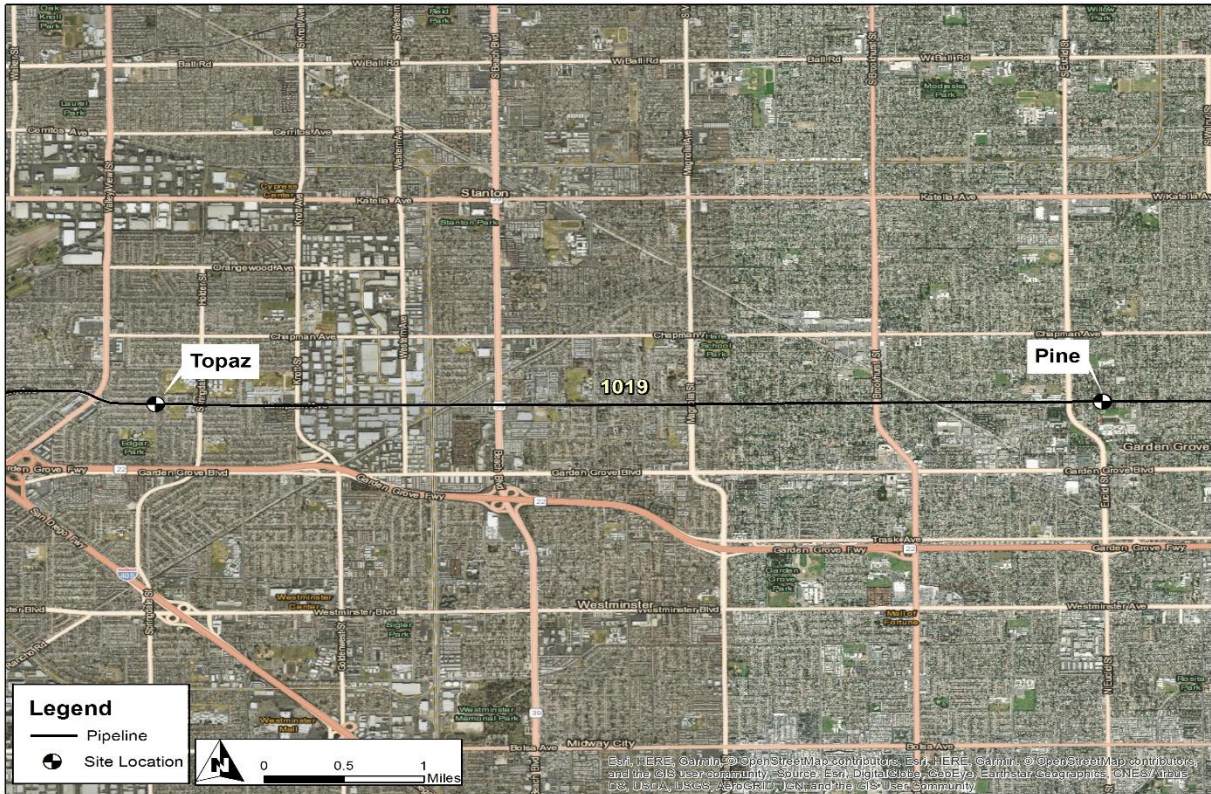

Pipeline Safety Enhancement Plan Final Report Lampson Valve Enhancement Project Bundle

Figure 2: Lampson and Pine Site



Pipeline Safety Enhancement Plan Final Report Lampson Valve Enhancement Project Bundle

Figure 3: Lampson and Topaz Site

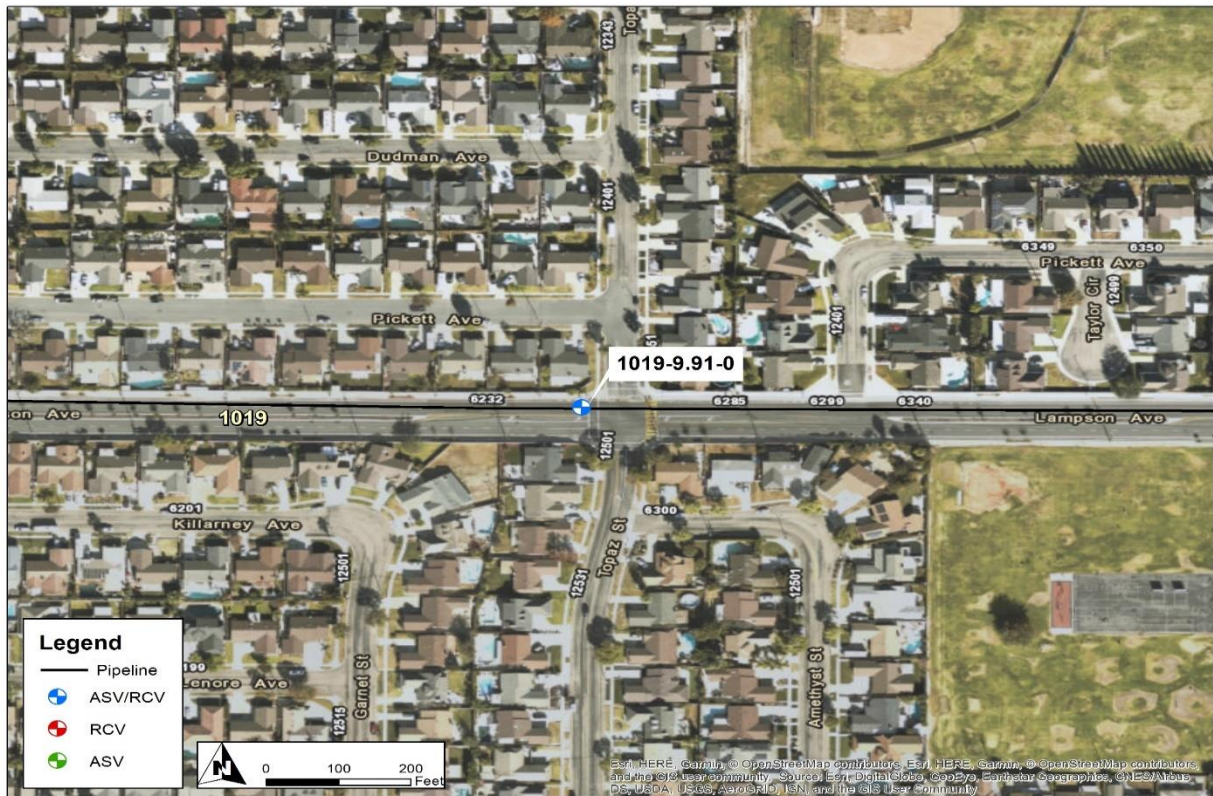

Pipeline Safety Enhancement Plan Final Report
Lampson Valve Enhancement Project Bundle

II. ENGINEERING, DESIGN, AND PLANNING

A. Project Scope

SoCalGas and SDG&E presented a conceptual project scope in workpapers supporting the Valve Enhancement Plan¹ in the 2011 filing. This conceptual scope identified two valves for automation to provide remote isolation to portions of Line 1019. Prior to initiating execution of the Project, SoCalGas and SDG&E reviewed available information and performed a detailed system flow analysis to validate the scope of the Project. This resulted in the identification of two additional valves for enhancement to provide the planned isolation. The final project scope is summarized in Table 2 below.

1. 2011 PSEP Filing: SoCalGas and SDG&E identified MLVs 1019-4.93-0 and 1019-9.91-0, for automation to achieve the objective of rapid system isolation.
2. Updated Scope: Upon project initiation, SoCalGas and SDG&E reviewed the conceptual project scope and determined that automation of the two MLVs alone would not achieve the transmission isolation objectives set forth in the Valve Enhancement Plan. The Project Team determined it was also necessary to automate two bridle valves to prevent backflow from Supply Line 35-22. Together, the automation of the two MLVs and the automation of the two bridle valves enable rapid isolation, achieving the Valve Enhancement Plan objectives.

¹ See Workpapers supporting Amended Pipeline Safety Enhancement Plan (PSEP) of SoCalGas and SDG&E, submitted on December 2, 2011, at WP-IX-2-14 through WP-IX-2-25 (A.11-11-002 Exh. # SCG-32).

Pipeline Safety Enhancement Plan Final Report
Lampson Valve Enhancement Project Bundle

3. Engineering, Design, and Constructability: The Project Team identified bridle valves 1019-4.93-1 and 1019-4.93-2, for automation to prevent backflow from Supply Line 35-22. The Project Team determined that the existing blowdown and bridle assembly required reconfiguring as the existing blowdown piping did not allow for the installation of actuators on the bridle valves.

4. Final Project Scope: The final project scope consists of the installation of two new bridle valves, the installation of four new actuators, installation of two new vaults to house the actuators, reconfiguration of a preexisting bridle assembly, the reconfiguration of a preexisting blowdown assembly, installation of power equipment, the installation of communications equipment, and the installation of the necessary automation equipment at the project sites.

Table 2: Final Project Scope

Final Project Scope					
Line	Mile	Valve #	Valve Size (<i>confidential</i>)	Installation Type	Function
1019	4.93	0	████████	A/VT	ASV/RCV
1019	4.93	1	████████	NV/VT	RCV
1019	4.93	2	████████	NV/VT	RCV
1019	9.91	0	████████	A/VT	ASV/RCV

B. Site Evaluation and Planning

SoCalGas and SDG&E initiated the planning process for the Lampson Valve Enhancement Project Bundle by performing a pre-design site walk to determine the existing conditions and assess any potential impact on the design. Key factors that influenced the engineering and design of this project are as follows:

Pipeline Safety Enhancement Plan Final Report
Lampson Valve Enhancement Project Bundle

Lampson and Pine

1. Site Description: This site is located in a high-density, residential area. The valve is located in the street and is positioned on its side. The valve stem extends into a vault. The bridle valves are in the street with the valve stems positioned in a vertical position, and the valve stems extend into valve cannisters in the street.
2. Land Issues: During the pre-design site walk, the Project Team noted that excavations will impact the street as well as the adjacent sidewalk. The Project Team utilized a space nearby as a laydown yard for both project sites.
3. DOT Class: This project site is in a Class 3 location.
4. Power Source: There was no preexisting power source, the Project Team installed new power equipment at the site.
5. Communication Technology: There was no preexisting communications equipment, the Project Team installed new communications equipment at the site.

Lampson and Topaz

1. Site Description: This site is located in a high-density, residential area. The valve is located in the street and is positioned on its side. The valve stem extends into a vault.
2. Land Issues: During the pre-design site walk, the Project Team noted that excavations will impact the street as well as the adjacent sidewalk. The Project Team utilized a space nearby as a laydown yard for both project sites.
3. DOT Class: This project site is in a Class 3 location.

Pipeline Safety Enhancement Plan Final Report
Lampson Valve Enhancement Project Bundle

4. Power Source: There was no preexisting power source, the Project Team installed new power equipment at the site.
5. Communication Technology: There was no preexisting communications equipment, the Project Team installed new communications equipment at the site.

C. Engineering, Design, and Planning Factors

SoCalGas and SDG&E reviewed drawings and records, contacted internal planning groups, communicated with external stakeholders, conducted survey activity, and completed a site walk. Key factors that influenced the engineering and design of the Project are as follows:

Lampson and Pine

1. Engineering Assessment: During the site evaluation, the Project Team confirmed the preexisting technology and measurements of the preexisting vault. Based on the specifications of the new actuator to be installed, the Project Team determined that the preexisting vault did not provide sufficient space to house and operate the new actuator. The Project Team also noted that the preexisting bridle and blowdown assembly would need to be reconfigured to allow the installation of the new actuators on bridle valves.
2. Valve Details:
 - a. 1019-4.93-0: The existing valve was a manually actuated Class 600 ball valve that the Project Team reused.
 - b. 1019-4.93-1: The preexisting valve was a manually operated Class 300 plug valve that the Project Team replaced.

Pipeline Safety Enhancement Plan Final Report
Lampson Valve Enhancement Project Bundle

- c. 1019-4.93-2: The preexisting valve was a manually operated Class 300 plug valve that the Project Team replaced.

3. Actuator Details:

- a. 1019-4.93-0: The preexisting actuator was incompatible with PSEP linebreak technology, the Project Team installed a new actuator.
- b. 1019-4.93-1: There was no preexisting actuator, the Project Team installed a new actuator.
- c. 1019-4.93-2: There was no preexisting actuator, the Project Team installed a new actuator.

4. Customer Impact: The installation of the new bridle and blowdown assembly required a shut-in of Line 1019 and Supply Line 35-22. The Project Team utilized Pressure Control Fittings (PCFs) to maintain service to Supply Line 35-22 during the shut-in. Supply Line 35-22 services a local power plant. The Project Team scheduled the tie-in so that work was completed prior to the peak summer season for the power plant, avoiding the need for CNG or LNG support.

5. Community Impact: The Project Team restricted public access to the sidewalk during construction.

6. Substructures: The Project Team analyzed the preexisting vault to design the new vault to utilize existing taps. Aside from the preexisting vault and piping, the Project Team identified no substructures during this phase that would affect the design.

7. Environmental: The Project Team did not identify any notable environmental concerns at the site. An environmental monitor performed spot checks during construction.

Pipeline Safety Enhancement Plan Final Report
Lampson Valve Enhancement Project Bundle

8. Permit Restrictions: The Project Team obtained an Encroachment Permit from the City of Garden Grove for construction. The Project Team also obtained a permit from the City of Garden Grove for the planned street work.
9. Land Use: The Project Team utilized a nearby laydown area for both project sites.
10. Traffic Control: The Project Team closed one traffic lane during construction for excavation. The Project Team plated the excavation during non-working hours to allow traffic to pass through unimpeded during non-construction hours.

Lampson and Topaz

1. Engineering Assessment: During the site evaluation, the Project Team confirmed the preexisting technology and measurements of the preexisting vault. Based on the specifications of the new actuator to be installed, the Project Team determined that the preexisting vault did not provide sufficient space to house and operate the new actuator.
2. Valve Details: The existing valve was a manually actuated Class 300 ball valve that the Project Team reused.
3. Actuator Details: The preexisting actuator was incompatible with PSEP linebreak technology, the Project Team installed a new actuator.
4. Customer Impact: The Project Team did not anticipate service disruptions to customers.
5. Community Impact: The Project Team restricted public access to the sidewalk during construction.

Pipeline Safety Enhancement Plan Final Report Lampson Valve Enhancement Project Bundle

6. Substructures: The Project Team analyzed the preexisting vault to design the new vault to utilize existing taps. Aside from the preexisting vault, the Project Team identified no substructures during this phase that would affect the design.
7. Environmental: The Project Team did not identify any notable environmental concerns at the site. An environmental monitor performed spot checks during construction.
8. Permit Restrictions: The Project Team obtained an Encroachment Permit from the City of Garden Grove for construction. The Project Team also obtained a permit from the City of Garden Grove for the planned street work.
9. Land Use: The Project Team utilized a nearby laydown area for both project sites.
10. Traffic Control: The Project Team closed one traffic lane during construction for excavation. The Project Team plated the excavation during non-working hours to allow traffic to pass through unimpeded during non-construction hours.

Pipeline Safety Enhancement Plan Final Report Lampson Valve Enhancement Project Bundle

Figure 4: Lampson Valve Enhancement Project Bundle Schematic

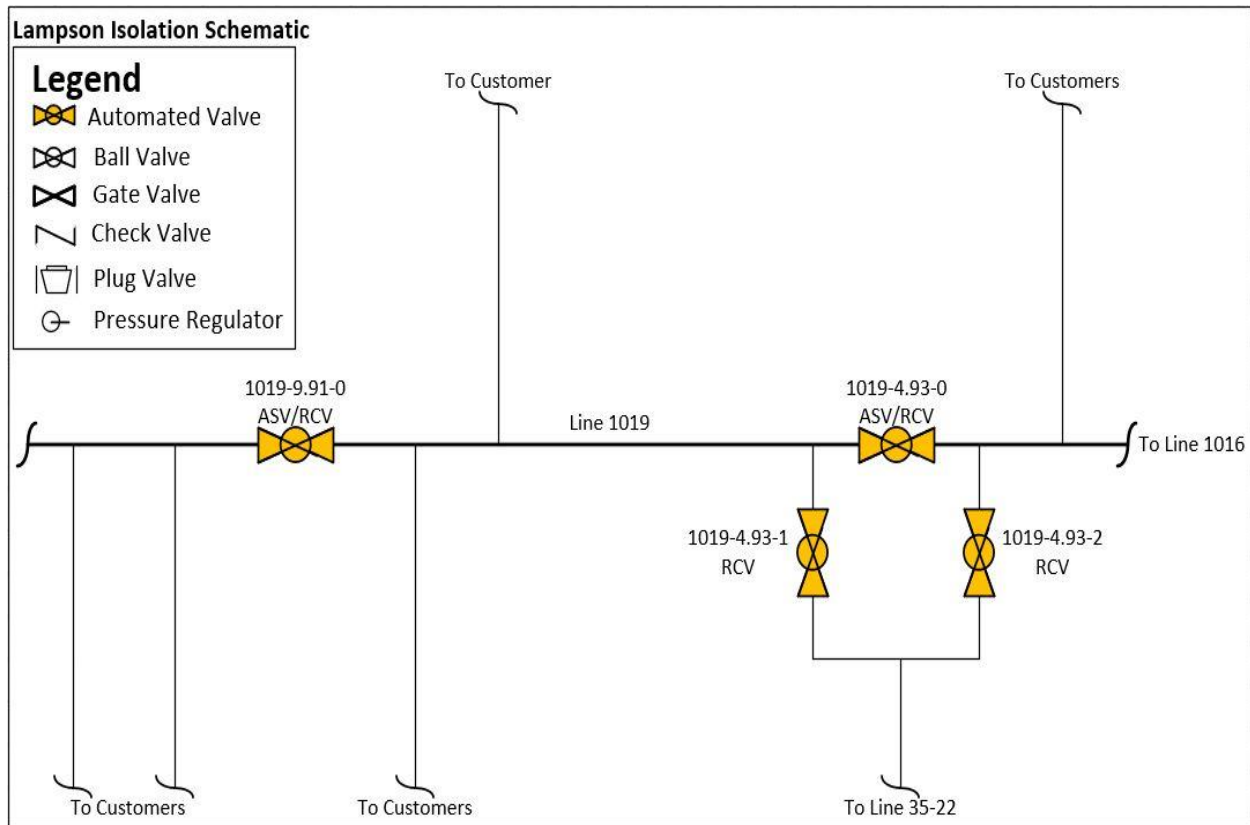

Pipeline Safety Enhancement Plan Final Report
Lampson Valve Enhancement Project Bundle

D. Scope Changes

SoCalGas and SDG&E did not make any notable scope changes during detailed design.

Pipeline Safety Enhancement Plan Final Report
Lampson Valve Enhancement Project Bundle

III. CONSTRUCTION

A. Construction Contractor Selection

The Project Team prepared an initial cost estimate based on the preliminary design. Following completion of the engineering, design, and planning activities described above, the Project Team directed the Performance Partner (Mechanical Construction Contractor) and Alliance Partner (Electrical Contractor) to prepare cost estimates based on a more detailed engineering design package. As indicated above, there were no notable changes in scope between the time when the Project Team prepared the preliminary cost estimate and when the Performance Partner and Alliance Partner prepared and submitted their estimates.

1. SoCalGas and SDG&E's Preliminary Mechanical Construction Contractor Estimate (*confidential*): SoCalGas and SDG&E's preliminary cost estimate for construction was [REDACTED].
2. Mechanical Construction Contractor's Target Price Estimate (*confidential*): The Mechanical Construction Contractor's cost estimate was [REDACTED], which was [REDACTED] than SoCalGas and SDG&E's preliminary cost estimate for construction.
3. SoCalGas and SDG&E's Preliminary Electrical Contractor Estimate (*confidential*): SoCalGas and SDG&E's preliminary cost estimate for construction was [REDACTED].
4. Electrical Contractor's Estimate (*confidential*): The Electrical Contractor's estimate was [REDACTED], which was [REDACTED] than SoCalGas and SDG&E's preliminary cost estimate.

Pipeline Safety Enhancement Plan Final Report
Lampson Valve Enhancement Project Bundle

B. Construction Schedule

Table 3: Construction Timeline

Lampson and Pine	
Construction Start Date	04/27/2015
Construction Completion Date	09/15/2016
Days on Site	66 days
Commissioning Date	09/25/2018
Lampson and Topaz	
Construction Start Date	09/09/2015
Construction Completion Date	11/18/2015
Days on Site	49 days
Commissioning Date	08/01/2018

The Project Team completed all construction activities as soon as practicable prior to commissioning. SoCalGas and SDG&E’s finalization of commissioning activities is dependent on electrical utility connections, and system and/or resource availability.

C. Changes During Construction

The conditions summarized below were encountered during construction. Activities to address or mitigate these conditions resulted in approximately \$1,071,000 in change orders.

Lampson and Pine

1. Schedule Delay: Construction completion was delayed due a combination of the reasons listed below. The Mechanical Construction Contractor incurred additional costs for fencing, shoring, traffic control, portable restrooms, and additional equipment due to these delays.

Pipeline Safety Enhancement Plan Final Report
Lampson Valve Enhancement Project Bundle

2. Design Change: The new vault required modifications after installation. The ladder had to be relocated. Additionally, the planned vault installation interfered with existing, below-grade utilities. A temporary lid was fabricated and installed. The Mechanical Construction Contractor returned at a later date to install a permanent lid.
3. Tie-in:
 - a. The Project Team scheduled the tie-in to be performed during non-peak hours for the local power plant serviced by Supply Line 35-22 that required weekend work. The shut-in was spread out over five separate tie-ins. The first, second, and third tie-in extended beyond the planned time due to complicated gas handling procedures.
 - b. The Mechanical Construction Contractor worked overtime to meet the scheduled tie-in dates.
4. Laydown Yard: The Project Team utilized property owned by the local electric utility as a laydown yard. Construction activities extended beyond the planned duration with the local electric utility and they were unable to extend the length of the agreement. The Project Team requested that the Mechanical Construction Contractor move the laydown yard from Lakewood to a new location in Garden Grove.
5. Extended Scope: The City of Garden Grove requested that SoCalGas and SDG&E perform work on sink holes created at the construction site. The Project Team requested the Mechanical Construction Contractor to perform this work.
6. Constructability Issues: The demolition of the preexisting vault took three days longer than scheduled.

Pipeline Safety Enhancement Plan Final Report
Lampson Valve Enhancement Project Bundle

7. Traffic Control Plan:

- a. The Mechanical Construction Contractor's TPE was based on a preliminary version of the Traffic Control Plan. Prior to construction, the Project Team revised the traffic control plans to include k-rails, changeable message signs, temporary striping, and additional signage, increasing the level of safety for the construction crews and the general public.
- b. The Mechanical Construction Contractor's TPE was based on a preliminary version of the Traffic Control Plan. During the permitting process, the Project Team received a request from Los Angeles County to update the Traffic Control Plan to include additional traffic controls during the holiday weekend that included two additional traffic controllers.

8. Customer Impact Mitigation: During the fifth tie-in, SoCalGas Gas Control was unable to interrupt the gas supply and rescheduled the fifth tie-in due to customer demand during the planned tie-in.

9. Field Design Change: The Project Team requested that the Mechanical Construction Contractor assist with the installation of the body bleed lines and the grease lines for the valve. The Mechanical Construction Contractor also assisted with the installation of the instrument piping.

Lampson and Topaz

1. Site Conditions: The Mechanical Construction Contractor encountered groundwater at the site that resulted in delays in construction and additional costs.

Pipeline Safety Enhancement Plan Final Report
Lampson Valve Enhancement Project Bundle

2. Schedule Delay: Upon completion of the vault installation for the new blowdown assembly, the City of Garden Grove requested that the top of the blowdown vault be redesigned. This resulted in additional overhead costs incurred by the Mechanical Construction Contractor due to the extended construction schedule.
3. Substructure: The Mechanical Construction Contractor had to demolish more of the existing vault than initially planned and also had to extend the excavations and shoring in order to replace the existing body bleed valves on the bottom of the MLV.
4. Construction Method: The Mechanical Construction Contractor had to demolish a portion of a nearby block wall in order to mitigate the groundwater encountered during excavations. The Mechanical Construction Contractor had to repair the block wall and restore the existing vegetation.
5. Traffic Control: The City of Garden Grove required that two changeable message boards be set up prior to construction and remain during all lane closures.
6. Site Restoration: The Project Team requested that the sidewalk and curb be replaced.
7. Extended Scope: The Project Team requested that the Mechanical Construction Contractor assist the Electrical Contractor with all excavations and backfill.

Pipeline Safety Enhancement Plan Final Report Lampson Valve Enhancement Project Bundle

Figure 5: Lampson and Pine – New Vault and Actuators



Pipeline Safety Enhancement Plan Final Report Lampson Valve Enhancement Project Bundle

Figure 6: Lampson and Topaz – New Electrical Trench Prior to Backfill



Pipeline Safety Enhancement Plan Final Report
Lampson Valve Enhancement Project Bundle

D. Commissioning and Site Restoration

Commissioning activities included site restoration, final inspections, and placement of the valves back into service. During this stage, SoCalGas and SDG&E successfully performed site acceptance testing and conducted point-to-point verification with SoCalGas Gas Control personnel for the newly-automated valves. SoCalGas and SDG&E trained Field Operations personnel on the proper use and operation of the new equipment. Closeout activities included development of final drawings, the reconciliation package, and updates to company recordkeeping systems to reflect the completed scope of work. The sites were commissioned on August 1, 2018 and October 25, 2018, as summarized in Table 3.

Pipeline Safety Enhancement Plan Final Report
Lampson Valve Enhancement Project Bundle

IV. PROJECT COSTS

A. Cost Avoidance Actions

SoCalGas and SDG&E exercised due diligence in the design, planning, and construction activities for this project to minimize or avoid costs when prudent to do so. As discussed above, the Project Team reviewed existing records, communicated with external stakeholders, and conducted a site walk to incorporate the known site conditions in the project plan and design. Specific examples of cost avoidance actions taken on this project were:

1. Planning and Coordination:

- a. The Project Team bundled projects to coordinate engineering and construction activity between the three project sites.
- b. The Project Team scheduled construction so that the shut-in aligned with the customers' demand schedule thus avoiding the need for CNG or LNG.

B. Cost Estimates

Based on the preliminary design, once the preliminary project scope was confirmed and engineering, design, and planning activities were underway, SoCalGas and SDG&E prepared an estimate of the Direct Costs of the Project in the amount of \$3,774,363. This estimate was prepared in June of 2013, using the "Stage 3 SCG Valve Estimate Template Rev 0" estimating tool, the most current version of the PSEP Estimate Template at the time. The Project Team considered the conditions known at the time to prepare the preliminary Direct Cost estimate. This estimate reflects the projected Labor, Material, and Services costs anticipated to be incurred to execute the Project, based on initial design plans.

Pipeline Safety Enhancement Plan Final Report
Lampson Valve Enhancement Project Bundle

SoCalGas and SDGE estimated Indirect Costs of the Project based on the estimated Direct Costs and other project-related variables.

C. Actual Direct and Indirect Costs

Actual Direct Costs reflect the Labor, Material, and Services costs incurred to execute the Project. Actual Indirect Costs reflect costs for incremental overhead loaders in accordance with Company overhead allocation policies. The total loaded cost of the Project is \$9,632,337.

Table 4: Estimated and Actual Direct Costs and Variances

Direct Costs (\$)	Estimate	Actuals	Delta Over/(Under)
Company Labor	290,623	456,753	166,130
Materials	558,795	514,773	(44,022)
Mechanical Construction Contractor	1,536,951	2,742,604	1,205,653
Electrical Contractor	256,080	202,802	(53,278)
Construction Management & Support	164,122	979,060	814,938
Environmental	38,720	277,348	238,628
Engineering & Design	396,386	1,653,396	1,257,010
Project Management & Services	122,220	222,623	100,403
ROW & Permits	11,550	63,337	51,787
GMA	398,916	929,854	530,938
Total Direct Costs	3,774,363	8,042,550	4,268,187

Pipeline Safety Enhancement Plan Final Report
Lampson Valve Enhancement Project Bundle

Table 5: Estimated and Actual Indirect Costs, Total Costs, and Variances

Indirect Costs/Total Costs (\$)	Estimate	Actuals	Delta Over/(Under)
Overheads	610,636	718,575	107,939
AFUDC	152,443	770,460	618,017
Property Taxes	30,115	100,752	70,637
Total Indirect Costs	793,194	1,589,787	796,593
Total Direct Costs	3,774,363	8,042,550	4,268,187
Total Loaded Costs	4,567,557	9,632,337	5,064,780

Pipeline Safety Enhancement Plan Final Report
Lampson Valve Enhancement Project Bundle

V. CONCLUSION

SoCalGas and SDG&E enhanced the safety of their integrated natural gas system by prudently executing the Lampson Valve Enhancement Project Bundle. Through this Valve Enhancement Project Bundle, SoCalGas and SDG&E successfully automated four valves to achieve the objective of enabling rapid system isolation in the City of Garden Grove. The total loaded cost of the Project is \$9,632,337.

SoCalGas and SDG&E executed this project prudently through designing and executing the Project to support achievement of Valve Enhancement Plan isolation objectives; installing two new vaults, and installing equipment necessary to bring power and communication capabilities to this valve to enable rapid system isolation to a portion of Line 1019 and Supply Line 35-22.

SoCalGas and SDG&E engaged in prudent cost avoidance efforts to complete this safety enhancement work at a reasonable cost by carefully planning and coordinating engineering and construction activities between the two projects, limiting the number of mobilizations and reducing costs for customers.

End of Lampson Valve Enhancement Project Bundle Final Report

Pipeline Safety Enhancement Plan Final Report
Line 1005 Santa Barbara Valve Enhancement Project**I. LINE 1005 SANTA BARBARA VALVE ENHANCEMENT PROJECT**

A. Background and Summary

This report describes the activities associated with the Line 1005 Santa Barbara Valve Enhancement Project, that consists of valve enhancements made to an existing mainline valve (MLV) in Toro Canyon in Santa Barbara County. Through this project, SoCalGas and SDG&E enhanced the capabilities of one MLV to enable rapid transmission system isolation to a portion of Line 1005. SoCalGas and SDG&E installed a new actuator, new fencing, new power equipment, new communications equipment, and the necessary automation equipment at the site. The total loaded project cost is \$516,400.

The Santa Barbara Line 1005 Valve Enhancement Project site is located next to several orchid greenhouses in Toro Canyon in Santa Barbara County.

Pipeline Safety Enhancement Plan Final Report
Line 1005 Santa Barbara Valve Enhancement Project

Table 1: General Project Information

Line 1005 Santa Barbara Valve Enhancement Project			
Location	Toro Canyon		
Days on Site	18 days		
Construction Start	03/02/2015		
Construction Finish	04/23/2015		
Commissioning Date	03/10/2016		
Valve Upgrades			
Valve Number	1005-18.39-0		
Valve Type	Existing – Ball		
Actuator	New		
Actuator Above-/Below-Grade	Above-Grade		
ASV	Yes		
RCV	Yes		
Site Upgrades			
Vault	None		
Power	New – Utility		
Communication	New – Radio		
SCADA Panel	New		
Equipment Shelter	None		
Fencing/Wall	None		
Project Costs (\$)	Capital	O&M	Total
Loaded Project Costs	516,400	-	516,400
Disallowed Costs	-	-	-

Pipeline Safety Enhancement Plan Final Report
Line 1005 Santa Barbara Valve Enhancement Project

B. Maps and Images

Figure 1: Satellite Image of Line 1005 Santa Barbara Valve Enhancement Project



Pipeline Safety Enhancement Plan Final Report
Line 1005 Santa Barbara Valve Enhancement Project

II. ENGINEERING, DESIGN, AND PLANNING

A. Project Scope

SoCalGas and SDG&E presented a conceptual project scope in workpapers supporting the Valve Enhancement Plan¹ in the 2011 filing. This conceptual scope identified MLV 1005-18.04-0 for automation, to provide remote isolation to a portion of Line 1005. Prior to initiating execution of the Project, SoCalGas and SDG&E reviewed available information and performed a detailed system flow analysis to validate the scope of the Project that confirmed that this enhancement will provide the planned isolation. The final project scope is summarized in Table 2 below.

1. 2011 PSEP Filing: SoCalGas and SDG&E identified MLV 1005-18.04-0 for automation to achieve the objective of rapid system isolation.
2. Updated Scope: Upon project initiation, SoCalGas and SDG&E reviewed the conceptual project scope and determined that this isolation point would enable rapid isolation, thereby achieving Valve Enhancement Plan objectives.
3. Engineering, Design, and Constructability: As part of the PSEP Line 1005 Replacement Project², SoCalGas and SDG&E replaced and relocated the existing MLV 1005-18.04, relocating the valve within a new fenced valve station at Mile Point (MP) 18.39. The scope of this PSEP Valve Enhancement Project was modified to exclude installation of a new MLV and included the installation of a new actuator, the installation of utility power, and the installation of communications at this valve site.

¹ See Workpapers supporting Amended Pipeline Safety Enhancement Plan (PSEP) of SoCalGas and SDG&E, submitted on December 2, 2011, at WP-IX-2-14 through WP-IX-2-25 (A.11-11-002 Ex. SCG-32).

² The final report for Line 1005 Replacement Project was submitted in workpapers supporting A.16-09-005, WP-III-A2 and includes a description of the activities and costs associated with the installation of MLV 1005-18.90.0.

Pipeline Safety Enhancement Plan Final Report
Line 1005 Santa Barbara Valve Enhancement Project

After the preliminary estimate was developed, the Project Team determined that four-wire communication would not be available. The Project Team altered the design to incorporate radio communications.

4. Final Project Scope: The final project scope consists of the automation of one valve that included the installation of a new actuator, the installation of power equipment, the installation of communications equipment, and the installation of necessary automation equipment at the project site.

Table 2: Final Project Scope

Final Project Scope					
Line	Mile	Valve #	Valve Size (confidential)	Installation Type	Function
1005	18.39	0		A/AG	ASV/RCV

B. Site Evaluation and Planning

SoCalGas and SDG&E initiated the planning process for the Santa Barbara Line 1005 Valve Enhancement Project by performing a pre-design site walk to determine the existing conditions and assess any potential impact on the design. Key factors that influenced the engineering and design of this project are as follows:

1. Site Description: This site is in Santa Barbara County, next to several greenhouses. SoCalGas and SDG&E recently installed MLV 1005-18.39-0 as part of the PSEP Line 1005 Replacement Project³.
2. Land Issues: The Project Team did not anticipate any land issues for this project.
3. DOT Class: This project is in a Class 3 location.

³ Ibid

Pipeline Safety Enhancement Plan Final Report
Line 1005 Santa Barbara Valve Enhancement Project

4. Power Source: There was no preexisting power source, the Project Team installed new power equipment at the site.
5. Communication Technology: There was no preexisting communications equipment, the Project Team installed new communications equipment at the site.

C. Engineering, Design, and Planning Factors

SoCalGas and SDG&E reviewed drawings and records, contacted internal planning groups, communicated with external stakeholders, and completed a pre-design site walk. Key factors that influenced the engineering and design of the Project are as follows:

1. Engineering Assessment: During the site evaluation, the Project Team confirmed the existing technology. There were items of note that affected the design.
2. Valve Details: The existing valve was a manually operated Class 600 ball valve that the Project Team reused.
3. Actuator Details: There was no preexisting actuator, the Project Team installed a new actuator.
4. Customer Impact: The Project Team did not anticipate service disruptions to customers.
5. Community Impact: Employees of the greenhouse frequent the Project location. The Project Team planned construction activities to limit the impact to their daily activities.
6. Substructures: The Project Team did not identify any existing substructures that affected the design and engineering at this site.

Pipeline Safety Enhancement Plan Final Report
Line 1005 Santa Barbara Valve Enhancement Project

7. Environmental: The Project Team did not identify any notable environmental concerns at the site. An environmental monitor performed spot checks during construction.
8. Permit Restrictions: There were no special permits or permit restrictions for this project site.
9. Land Use: The Project Team performed all work within the existing SoCalGas easement.
10. Traffic Control: The Project Team did not identify any traffic control needs at the site.

Pipeline Safety Enhancement Plan Final Report
Line 1005 Santa Barbara Valve Enhancement Project

Figure 2: Line 1005 Santa Barbara Valve Enhancement Project Schematic

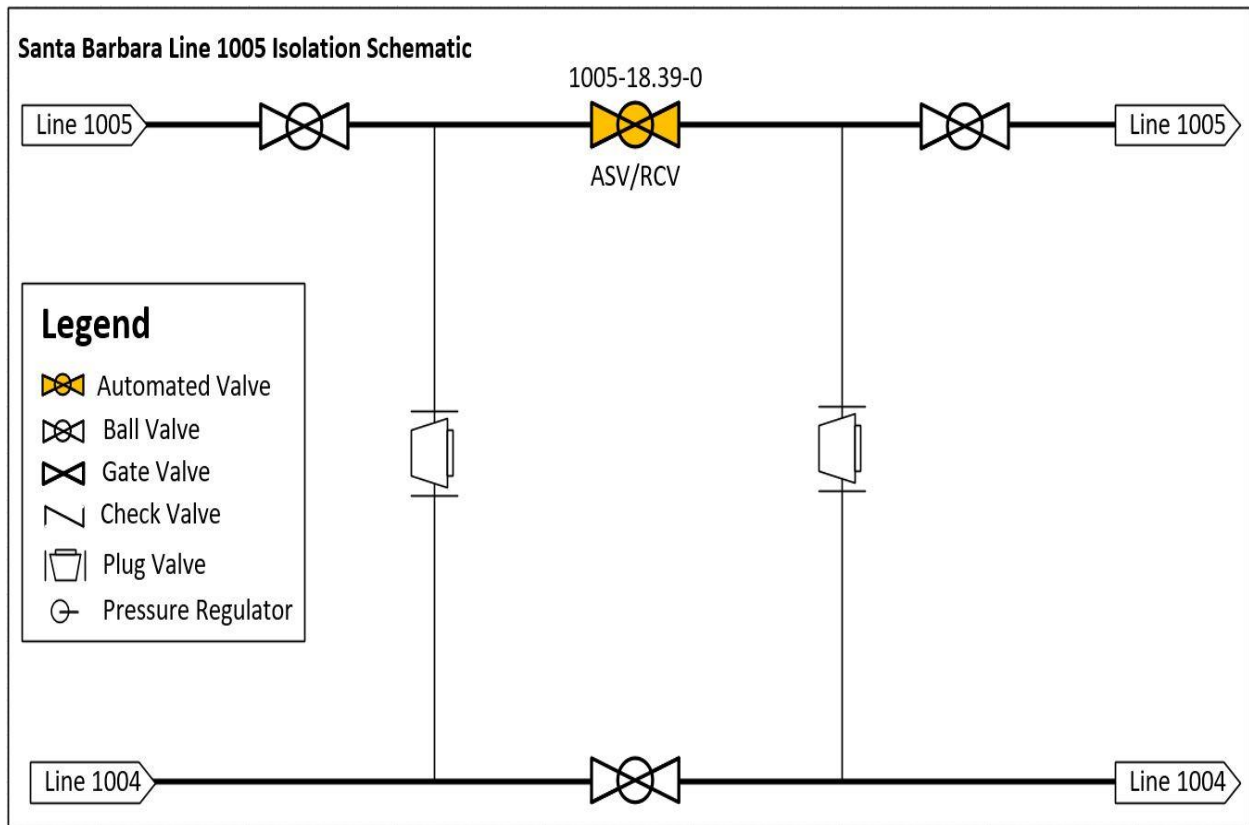

Pipeline Safety Enhancement Plan Final Report
Line 1005 Santa Barbara Valve Enhancement Project

D. Scope Changes

Through engineering, design, and planning activities, SoCalGas and SDG&E determined that changes in scope were appropriate to enhance the design of the Project and address engineering factors. As a result, the preliminary cost estimate does not fully reflect the final scope. Summarized below are notable changes in scope made after the preliminary cost estimate was developed and approved.

1. The Project Team's preliminary estimate assumed installation costs of new MLV 1005-18.39-0; however, the cost of installing the new valve was recorded as a cost in the Line 1005 PSEP Replacement Project⁴. This valve is now known as MLV 1005-18.90-0.
2. The Project Team originally planned to install utility communications at the site. The Project Team learned that four-wire communication would not be available and altered the design to incorporate radio communications.

⁴ Submitted for reasonableness review in A.16-09-005 in workpapers WP-III-A1 – WP-III-A17.

Pipeline Safety Enhancement Plan Final Report
Line 1005 Santa Barbara Valve Enhancement Project

III. CONSTRUCTION

A. Construction Contractor Selection

The Project Team prepared an initial cost estimate based on the preliminary design. Following completion of the engineering, design, and planning activities described above, the Project Team directed the Alliance Partner (Electrical Contractor) to prepare cost estimates based on a more detailed engineering design package, that included the updated design described in the discussion of notable changes in scope above.

1. SoCalGas and SDG&E’s Preliminary Electrical Contractor Estimate (confidential): SoCalGas and SDG&E’s preliminary cost estimate for construction was [REDACTED].
2. Electrical Contractor’s Estimate (confidential): The Electrical Contractor’s estimate was [REDACTED], which was [REDACTED] than SoCalGas and SDG&E’s preliminary cost estimate.

B. Construction Schedule

Table 3: Construction Timeline

Construction Start Date	03/02/2015
Construction Completion Date	04/23/2015
Days on Site	18 days
Commissioning Date	03/10/2016

The Project Team completed all construction activities as soon as practicable prior to commissioning. SoCalGas and SDG&E’s finalization of commissioning activities is dependent on electrical utility connections, and system and/or resource availability.

Pipeline Safety Enhancement Plan Final Report
Line 1005 Santa Barbara Valve Enhancement Project

C. Changes During Construction

The conditions summarized below were encountered during construction. Activities to address or mitigate these conditions resulted in approximately \$29,000 in change orders.

1. Utilities:

- a. SoCalGas and SDG&E determined that four-wire communications were not available and modified the design to incorporate radio communications.
- b. SoCalGas and SDG&E purchased additional materials for the radio communications.
- c. SoCalGas and SDG&E had to install additional conduit and cable to accommodate radio communications.
- d. Additional fittings were required beyond what was indicated in the drawings to connect the site to utility power.

Pipeline Safety Enhancement Plan Final Report
Line 1005 Santa Barbara Valve Enhancement Project

Figure 3: Project Site Prior to Site Restoration



Pipeline Safety Enhancement Plan Final Report
Line 1005 Santa Barbara Valve Enhancement Project

D. Commissioning and Site Restoration

Commissioning activities included site restoration, final inspections, and placement of the valve back into service. During this stage, SoCalGas and SDG&E successfully performed site acceptance testing and conducted point-to-point verification with SoCalGas Gas Control personnel for the newly-automated valve. SoCalGas and SDG&E trained Field Operations personnel on the proper use and operation of the new equipment. Closeout activities included development of final drawings, the reconciliation package, and updates to company recordkeeping systems to reflect the completed scope of work. The site was commissioned on March 10, 2016, as summarized in Table 3.

Pipeline Safety Enhancement Plan Final Report
Line 1005 Santa Barbara Valve Enhancement Project

IV. PROJECT COSTS

A. Cost Avoidance Actions

SoCalGas and SDG&E exercised due diligence in the design, planning, and construction activities for this project to minimize or avoid costs when prudent to do so. As discussed above, the Project Team reviewed existing records, communicated with external stakeholders and conducted a pre-design site walk to incorporate known site conditions in the Project plan and design. As mentioned previously, the PSEP Line 1005 Replacement Project installed the valve as a part of their scope of work, avoiding an additional blowdown and tie-in.

B. Cost Estimates

Based on the preliminary design, once the preliminary project scope was confirmed and engineering, design, and planning activities were underway, SoCalGas and SDG&E prepared an estimate of the Direct Costs of the Project in the amount of \$408,274. This estimate was prepared in May of 2014, using the “Stage 3 SCG Valve Estimate Template Rev 0” estimating tool, the most current version of the PSEP Estimate Template at the time. The Project Team considered the conditions known at the time to prepare the preliminary Direct Cost estimate. This estimate reflects the projected Labor, Material and Services costs anticipated to be incurred to execute the Project based on initial design plans.

SoCalGas and SDG&E estimated Indirect Costs of the Project based on the estimated Direct Costs and other project-related variables.

Pipeline Safety Enhancement Plan Final Report
Line 1005 Santa Barbara Valve Enhancement Project

C. Actual Direct and Indirect Costs

Actual Direct Costs reflect the Labor, Material, and Services costs incurred to execute the Project. Actual Indirect Costs reflect costs for incremental overhead loaders in accordance with Company overhead allocation policies. The total loaded cost of the Project is \$516,400.

Table 4: Estimated and Actual Direct Costs and Variances

Direct Costs (\$)	Estimate	Actuals	Delta Over/(Under)
Company Labor	30,770	78,953	48,183
Materials	138,683	97,872	(40,811)
Mechanical Construction Contractor	141,658	-	(141,658)
Electrical Contractor	27,500	88,631	61,131
Construction Management & Support	8,800	56,052	47,252
Environmental	-	-	-
Engineering & Design	-	20,396	20,396
Project Management & Services	1,538	23,799	22,261
ROW & Permits	44,000	2,096	(41,904)
GMA	15,325	47,839	32,514
Total Direct Costs	408,274	415,638	7,364

Table 5: Estimated and Actual Indirect Costs, Total Costs, and Variances

Indirect Costs/Total Costs (\$)	Estimate	Actuals	Delta Over/(Under)
Overheads	88,427	82,431	(5,996)
AFUDC	14,316	16,049	1,733
Property Taxes	2,704	2,282	(422)
Total Indirect Costs	105,447	100,762	(4,685)
Total Direct Costs	408,274	415,638	7,364
Total Loaded Costs	513,721	516,400	2,679

Pipeline Safety Enhancement Plan Final Report
Line 1005 Santa Barbara Valve Enhancement Project

V. CONCLUSION

SoCalGas and SDG&E enhanced the safety of their integrated natural gas system by prudently executing the Line 1005 Santa Barbara Valve Enhancement Project. Through this Valve Enhancement Project, SoCalGas and SDG&E successfully automated one mainline valve to achieve the objective of enabling rapid system isolation in Santa Barbara County. The total loaded cost of the Project is \$516,400.

SoCalGas and SDG&E executed this project prudently through designing and executing the Project to support achievement of Valve Enhancement Plan isolation objectives, responding to unanticipated changes by modifying the design from four-wire communication to radio communications, and by installing the equipment necessary to bring utility power to this valve to enable rapid automated isolation to a portion of Line 1005 in Santa Barbara County.

SoCalGas and SDG&E engaged in prudent cost avoidance efforts to complete this safety enhancement at a reasonable cost by scheduling the installation of a new mainline valve during the Line 1005 Replacement Project, engaging in reasonable efforts to promote competitive and market-based rates for contractor services and materials, and using a reasonable amount of Company and contractor resources to complete this safety enhancement as soon as practicable.

End of Santa Barbara Line 1005 Valve Enhancement Project Final Report

Pipeline Safety Enhancement Plan Final Report
Line 1014 Brea Valve Enhancement Project Bundle

I. LINE 1014 BREA VALVE ENHANCEMENT PROJECT BUNDLE

A. Background and Summary

This report describes the activities associated with the Line 1014 Brea Valve Enhancement Project Bundle that consists of valve enhancements to one new, mainline valve (MLV), one existing MLV, and two existing bridle valves in the Cities of Anaheim and Lakewood in Orange County and Los Angeles County. Through this project, SoCalGas and SDG&E enhanced the capabilities of two MLVs and two crossover valves to enable rapid transmission system isolation to a portion of Line 1014. SoCalGas and SDG&E installed a new mainline valve, four new actuators, four new vaults to house the actuators, a new blowdown assembly, two check valves, and new power equipment, new communications equipment, and the necessary automation equipment at the sites. The total loaded project cost is \$7,297,034.

The valves comprising the Line 1014 Brea Valve Enhancement Project Bundle are located in urban areas and are separated into two project sites. The Brookhurst Street site is in a parking lot in a high density commercial area. The Bloomfield Avenue site is off of Del Amo Boulevard in a high density area that is a mix of commercial and residential. SoCalGas and SDG&E grouped the two project sites into a single valve bundle and executed the two sites as a comprehensive package because the sites are geographically proximate and are in locations where work could be performed simultaneously, such that the Contractors could manage the work load between project sites and capture efficiencies.

Pipeline Safety Enhancement Plan Final Report
Line 1014 Brea Valve Enhancement Project Bundle

Table 1: General Project Information

Line 1014 Brea Valve Enhancement Project Bundle			
Site	Brookhurst Street	Bloomfield Avenue	
Location	City of Anaheim	City of Lakewood	
Days on Site	52 days	49 days	
Construction Start	11/15/2015	02/01/2016	
Construction Finish	06/16/2016	06/15/2016	
Commissioning Date	05/02/2017	10/04/2016	
Valve Upgrades			
Valve Number	1014-4.89-0	1014-10.88-0	
Valve Type	Existing – Ball	New – Ball	
Actuator	New	New	
Actuator Above-/Below-Grade	Below-Grade	Below-Grade	
ASV	Yes	Yes	
RCV	Yes	Yes	
Valve Number	1014-4.89-1	N/A	
Valve Type	Existing – Ball	New – Check	
Actuator	New	N/A	
Actuator Above-/Below-Grade	Below-Grade	Below-Grade	
ASV	No	N/A	
RCV	Yes	N/A	
Valve Number	1014-4.89-2	N/A	
Valve Type	Existing – Ball	New – Check	
Actuator	New	N/A	
Actuator Above-/Below-Grade	Below-Grade	Below-Grade	
ASV	No	N/A	
RCV	Yes	N/A	
Site Upgrades			
Vault	New – Three	New	
Power	New – Utility	New – Utility	
Communication	New – Radio	New – Radio	
SCADA Panel	New	New	
Equipment Shelter	None	None	
Fencing/Wall	None	None	
Project Costs (\$)	Capital	O&M	Total
Loaded Project Costs	7,297,034	-	7,297,034
Disallowed Costs	-	-	-

Pipeline Safety Enhancement Plan Final Report
Line 1014 Brea Valve Enhancement Project Bundle

B. Maps and Images

Figure 1: Satellite Image of Line 1014 Brea Valve Enhancement Project Bundle: Overview



Pipeline Safety Enhancement Plan Final Report Line 1014 Brea Valve Enhancement Project Bundle

Figure 2: Satellite Image of Brookhurst Street



Pipeline Safety Enhancement Plan Final Report Line 1014 Brea Valve Enhancement Project Bundle

Figure 3: Satellite Image of Bloomfield Avenue



Pipeline Safety Enhancement Plan Final Report
Line 1014 Brea Valve Enhancement Project Bundle

II. ENGINEERING, DESIGN, AND PLANNING

A. Project Scope

SoCalGas and SDG&E presented a conceptual project scope in workpapers supporting the Valve Enhancement Plan¹ in the 2011 filing. This conceptual scope identified two MLVs for automation to provide remote isolation to a portion of Line 1014. Prior to initiating execution of the Project, SoCalGas and SDG&E reviewed available information and performed a detailed system flow analysis to validate the scope of the Project. This resulted in the identification of two additional valves for enhancement to provide the planned isolation. The final project scope is summarized in Table 2 below.

1. 2011 PSEP Filing: SoCalGas and SDG&E identified MLVs 1014-4.89-0 and 1014-10.60-0 for automation to achieve the objective of rapid system isolation.
2. Updated Scope:
 - a. Upon project initiation, SoCalGas and SDG&E reviewed the conceptual project scope and determined that automation of these valves alone would not achieve the transmission isolation objectives set forth in the Valve Enhancement Plan. The Project Team determined that it was also necessary to automate valves 1014-4.89-1 and 1014-4.89-2 to prevent backflow onto Line 1014.

¹ See Workpapers supporting Amended Pipeline Safety Enhancement Plan (PSEP) of SoCalGas and SDG&E, submitted on December 2, 2011, at WP-IX-2-14 through WP-IX-2-25 (A.11-11-002 Exh. # SCG-32).

Pipeline Safety Enhancement Plan Final Report Line 1014 Brea Valve Enhancement Project Bundle

- b. SoCalGas and SDG&E reevaluated the isolation point at MLV 1014-10.60-0 and determined that the automation of MLV 1014-10.95-0 would better achieve the objectives set forth in the Valve Enhancement Plan. There is a bridle around MLV 1014-10.95-0 to Supply Line 42-89. Installing check valves on these bridle taps would prevent any service interruptions to the customers serviced by Supply Line 42-89 in the case of a linebreak on Line 1014.
3. Engineering, Design, and Constructability: MLV 1014-10.95-0 was located in the heavily traveled intersection of Del Amo Boulevard and Bloomfield Avenue. Automating this valve at this site would have resulted in an increase in construction costs and a significant impact on the community during construction. To mitigate these impacts, the preexisting MLV 1014-10.95-0 was removed and a new MLV was installed approximately 370 feet to the east, away from the intersection. The new MLV is now 1014-10.88-0.
4. Final Project Scope: The final project scope consists of the automation of two four valves that included the installation of a new MLV, the installation of two new bridle valves, the installation of four new actuators, the installation of four new vaults to house the actuators, the installation of a new blowdown assembly, the installation of power equipment, the installation of communications equipment, the installation of the necessary automation equipment, and the installation of two new check valves.

Pipeline Safety Enhancement Plan Final Report
Line 1014 Brea Valve Enhancement Project Bundle

Table 2: Final Project Scope

Final Project Scope					
Line	Mile	Valve #	Valve Size (<i>confidential</i>)	Installation Type	Function
1014	4.89	0	████████	A/VT	ASV/RCV
1014	4.89	1	████████	A/VT	RCV
1014	4.89	2	████████	A/VT	RCV
1014	10.88	0	████████	NV/VT	ASV/RCV
42-89	0	Check	████████	NV	BFP2
42-89BP2	0	Check	████████	NV	BFP2

B. Site Evaluation and Planning

SoCalGas and SDG&E initiated the planning process for the Line 1014 Brea Valve Enhancement Project Bundle by performing pre-design site walks to determine the existing conditions and assess any potential impacts on the design. Key factors that influenced the engineering and design of this project are as follows:

Brookhurst Street

1. Site Description: This project site is in the parking lot of a church in a high density commercial area.
2. Land Issues: During the pre-design site walk, the Project Team noted that a Temporary Right of Entry (TRE) would be needed from the church.
3. DOT Class: This project site is in a Class 3 location.
4. Power Source: There was no preexisting power source, the Project Team installed new power equipment at the site.

Pipeline Safety Enhancement Plan Final Report
Line 1014 Brea Valve Enhancement Project Bundle

5. Communication Technology: There was no preexisting communications equipment, the Project Team installed new communications equipment at the site.

Bloomfield Avenue

1. Site Description: This Project Site is located in a high density area that is a commercial and residential mix. MLV 1014-10.95-0 was located in the intersection of Bloomfield Avenue and Del Amo Boulevard. There was a preexisting bridge to Supply Line 42-89 around the MLV. The Project Team noted that performing work in this location would have resulted in high construction costs and would have created a notable impact to the community. The Project Team elected to remove the preexisting MLV 1014-10.95-0 and installed a new valve approximately 370 feet east on Del Amo Boulevard in a more accessible and safer location.
2. Land Issues: During the pre-design site walk, the Project Team noted that excavations will impact the street as well as the adjacent sidewalk.
3. DOT Class: This project site is in a Class 3 location.
4. Power Source: There was no preexisting power source, the Project Team installed new power equipment at the site.
5. Communication Technology: There was no preexisting communications equipment, the Project Team installed new communications equipment at the site.

Pipeline Safety Enhancement Plan Final Report
Line 1014 Brea Valve Enhancement Project Bundle

C. Engineering, Design, and Planning Factors

SoCalGas and SDG&E reviewed drawings and records, contacted internal planning groups, communicated with external stakeholders, conducted survey activity, performed potholing of the area to identify the presence of underground utilities and substructures, and completed a pre-design site walk. Key factors that influenced the engineering and design of the Project are as follows:

Brookhurst Street

1. Engineering Assessment: The Project Team confirmed the preexisting technology and verified the specifications of the valves. The Project Team determined that installing the new actuators in vaults as opposed to above-grade would increase public safety and minimize impacts to the community.
2. Valve Details:
 - a. 1014-4.89-0: The existing valve was a manually operated Class 300 ball valve that the Project Team reused.
 - b. 1014-4.89-1: The existing valve was a manually operated Class 300 ball valve that the Project Team reused.
 - c. 1014-4.89-2: The existing valve was a manually operated Class 300 ball valve that the Project Team reused.
3. Actuator Details:
 - a. 1014-4.89-0: There was no preexisting actuator, the Project Team installed a new actuator.

Pipeline Safety Enhancement Plan Final Report
Line 1014 Brea Valve Enhancement Project Bundle

- b. 1014-4.89-1: There was no preexisting actuator, the Project Team installed a new actuator.
- c. 1014-4.89-2: There was no preexisting actuator, the Project Team installed a new actuator.
- 4. Customer Impact: The Project Team did not anticipate service disruptions to customers.
- 5. Community Impact: This Project site is located in a church parking lot. The Project Team planned construction activities to limit impacts to the church's congregation.
- 6. Substructures: The Project Team did not identify any existing substructures that affected the design and engineering at this site.
- 7. Environmental: The Project Team did not identify any environmental concerns at the site. An environmental monitor completed spot checks during construction.
- 8. Permit Restrictions: The Project Team obtained an Encroachment Permit from the City of Anaheim.
- 9. Land Use: The Project Team utilized the church parking lot as a laydown and staging area during construction.
- 10. Traffic Control: The Project Team sectioned off a portion of the church parking lot during construction. There was no traffic control required on public roads.

Pipeline Safety Enhancement Plan Final Report
Line 1014 Brea Valve Enhancement Project Bundle

Bloomfield Avenue

1. Engineering Assessment: The Project Team determined that a more cost effective and less impactful design would be to remove MLV 1014-10.95-0, install a new MLV and bridle configuration approximately 370 feet to the west, and extend Supply Line 42-89 to the new bridle configuration. The Project Team selected the new location as it was the closest location to the existing valve where a vault could be installed in the side walk.
2. Valve Details: The preexisting valve was a manually operated Class 300 ball valve that the Project Team removed.
3. Actuator Details: There was no preexisting actuator, the Project Team installed a new actuator.
4. Customer Impact: Line 1014 serves multiple local power plants; the Project Team coordinated the shut-in of Line 1014 with the maintenance schedules of the power plants avoiding the need for CNG/LNG support.
5. Community Impact: The Project Team restricted public access to the sidewalk during construction.
6. Substructures: The Project Team did not identify any existing substructures that affected the design and engineering at this site.
7. Environmental: The Project Team did not identify any environmental concerns at the site. An environmental monitor performed spot checks during construction.
8. Permit Restrictions: The Project Team obtained Encroachment Permits from the cities of Cerritos and Lakewood and a utility excavation permit from Los Angeles County.

Pipeline Safety Enhancement Plan Final Report
Line 1014 Brea Valve Enhancement Project Bundle

9. Land Use: The Project Team utilized the closed traffic lane as a staging and laydown area during construction.

10. Traffic Control: The Project Team closed one traffic lane during construction for excavation. The Project Team plated the excavation during non-working hours to allow traffic to pass through unimpeded during non-construction hours.

Pipeline Safety Enhancement Plan Final Report Line 1014 Brea Valve Enhancement Project Bundle

Figure 4: Brea Line 1014 Valve Enhancement Project Bundle Schematic

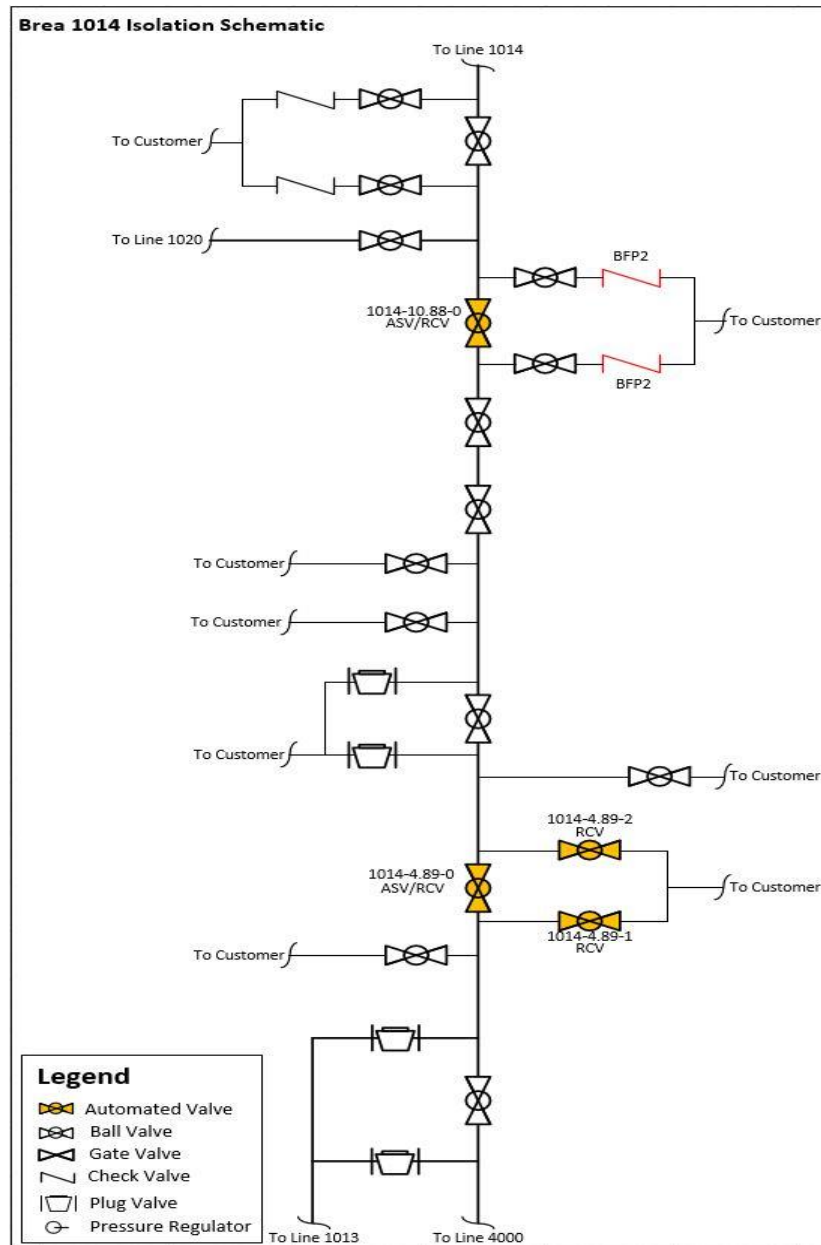

Pipeline Safety Enhancement Plan Final Report
Line 1014 Brea Valve Enhancement Project Bundle

D. Scope Changes

SoCalGas and SDG&E did not make any notable scope changes during detailed design.

Pipeline Safety Enhancement Plan Final Report
Line 1014 Brea Valve Enhancement Project Bundle

III. CONSTRUCTION

A. Construction Contractor Selection

The Project Team prepared an initial cost estimate based on the preliminary design. Following completion of the engineering, design, and planning activities described above, the Project Team directed the Performance Partner (Mechanical Construction Contractor) and Alliance Partner (Electrical Contractor) to prepare cost estimates based on a more detailed engineering design package. As indicated above, there were no notable changes in scope between the time when the Project Team prepared the preliminary cost estimate and when the Performance Partner and Alliance Partner prepared and submitted their estimates.

1. SoCalGas and SDG&E's Preliminary Mechanical Construction Contractor Estimate (*confidential*): SoCalGas and SDG&E's preliminary cost estimate for construction was [REDACTED].
2. Mechanical Construction Contractor's Target Price Estimate (TPE) (*confidential*): The Mechanical Construction Contractor's cost estimate was [REDACTED], which was [REDACTED] than SoCalGas and SDG&E's preliminary cost estimate for construction.
3. SoCalGas and SDG&E's Preliminary Electrical Contractor Estimate (*confidential*): SoCalGas and SDG&E's preliminary cost estimate for construction was [REDACTED].
4. Electrical Contractor's Estimate (*confidential*): The Electrical Contractor's estimate was [REDACTED], which was [REDACTED] than SoCalGas and SDG&E's preliminary cost estimate.

Pipeline Safety Enhancement Plan Final Report
Line 1014 Brea Valve Enhancement Project Bundle

B. Construction Schedule

Table 3: Construction Timeline

Brookhurst Street	
Construction Start Date	11/15/2015
Construction Completion Date	06/16/2016
Days on Site	52 days
Commissioning Date	05/02/2017
Bloomfield Avenue	
Construction Start Date	02/01/2016
Construction Completion Date	06/15/2016
Days on Site	49 days
Commissioning Date	10/04/2016

The Project Team completed all construction activities as soon as practicable prior to commissioning. SoCalGas and SDG&E’s finalization of commissioning activities is dependent on electrical utility connections, and system and/or resource availability.

C. Changes During Construction

The conditions summarized below were encountered during construction. Activities to address or mitigate these conditions resulted in approximately \$366,000 in change orders.

1. **Construction Execution:** The Mechanical Construction Contractor initially planned to utilize beam shoring. The Project Team determined that due to the complexity and duration of the required excavation and demolition work, the use of plate shoring would provide an increased level of safety for the construction crews and the general public.

Pipeline Safety Enhancement Plan Final Report
Line 1014 Brea Valve Enhancement Project Bundle

2. Traffic: The Mechanical Construction Contractor's TPE was based on a preliminary version of the Traffic Control Plan. During the permitting process, the Project Team received comments from Los Angeles County requesting that temporary pavement markings, temporary crash cushions, temporary hand railings, and additional traffic cones be utilized during construction. Los Angeles County also requested that the excavation be plated during non-working hours. The Project Team updated the Traffic Plan from what was utilized to create the TPE.
3. Schedule: Construction was extended for 13 working days beyond what the Mechanical Construction Contractor assumed in the TPE due to conditions encountered during construction. These conditions include changes to the Traffic Control Plans requested by Los Angeles County; the utilization of plate shoring; excavation, abatement, and demolition of the abandoned vault; and the extension of the tie-in activities as discussed.
4. Substructures:
 - a. The Mechanical Construction Contractor encountered an abandoned vault during construction that interfered with construction activities. The vault was demolished and the retired actuator inside was abated and removed.
 - b. The Mechanical Construction Contractor encountered an abandoned pipe fitting during excavation at the planned location for the fire control fitting. The Mechanical Construction Contractor installed the fire control fitting at a different location.
5. Tie-In: The Project Team initially planned for a two day tie-in and, due to complex gas handling and isolation activities, the tie-in was extended to three days.

Pipeline Safety Enhancement Plan Final Report Line 1014 Brea Valve Enhancement Project Bundle

Figure 5: Brookhurst Street Project Site – Mainline Valve Excavation



Pipeline Safety Enhancement Plan Final Report
Line 1014 Brea Valve Enhancement Project Bundle

Figure 6: Bloomfield Avenue Project Site – New Mainline Valve and Blowdown Assembly
Installation



Pipeline Safety Enhancement Plan Final Report
Line 1014 Brea Valve Enhancement Project Bundle

D. Commissioning and Site Restoration

Commissioning activities included site restoration, final inspections, and placement of the valves back into service. During this stage, SoCalGas and SDG&E successfully performed site acceptance testing and conducted point-to-point verification with SoCalGas Gas Control personnel for the newly-automated valves. SoCalGas and SDG&E trained Field Operations personnel on the proper use and operation of the new equipment. Closeout activities included development of final drawings, the reconciliation package, and updates to company recordkeeping systems to reflect the completed scope of work. The sites were commissioned on October 4, 2016 and May 2, 2017, as summarized in Table 3.

Pipeline Safety Enhancement Plan Final Report
Line 1014 Brea Valve Enhancement Project Bundle

IV. PROJECT COSTS

A. Cost Avoidance Actions

SoCalGas and SDG&E exercised due diligence in the design, planning, and construction activities for this project to minimize or avoid costs when prudent to do so. As discussed above, the Project Team reviewed existing records, communicated with external stakeholders, and conducted a site walk to incorporate the known site conditions in the project plan and design. Specific examples of cost avoidance actions taken on this project were:

1. Planning and Coordination:
 - a. The Project Team bundled projects to coordinate engineering and construction activity between the three project sites.
 - b. The Project Team scheduled construction so that the shut-in aligned with the customer's maintenance schedule, thus avoiding the need for CNG or LNG.

B. Cost Estimates

Based on the preliminary design, once the preliminary project scope was confirmed and engineering, design, and planning activities were underway, SoCalGas and SDG&E prepared an estimate of the Direct Costs of the Project in the amount of \$4,956,409. This estimate was prepared in April of 2015, using the "Stage 3 SCG Valve Estimate Template Rev 2" estimating tool, the most current version of the PSEP Estimate Template at the time. The Project Team considered the conditions known at the time to prepare the preliminary Direct Cost estimate. This estimate reflects the projected Labor, Material, and Services costs anticipated to be incurred to execute the Project, based on initial design plans.

Pipeline Safety Enhancement Plan Final Report
Line 1014 Brea Valve Enhancement Project Bundle

SoCalGas and SDGE estimated Indirect Costs of the Project based on the estimated Direct Costs and other project-related variables.

C. Actual Direct and Indirect Costs

Actual Direct Costs reflect the Labor, Material, and Services costs incurred to execute the Project. Actual Indirect Costs reflect costs for incremental overhead loaders in accordance with Company overhead allocation policies. The total loaded cost of the Project is \$7,297,034.

Table 4: Estimated and Actual Direct Costs and Variances

Direct Costs (\$)	Estimate	Actuals	Delta Over/(Under)
Company Labor	201,853	400,939	199,086
Materials	602,077	562,481	(39,596)
Mechanical Construction Contractor	1,959,480	2,494,925	535,445
Electrical Contractor	321,549	259,958	(61,591)
Construction Management & Support	270,930	527,647	256,717
Environmental	106,101	143,756	37,655
Engineering & Design	514,253	963,287	449,034
Project Management & Services	358,949	210,141	(148,808)
ROW & Permits	97,369	112,136	14,767
GMA	523,848	739,822	215,974
Total Direct Costs	4,956,409	6,415,092	1,458,683

Pipeline Safety Enhancement Plan Final Report
Line 1014 Brea Valve Enhancement Project Bundle

Table 5: Estimated and Actual Indirect Costs, Total Costs, and Variances

Indirect Costs/Total Costs (\$)	Estimate	Actuals	Delta Over/(Under)
Overheads	460,206	630,020	169,814
AFUDC	334,750	213,142	(121,608)
Property Taxes	71,251	38,780	(32,471)
Total Indirect Costs	866,207	881,942	15,735
Total Direct Costs	4,956,409	6,415,092	1,458,683
Total Loaded Costs	5,822,616	7,297,034	1,474,418

Pipeline Safety Enhancement Plan Final Report
Line 1014 Brea Valve Enhancement Project Bundle

V. CONCLUSION

SoCalGas and SDG&E enhanced the safety of their integrated natural gas system by prudently executing the Line 1014 Brea Valve Enhancement Project Bundle. Through this Valve Enhancement Project Bundle, SoCalGas and SDG&E successfully automated two mainline valves, two crossover valves, and installed two check valves to achieve the objective of enabling rapid system isolation in the Cities of Anaheim and Lakewood. The total loaded cost of the Project is \$7,297,034.

SoCalGas and SDG&E executed this project prudently through designing and executing the Project to support achievement Valve Enhancement Plan isolation objectives, coordinating and bundling two valve projects into a comprehensive construction package to capture efficiencies through coordinated scheduling of construction crews, and installing equipment necessary to bring power and communication capabilities to these valves to enable rapid system isolation to portions of Line 1014.

SoCalGas and SDG&E engaged in prudent cost avoidance efforts to complete this safety enhancement work at a reasonable cost by carefully planning and coordinating construction activity, and by limiting the number of mobilizations across two different project sites to maximize efficiencies and reduce customer and community impacts.

End of Line 1014 Valve Enhancement Project Bundle Final Report

Pipeline Safety Enhancement Plan Final Report
Line 1018 Dana Point Valve Enhancement Project

I. LINE 1018 DANA POINT VALVE ENHANCEMENT PROJECT

A. Background and Summary

This report describes the activities associated with the Line 1018 Dana Point Valve Enhancement Project that consists of valve enhancements made to an existing mainline valve (MLV) located in the City of Dana Point in Orange County. Through this project, SoCalGas and SDG&E enhanced the capabilities of one MLV to enable rapid transmission system isolation to a portion of Line 1018. SoCalGas and SDG&E installed a new actuator, and the necessary automation equipment at the site. The total loaded project cost is \$734,125.

The Line 1018 Dana Point Valve Enhancement Project site is located in an existing SoCalGas facility in the City of Dana Point Near Highway One.

Pipeline Safety Enhancement Plan Final Report
Line 1018 Dana Point Valve Enhancement Project

Table 1: General Project Information

Line 1018 Dana Point Valve Enhancement Project			
Location	City of Dana Point		
Days on Site	22 days		
Construction Start	10/10/2016		
Construction Finish	11/09/2016		
Commissioning Date	12/07/2016		
Valve Upgrades			
Valve Number	1018-24.86-0		
Valve Type	Existing – Ball		
Actuator	New		
Actuator Above-/Below-Grade	Above-Grade		
ASV	No		
RCV	Yes		
Site Upgrades			
Vault	None		
Power	Existing – Utility		
Communication	Existing – Radio		
SCADA Panel	Yes		
Equipment Shelter	No		
Fencing/Wall	Existing – Fencing and Retaining Wall		
Project Costs (\$)	Capital	O&M	Total
Loaded Project Costs	734,125	-	734,125
Disallowed Costs	-	-	-

Pipeline Safety Enhancement Plan Final Report
 Line 1018 Dana Point Valve Enhancement Project

B. Maps and Images

Figure 1: Satellite Image of Line 1018 Dana Point Site



Pipeline Safety Enhancement Plan Final Report
Line 1018 Dana Point Valve Enhancement Project

II. ENGINEERING, DESIGN, AND PLANNING

A. Project Scope

SoCalGas and SDG&E presented a conceptual project scope in workpapers supporting the Valve Enhancement Plan¹ in the 2011 filing. This conceptual scope did not include this project. SoCalGas and SDG&E reviewed available information and performed a detailed system flow analysis that identified this valve as a candidate for enhancement to provide the planned isolation. The final project scope is summarized in Table 2 below.

1. 2011 PSEP Filing: SoCalGas and SDG&E did not identify this valve for automation to achieve the objective of rapid system isolation.
2. Updated Scope: SoCalGas and SDG&E determined that the automation of MLV 1018-24.86-0 would enable rapid isolation, thereby achieving Valve Enhancement Plan objectives.
3. Engineering, Design, and Constructability: No notable engineering adjustments to the standard design were required.
4. Final Project Scope: The final project scope consists of the automation of one valve that included the installation of a new actuator, and the installation of the necessary automation equipment at the project site.

¹ See Workpapers supporting Amended Pipeline Safety Enhancement Plan (PSEP) of SoCalGas and SDG&E, submitted on December 2, 2011, at WP-IX-2-14 through WP-IX-2-25 (A.11-11-002 Exh. # SCG-32).

Pipeline Safety Enhancement Plan Final Report
Line 1018 Dana Point Valve Enhancement Project

Table 2: Final Project Scope

Final Project Scope					
Line	Mile	Valve #	Valve Size (<i>confidential</i>)	Installation Type	Function
1018	24.86	0	██████	A/AG	RCV

B. Site Evaluation and Planning

SoCalGas and SDG&E initiated the planning process for the Line 1018 Dana Point Valve Enhancement Project by performing a pre-design site walk to determine the existing conditions and assess any potential impacts on the design. Key factors that influenced the engineering and design of this project are as follows:

1. Site Description: This site is an existing SoCalGas facility located in an urban area. There is an existing chain link fence on three sides of the facility and a retaining wall that borders the back side of the facility.
2. Land Issues: During the pre-design site walk, the Project Team noted that the existing facility can accommodate the new equipment.
3. DOT Class: This project site is in a Class 3 location.
4. Power Source: The site has existing utility power.
5. Communication Technology: The site has existing radio communications.

Pipeline Safety Enhancement Plan Final Report
Line 1018 Dana Point Valve Enhancement Project

C. Engineering, Design, and Planning Factors

SoCalGas and SDG&E reviewed drawings and records, contacted internal planning groups, communicated with external stakeholders, conducted survey activity and completed a pre-design site walk. Key factors that influenced the engineering and design of the Project are as follows:

1. Engineering Assessment: During the site evaluation, the Project Team confirmed the existing technology and verified that the station could accommodate the new equipment.
2. Valve Details: The existing valve was a manually operated Class 600 ball valve that the Project Team reused.
3. Actuator Details: There was no preexisting actuator, the Project Team installed a new actuator.
4. Customer Impact: The Project Team did not anticipate service disruptions to customers.
5. Community Impact: The Project Team did not anticipate any notable impacts to the community from this Project.
6. Substructures: The Project Team did not identify any existing substructures that affected the design and engineering of this site.
7. Environmental: The Project Team determined that a temporary water storage tank was required on site during construction due to the presence of a high water table. A wastewater discharge permit was required by South Orange County Wastewater Authority (SOCWA). An environmental monitor performed spot checks during construction.

Pipeline Safety Enhancement Plan Final Report
Line 1018 Dana Point Valve Enhancement Project

8. Permit Restrictions: The Project Team obtained a discharge permit from the South Orange County Wastewater Authority (SOCWA).
9. Land Use: The Project Team performed all work within the existing SoCalGas facility.
10. Traffic Control: The Project Team did not identify any traffic control needs at the site.

Pipeline Safety Enhancement Plan Final Report Line 1018 Dana Point Valve Enhancement Project

Figure 2: Line 1018 Dana Point Valve Enhancement Project Schematic

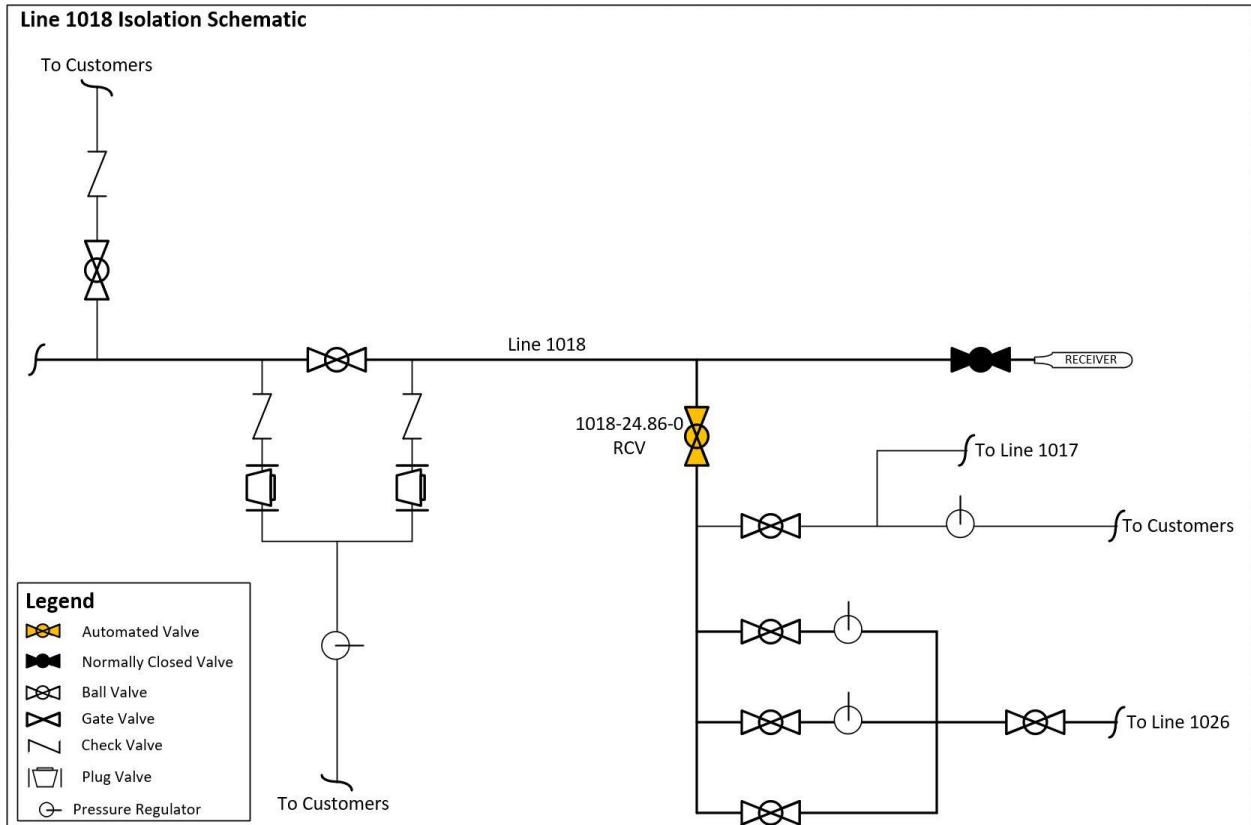

Pipeline Safety Enhancement Plan Final Report
Line 1018 Dana Point Valve Enhancement Project

D. Scope Changes

SoCalGas and SDG&E did not make any notable scope changes during detailed design.

Pipeline Safety Enhancement Plan Final Report
Line 1018 Dana Point Valve Enhancement Project

III. CONSTRUCTION

A. Construction Contractor Selection

The Project Team prepared an initial cost estimate based on the preliminary design. Following completion of the engineering, design, and planning activities described above, the Project Team directed the Performance Partner (Mechanical Construction Contractor) and Alliance Partner (Electrical Contractor) to prepare cost estimates based on a more detailed engineering design package. As indicated above, there were no notable changes in scope between the time when the Project Team prepared the preliminary cost estimate and when the Performance Partner and Alliance Partner prepared and submitted their estimates.

1. SoCalGas and SDG&E's Preliminary Mechanical Construction Contractor Estimate (*confidential*): SoCalGas and SDG&E's preliminary cost estimate for construction was [REDACTED].
2. Mechanical Construction Contractor's Target Price Estimate (*confidential*): The Mechanical Construction Contractor's cost estimate was [REDACTED], that was [REDACTED] than SoCalGas and SDG&E's preliminary cost estimate for construction.
3. SoCalGas and SDG&E's Preliminary Electrical Contractor Estimate (*confidential*): SoCalGas and SDG&E's preliminary cost estimate for construction was [REDACTED].
4. Electrical Contractor's Estimate (*confidential*): The Electrical Contractor's estimate was [REDACTED], that was [REDACTED] than SoCalGas and SDG&E's preliminary cost estimate.

Pipeline Safety Enhancement Plan Final Report
Line 1018 Dana Point Valve Enhancement Project

B. Construction Schedule

Table 3: Construction Timeline

Construction Start Date	10/10/2016
Construction Completion Date	11/09/2016
Days on Site	22 days
Commissioning Date	12/07/2016

The Project Team completed all construction activities as soon as practicable prior to commissioning. SoCalGas and SDG&E’s finalization of commissioning activities is dependent on electrical utility connections, and system and/or resource availability.

C. Changes During Construction

SoCalGas and SDG&E successfully mitigated conditions during construction in a manner that minimized potential impacts on project scope, cost, and schedule. As a result, these conditions did not result in any notable change orders.

Pipeline Safety Enhancement Plan Final Report Line 1018 Dana Point Valve Enhancement Project

Figure 3: New SCADA Panel



Pipeline Safety Enhancement Plan Final Report
Line 1018 Dana Point Valve Enhancement Project

Figure 4: Temporary Storage Tank for Groundwater



Pipeline Safety Enhancement Plan Final Report
Line 1018 Dana Point Valve Enhancement Project

D. Commissioning and Site Restoration

Commissioning activities included site restoration, final inspections, and placement of the actuators into service. During this stage, SoCalGas and SDG&E successfully performed site acceptance testing and conducted point-to-point verification with SoCalGas Gas Control personnel for the newly-automated valve. SoCalGas and SDG&E trained Field Operations personnel on the proper use and operation of the new equipment. Closeout activities included development of final drawings, the reconciliation package, and updates to company recordkeeping systems to reflect the completed scope of work. The site was commissioned on December 7, 2016, as summarized in Table 3.

Pipeline Safety Enhancement Plan Final Report
Line 1018 Dana Point Valve Enhancement Project

IV. PROJECT COSTS

A. Cost Avoidance Actions

SoCalGas and SDG&E exercised due diligence in the design, planning, and construction activities for this project to minimize or avoid costs when prudent to do so. As discussed above, the Project Team reviewed existing records, communicated with external stakeholders, and conducted a pre-design site walk to incorporate the known site conditions in the project plan and design. Specific examples of cost avoidance actions taken on this project were:

1. Land Use: The Project Team utilized existing SoCalGas and SDG&E land for a laydown area.
2. Water Management: The Project Team acquired a wastewater discharge permit allowing the disposal of ground water to the sewer that was directed to the SOCWA facility, avoiding the need to utilize trucks to transport groundwater to a wastewater treatment facility.

Pipeline Safety Enhancement Plan Final Report
Line 1018 Dana Point Valve Enhancement Project

B. Cost Estimates

Based on the preliminary design, once the preliminary project scope was confirmed and engineering, design, and planning activities were underway, SoCalGas and SDG&E prepared an estimate of the Direct Costs of the Project in the amount of \$1,221,644. This estimate was prepared in August of 2016, using the “Stage 3 SCG Estimating Template Rev 3” estimating tool, the most current version of the PSEP Estimate Template at the time. The Project Team considered the conditions known at the time to prepare the preliminary Direct Cost estimate. This estimate reflects the projected Labor, Material and Services costs anticipated to be incurred to execute the Project.

SoCalGas and SDG&E estimated Indirect Costs of the Project based on the estimated Direct Costs and other project-related variables.

C. Actual Direct and Indirect Costs

Actual Direct Costs reflect the Labor, Material, and Services costs incurred to execute the Project. Actual Indirect Costs reflect costs for incremental overhead loaders in accordance with Company overhead allocation policies. The total loaded cost of the Project is \$734,125.

Pipeline Safety Enhancement Plan Final Report
Line 1018 Dana Point Valve Enhancement Project

Table 4: Estimated and Actual Direct Costs and Variances

Direct Costs (\$)	Estimate	Actuals	Delta Over/(Under)
Company Labor	227,589	87,293	(140,296)
Materials	54,464	56,380	1,916
Mechanical Construction Contractor	281,364	178,523	(102,841)
Electrical Contractor	245,438	49,116	(196,322)
Construction Management & Support	34,100	29,554	(4,546)
Environmental	159,137	14,711	(144,426)
Engineering & Design	27,500	60,059	32,559
Project Management & Services	81,534	23,452	(58,082)
ROW & Permits	-	2,777	2,777
GMA	110,518	58,101	(52,417)
Total Direct Costs	1,221,644	559,966	(661,678)

Table 5: Estimated and Actual Indirect Costs, Total Costs, and Variances

Indirect Cost/Total Costs (\$)	Estimate	Actuals	Delta Over/(Under)
Overheads	251,699	97,261	(154,438)
AFUDC	31,457	67,768	36,311
Property Taxes	6,992	9,130	2,138
Total Indirect Costs	290,148	174,159	(115,989)
Total Direct Costs	1,221,644	559,966	(661,678)
Total Loaded Costs	1,511,792	734,125	(777,667)

Pipeline Safety Enhancement Plan Final Report
Line 1018 Dana Point Valve Enhancement Project

V. CONCLUSION

SoCalGas and SDG&E enhanced the safety of their integrated natural gas system by prudently executing the Line 1018 Dana Point Valve Enhancement Project. Through this Valve Enhancement Project, SoCalGas and SDG&E successfully automated one mainline valve to achieve the objective of enabling rapid system isolation in the City of Dana Point. The total loaded cost of the Project is \$734,125.

SoCalGas and SDG&E executed this project prudently through designing and executing the Project to support the achievement of Valve Enhancement Plan isolation objectives, designing and executing the Project within an existing SoCalGas facility eliminating the need to acquire any new property, and by utilizing existing power and communications equipment to enable rapid system isolation to a portion of Line 1018.

SoCalGas and SDG&E engaged in prudent cost avoidance efforts to complete this safety enhancement at a reasonable cost by engaging in reasonable efforts to promote competitive and market-based rates for contractor services and materials, and using a reasonable amount of Company and contractor resources to complete this safety enhancement work as soon as practicable.

End of Line 1018 Dana Point Valve Enhancement Project Final Report

Pipeline Safety Enhancement Plan Final Report
Line 1020 Valve Enhancement Project

I. LINE 1020 VALVE ENHANCEMENT PROJECT

A. Background and Summary

This report describes the activities associated with the Line 1020 Valve Enhancement Project, that consists of valve enhancements made to an existing mainline valve (MLV) in the City of Lakewood in Los Angeles County. Through this project, SoCalGas and SDG&E enhanced the capabilities of MLV 1020-0.01-0 to provide rapid transmission system isolation to a portion of Line 1020. SoCalGas and SDG&E installed a new actuator, a new vault to house the actuator, new power equipment, new communications equipment, and the necessary automation equipment at the site. The total loaded project cost is \$1,664,184.

The Line 1020 Valve Enhancement Project site is located in an area that is a combination of commercial and residential. The valve is located next to a gas station and a single-family home near Del Amo Boulevard. There is an existing launcher in a vault for Line 1020 next to the project site.

Pipeline Safety Enhancement Plan Final Report Line 1020 Valve Enhancement Project

Table 1: General Project Information

Line 1020 Valve Enhancement Project				
Location	City of Lakewood			
Days on Site	38 days			
Construction Start	03/23/2015			
Construction Finish	03/30/2016			
Commissioning Date	06/08/2016			
Valve Upgrades				
Valve Number	1020-0.01-0			
Valve Type	Existing – Ball			
Actuator	New			
Actuator Above-Grade/Below-Grade	Below-Grade			
ASV	Yes			
RCV	Yes			
Site Upgrades				
Vault	New			
Power	New – Utility			
Communication	New – Radio			
SCADA Panel	New			
Equipment Shelter	None			
Fencing/Wall	None			
Project Costs (\$)		Capital	O&M	Total
Loaded Project Costs		1,664,184	-	1,664,184
Disallowed Costs		-	-	-

Pipeline Safety Enhancement Plan Final Report
Line 1020 Valve Enhancement Project

B. Maps and Images

Figure 1: Satellite Image of Line 1020 Valve Enhancement Project

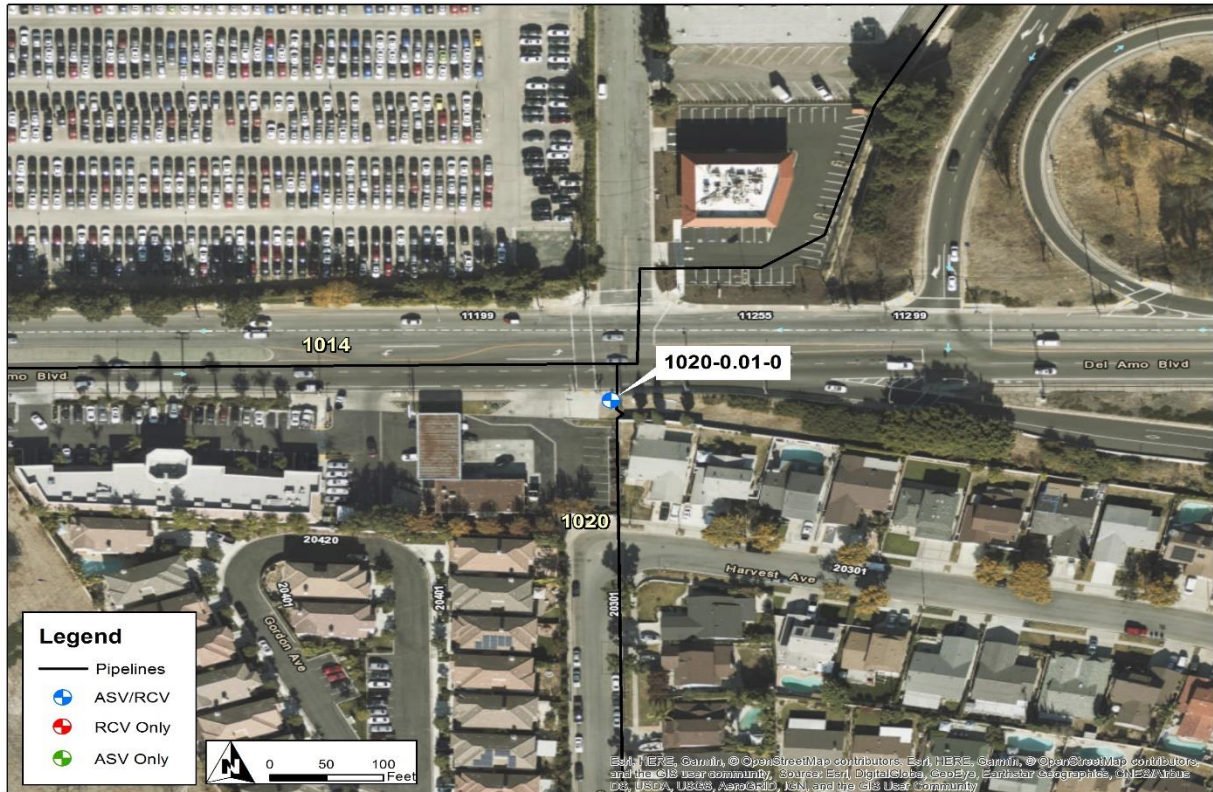

Pipeline Safety Enhancement Plan Final Report
Line 1020 Valve Enhancement Project

II. ENGINEERING, DESIGN, AND PLANNING

A. Project Scope

SoCalGas and SDG&E presented a conceptual project scope in workpapers supporting the Valve Enhancement Plan¹ in the 2011 filing. This conceptual scope identified one MLV 1020-0.01-0, for automation to provide remote isolation to a portion of Line 1020. Prior to initiating execution of the Project, SoCalGas and SDG&E reviewed available information and performed a detailed system flow analysis to validate the scope of the Project, that confirmed this valve enhancement will provide the planned isolation. The final project scope is summarized in Table 2 below.

1. 2011 PSEP Filing: SoCalGas and SDG&E identified MLV 1020-0.01-0 for automation to achieve the objective of rapid system isolation.
2. Updated Scope:
 - a. Upon project initiation, SoCalGas and SDG&E reviewed the conceptual project scope and determined that this isolation point would achieve the transmission isolation objectives set forth in the Valve Enhancement Plan.
 - b. During the scope review, SoCalGas and SDG&E determined that a check valve was required in the meter set assembly at a custody transfer site nearby. SoCalGas and SDG&E bundled that project site with the Line 1020 project.
3. Engineering, Design, and Constructability: After the creation of the preliminary estimate, the Project Team descope the installation of the check valve as the meter set assembly was scheduled to be replaced in the future by the Operating District.

¹ See Workpapers supporting Amended Pipeline Safety Enhancement Plan (PSEP) of SoCalGas and SDG&E, submitted on December 2, 2011, at WP-IX-2-14 through WP-IX-2-25 (A.11-11-002 Exh. # SCG-32).

Pipeline Safety Enhancement Plan Final Report
Line 1020 Valve Enhancement Project

4. **Final Project Scope:** The final project scope consists of the automation of one valve, that included the installation of a new actuator, the installation of a new vault to house the actuator, and the installation of power equipment, the installation of communications equipment, and the installation of the necessary automation equipment at the project site.

Table 2: Final Project Scope

Final Project Scope					
Line	Mile	Valve #	Valve Size (<i>confidential</i>)	Installation Type	Function
1020	0.01	0	██████	A/VT	ASV/RCV

B. Site Evaluation and Planning

SoCalGas and SDG&E initiated the planning process for the Line 1020 Valve Enhancement Project by performing a pre-design site walk to determine the existing conditions and assess any potential impact on the design. Key factors that influenced the engineering and design of this project are as follows:

1. **Site Description:** This site is in a high-density area that is a combination of commercial and residential buildings. The valve is located next to a gas station and a residential area. There is an existing launcher for Line 1020 next to the project site in a vault.
2. **Land Issues:** During the pre-design site walk, the Project Team noted that a temporary easement would be necessary during construction.
3. **DOT Class:** This project is in a Class 3 location.

Pipeline Safety Enhancement Plan Final Report
Line 1020 Valve Enhancement Project

4. Power Source: There was no preexisting power source, the Project Team installed new power equipment at the site.
5. Communication Technology: There was no preexisting communications equipment, the Project Team installed new communications equipment at the site.

C. Engineering, Design, and Planning Factors

SoCalGas and SDG&E reviewed drawings and records, contacted internal planning groups, communicated with external stakeholders, conducted survey activity, and completed a pre-design site walk. Key factors that influenced the engineering and design of the Project are as follows:

1. Engineering Assessment: During the site evaluation, the Project Team confirmed the existing technology. There were no items of note that affected the design.
2. Valve Details: The existing valve was a manually operated Class 600 ball valve that the Project Team reused.
3. Actuator Details: There was no preexisting actuator, the Project Team installed a new actuator.
4. Customer Impact: The Project Team did not anticipate service disruptions to customers.
5. Community Impact: The Project Team informed the residents of the planned activities prior to construction. The Project Team took precautions to minimize the impact of construction to the community.
6. Substructures: The Project Team identified an existing launcher for Line 1020 next to the project site in a vault.

Pipeline Safety Enhancement Plan Final Report
Line 1020 Valve Enhancement Project

7. Environmental: The Project Team did not identify any notable environmental concerns at the site. An environmental monitor performed spot checks during construction.
8. Permit Restrictions: There were no special permits or permit restrictions for this project site.
9. Land Use: The local electric utility has a facility next to the Project Site. The Project Team obtained a Temporary Right of Entry to utilize that space as a laydown yard.
10. Traffic Control: The Project Team did not identify any traffic control needs at the site.

Pipeline Safety Enhancement Plan Final Report Line 1020 Valve Enhancement Project

Figure 2: Line 1020 Valve Enhancement Project Schematic

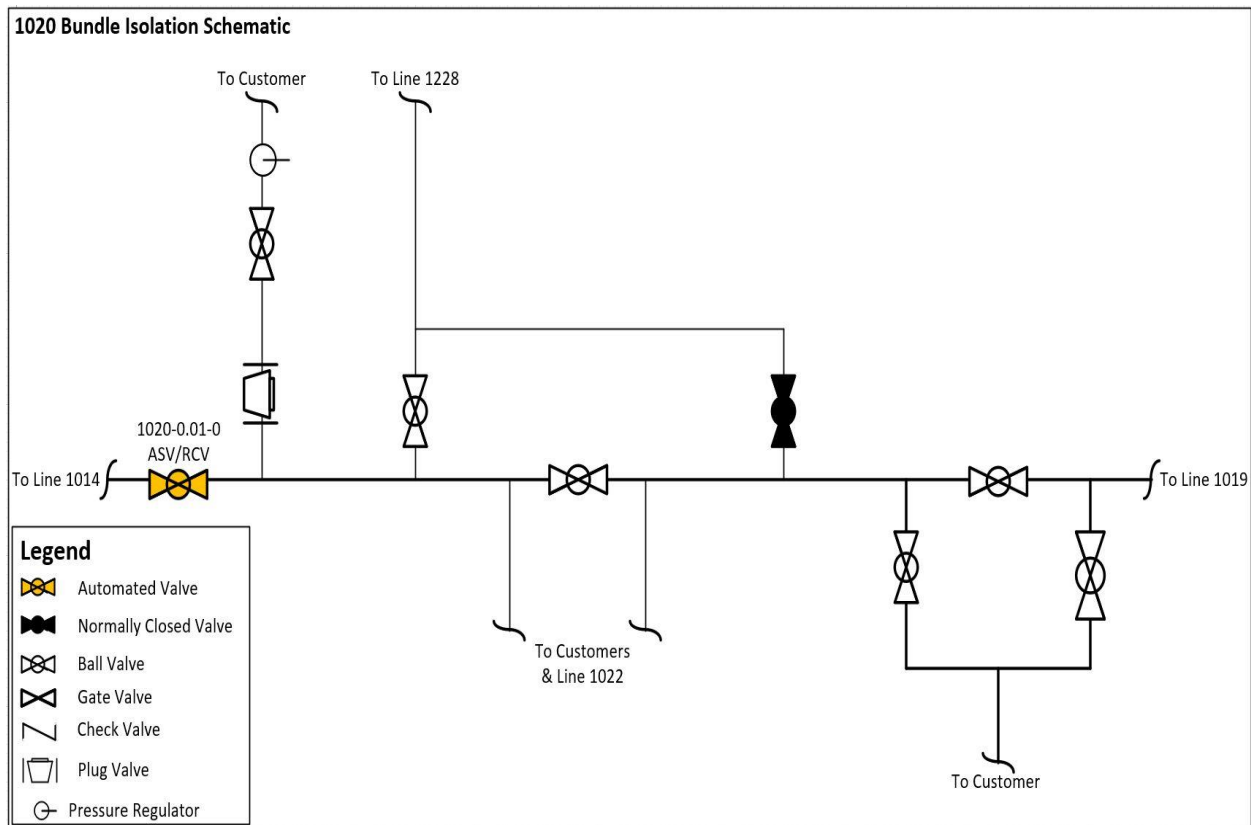

Pipeline Safety Enhancement Plan Final Report
Line 1020 Valve Enhancement Project

D. Scope Changes

Through engineering, design, and planning activities, SoCalGas and SDG&E determined that changes in scope were appropriate to enhance the design of the Project and address engineering factors. As a result, the preliminary cost estimate does not fully reflect the final scope. SoCalGas and SDG&E had planned to install a check valve as part of this project. The Project team descope the installation of the check valve from this project and the Operating District incorporated it into the design of the new meter set assembly to be installed at a later date.

Pipeline Safety Enhancement Plan Final Report
Line 1020 Valve Enhancement Project

III. CONSTRUCTION

A. Construction Contractor Selection

The Project Team prepared an initial cost estimate based on the preliminary design. Following completion of the engineering, design, and planning activities described above, the Project Team directed the Performance Partner (Mechanical Construction Contractor) and Alliance Partner (Electrical Contractor) to prepare cost estimates based on a more detailed engineering design package, that included the updated design described in the discussion of notable changes in scope above.

1. SoCalGas and SDG&E's Preliminary Mechanical Construction Contractor Estimate (confidential): SoCalGas and SDG&E's preliminary cost estimate for construction was [REDACTED].
2. Mechanical Construction Contractor's Target Price Estimate (confidential): The Mechanical Construction Contractor's cost estimate was [REDACTED], which was [REDACTED] than SoCalGas and SDG&E's preliminary cost estimate for construction.
3. SoCalGas and SDG&E's Preliminary Electrical Contractor Estimate (confidential): SoCalGas and SDG&E's preliminary cost estimate for construction was [REDACTED].
4. Electrical Contractor's Estimate (confidential): The Electrical Contractor's estimate was [REDACTED], which was [REDACTED] than SoCalGas and SDG&E's preliminary cost estimate.

Pipeline Safety Enhancement Plan Final Report
Line 1020 Valve Enhancement Project

B. Construction Schedule

Table 3: Construction Timeline

Construction Start Date	03/23/2015
Construction Completion Date	03/30/2016
Days on Site	38 days
Commissioning Date	06/08/2016

The Project Team completed all construction activities as soon as practicable prior to commissioning. SoCalGas and SDG&E’s finalization of commissioning activities is dependent on electrical utility connections, and system and/or resource availability.

C. Changes During Construction

The conditions summarized below were encountered during construction. Activities to address or mitigate these conditions resulted in approximately \$92,000 in change orders.

1. Field Design Change:
 - a. Upon excavation, the Project Team determined that the existing valve would not interface with the new actuator. The Project Team ordered a new actuator and directed the Mechanical Construction Contractor to reattach the preexisting gearbox and prepare the site for demobilization until the new actuator was available.

Pipeline Safety Enhancement Plan Final Report
Line 1020 Valve Enhancement Project

- b. SoCalGas and SDG&E requested that the Mechanical Construction Contractor construct a platform over the excavation to provide access to the preexisting gearbox. The Project Team also requested that the Mechanical Construction Contractor leave the fencing and shoring in place during the planned construction shut down.
 - c. SoCalGas and SDG&E requested that the Mechanical Construction Contractor replace the existing operator and backfill open trenches prior to demobilization.
2. Weather: SoCalGas and SDG&E Gas Control requested a temporary work hold on Line 1020 due to cold weather and system demands. The Mechanical Construction Contractor was on standby for three days.
3. Additional Support: SoCalGas and SDG&E requested the Mechanical Construction Contractor to assist with the installation of the pin-off tees. The Mechanical Construction Contractor also assisted with the installation of the actuator.

Pipeline Safety Enhancement Plan Final Report
Line 1020 Valve Enhancement Project

Figure 3: Line 1020 Valve Enhancement Project – Excavation and Existing Valve

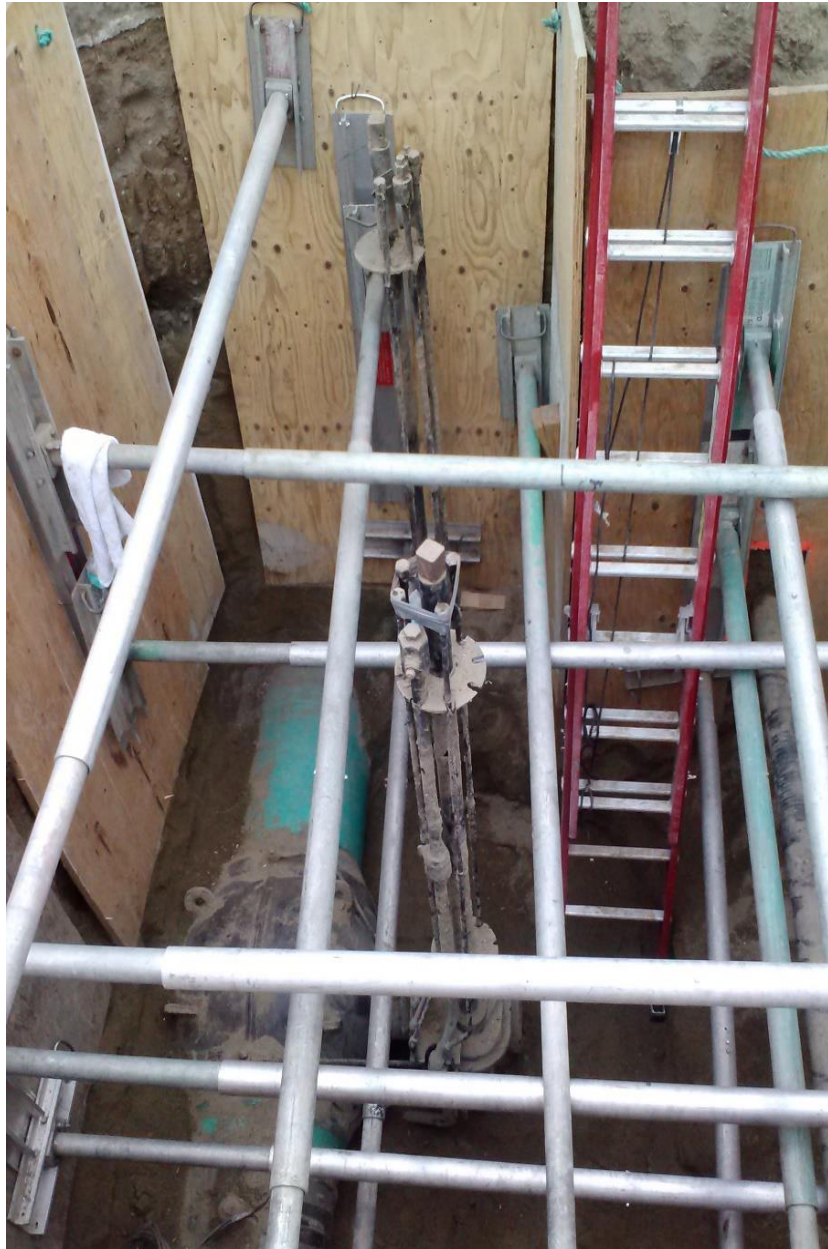

Pipeline Safety Enhancement Plan Final Report
Line 1020 Valve Enhancement Project

D. Commissioning and Site Restoration

Commissioning activities included site restoration, final inspections, and placement of the valve back into service. During this stage, SoCalGas and SDG&E successfully performed site acceptance testing and conducted point-to-point verification with SoCalGas Gas Control personnel for the newly-automated valve. SoCalGas and SDG&E trained Field Operations personnel on the proper use and operation of the new equipment. Closeout activities included development of final drawings, the reconciliation package, and updates to company recordkeeping systems to reflect the completed scope of work. The site was commissioned on June 8, 2016 as summarized in Table 3.

Pipeline Safety Enhancement Plan Final Report
Line 1020 Valve Enhancement Project

IV. PROJECT COSTS

A. Cost Avoidance Actions

SoCalGas and SDG&E exercised due diligence in the design, planning, and construction activities for this project to minimize or avoid costs when prudent to do so. As discussed above, the Project Team reviewed existing records, communicated with external stakeholders, and conducted a pre-design site walk to incorporate the known site conditions in the project plan and design.

B. Cost Estimates

Based on the preliminary design, once the preliminary project scope was confirmed and engineering, design, and planning activities were underway, SoCalGas and SDG&E prepared an estimate of the Direct Costs of the Project in the amount of \$1,148,650. This estimate was prepared in June of 2014, using the “Stage 3 SCG Valve Estimate Template Rev 0” estimating tool, the most current version of the PSEP Estimate Template at the time. The Project Team considered the conditions known at the time to prepare the preliminary Direct Cost estimate. This estimate reflects the projected Labor, Material and Services costs anticipated to be incurred to execute the Project, based on initial design plans.

SoCalGas and SDG&E estimated Indirect Costs of the Project based on the estimated Direct Costs and other project-related variables.

Pipeline Safety Enhancement Plan Final Report
Line 1020 Valve Enhancement Project

C. Actual Direct and Indirect Costs

Actual Direct Costs reflect the Labor, Material, and Services costs incurred to execute the Project. Actual Indirect Costs reflect costs for incremental overhead loaders in accordance with Company overhead allocation policies. The total loaded cost of the Project is \$1,664,184.

Table 4: Estimated and Actual Direct Costs and Variances

Direct Costs (\$)	Estimate	Actuals	Delta Over/(Under)
Company Labor	89,850	63,628	(26,222)
Materials	177,409	144,437	(32,972)
Mechanical Construction Contractor	321,613	261,532	(60,081)
Electrical Contractor	98,175	129,914	31,739
Construction Management & Support	81,544	89,742	8,198
Environmental	44,990	33,564	(11,426)
Engineering & Design	201,659	405,331	203,672
Project Management & Services	10,358	95,492	85,134
ROW & Permits	1,650	10,294	8,644
GMA	121,402	160,161	38,759
Total Direct Costs	1,148,650	1,394,095	245,445

Table 5: Estimated and Actual Indirect Costs, Total Costs, and Variances

Indirect Costs/Total Costs (\$)	Estimate	Actuals	Delta Over/(Under)
Overheads	179,036	168,966	(10,070)
AFUDC	37,591	89,842	52,251
Property Taxes	7,220	11,281	4,061
Total Indirect Costs	223,847	270,089	46,242
Total Direct Costs	1,148,650	1,394,095	245,445
Total Loaded Costs	1,372,497	1,664,184	291,687

Pipeline Safety Enhancement Plan Final Report
Line 1020 Valve Enhancement Project

V. CONCLUSION

SoCalGas and SDG&E enhanced the safety of their integrated natural gas system by prudently executing the Line 1020 Valve Enhancement Project. Through this Valve Enhancement Project, SoCalGas and SDG&E successfully automated one mainline valve to achieve the objective of enabling rapid system isolation in the City of Lakewood. The total loaded cost of the Project is \$1,664,184.

SoCalGas and SDG&E executed this project prudently through installing a new actuator in a vault, and by responding to unanticipated field changes, for example the Project Team worked with the local electric utility to reroute the conduit to avoid a storm culvert without adding additional cost to the project.

SoCalGas and SDG&E engaged in prudent cost avoidance efforts to complete this safety enhancement at a reasonable cost by engaging in reasonable efforts to promote competitive and market-based rates for contractor services and materials, and by using a reasonable amount of company and contractor resources to complete the safety enhancement work as soon as practicable.

End of Line 1020 Valve Enhancement Project Final Report

Pipeline Safety Enhancement Plan Final Report
Line 1600 Valve Enhancement Project Bundle**I. LINE 1600 VALVE ENHANCEMENT PROJECT BUNDLE**

A. Background and Summary

This report describes the activities associated with the Line 1600 Valve Enhancement Project Bundle that consists of valve enhancements made to 16 existing mainline valves (MLVs) throughout San Diego County. Through this project, SoCalGas and SDG&E enhanced the capabilities of 16 MLVs to enable rapid transmission system isolation to a portion of Lines 1600, 1601, and 2010. SoCalGas and SDG&E upgraded the existing automation equipment to be compatible with PSEP linebreak technology. SoCalGas and SDG&E installed new solenoid valves, new pressure transducers, new solenoid valves, and two new flow meters. The total loaded project cost is \$706,621.

The Line 1600 Valve Enhancement Project Bundle sites are located in urban and rural areas in San Diego County and are separated into 15 different sites. All construction activities were performed within existing SoCalGas and SDG&E easements.

Pipeline Safety Enhancement Plan Final Report
Line 1600 Valve Enhancement Project Bundle

Table 1: General Project Information

Line 1600 Valve Enhancement Project Bundle			
Site	All valves on 1600	All valves on 1601	Kearny Villa Station
Location	Various Cities	Various Cities	Miramar
Days on Site	2-3 days (typical)	2-3 days (typical)	TBD
Construction Start	12/22/2014	12/22/2014	12/22/2014
Construction Finish	07/27/2015	07/27/2015	07/27/2015
Commissioning Date ¹	N/A	N/A	12/13/2016
Valve Upgrades			
Valve Number	1601 through 1610	1620 through 1624	2011
Valve Type	Existing	Existing	Existing
Actuator	Existing	Existing	Existing
Actuator Above-/Below-Grade	9 Above-Grade 1 Below-Grade	1 Above-Grade 4 Below-Grade	Above-Grade
ASV	Yes	Yes	Yes
RCV	Yes	Yes	Yes
Site Upgrades			
Vault	Various	Various	Various
Power	Existing	Existing	Existing
Communication	Existing	Existing	Existing
SCADA Panel	Existing	Existing	Existing
Equipment Shelter	Existing	Existing	Existing
Fencing/Wall	Various	Various	Various
Project Costs (\$)	Capital	O&M	Total
Loaded Project Costs	706,621	-	706,621
Disallowed Costs	-	-	-

¹ Commissioning Date for flowmeters only. Commissioning was not required for modifications to the existing automation equipment.

Pipeline Safety Enhancement Plan Final Report
Line 1600 Valve Enhancement Project Bundle

B. Maps and Images

Figure 1: Satellite Image of Line 1600 Valve Enhancement Project Bundle: Overview

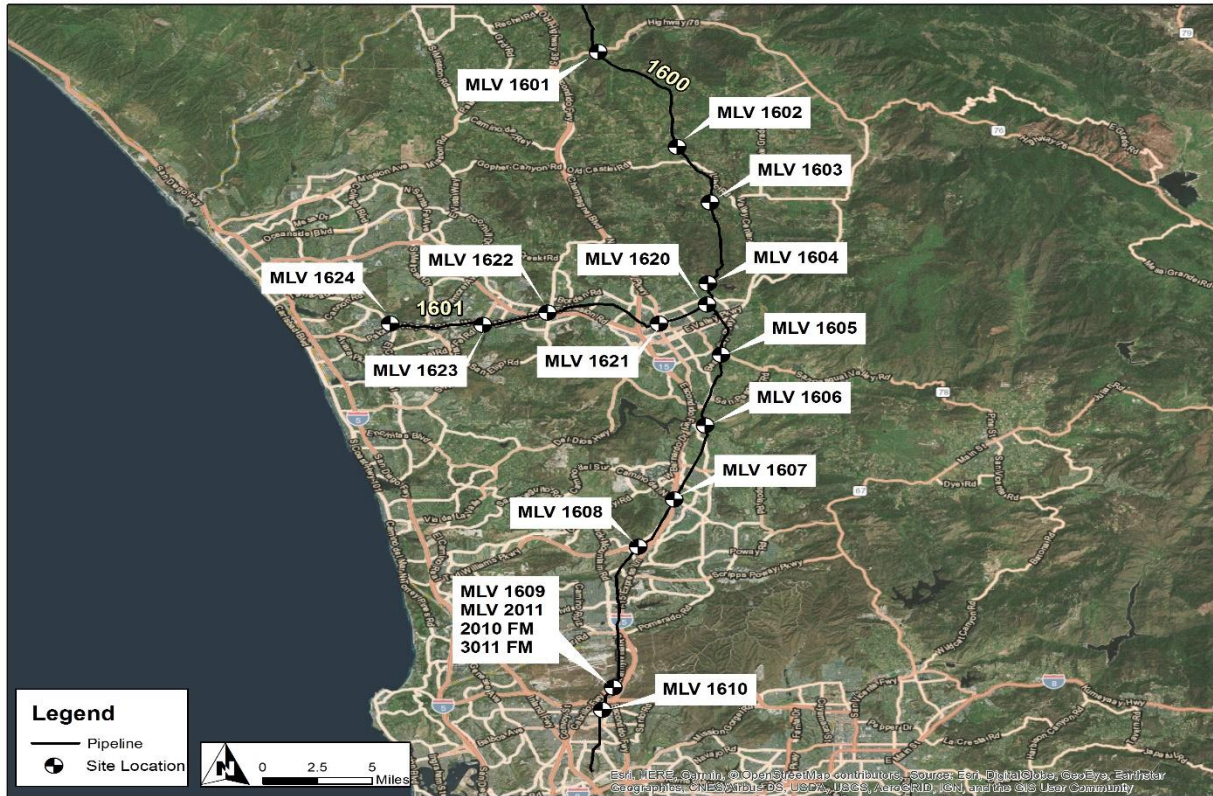

Pipeline Safety Enhancement Plan Final Report Line 1600 Valve Enhancement Project Bundle

Figure 2: Satellite Image of Valve 1601



Pipeline Safety Enhancement Plan Final Report Line 1600 Valve Enhancement Project Bundle

Figure 3: Satellite Image of Valve 1602



Pipeline Safety Enhancement Plan Final Report
Line 1600 Valve Enhancement Project Bundle

Figure 4: Satellite Image of Valve 1603



Pipeline Safety Enhancement Plan Final Report
Line 1600 Valve Enhancement Project Bundle

Figure 5: Satellite Image of Valve 1604



Pipeline Safety Enhancement Plan Final Report Line 1600 Valve Enhancement Project Bundle

Figure 6: Satellite Image of Valve 1605



Pipeline Safety Enhancement Plan Final Report Line 1600 Valve Enhancement Project Bundle

Figure 7: Satellite Image of Valve 1606

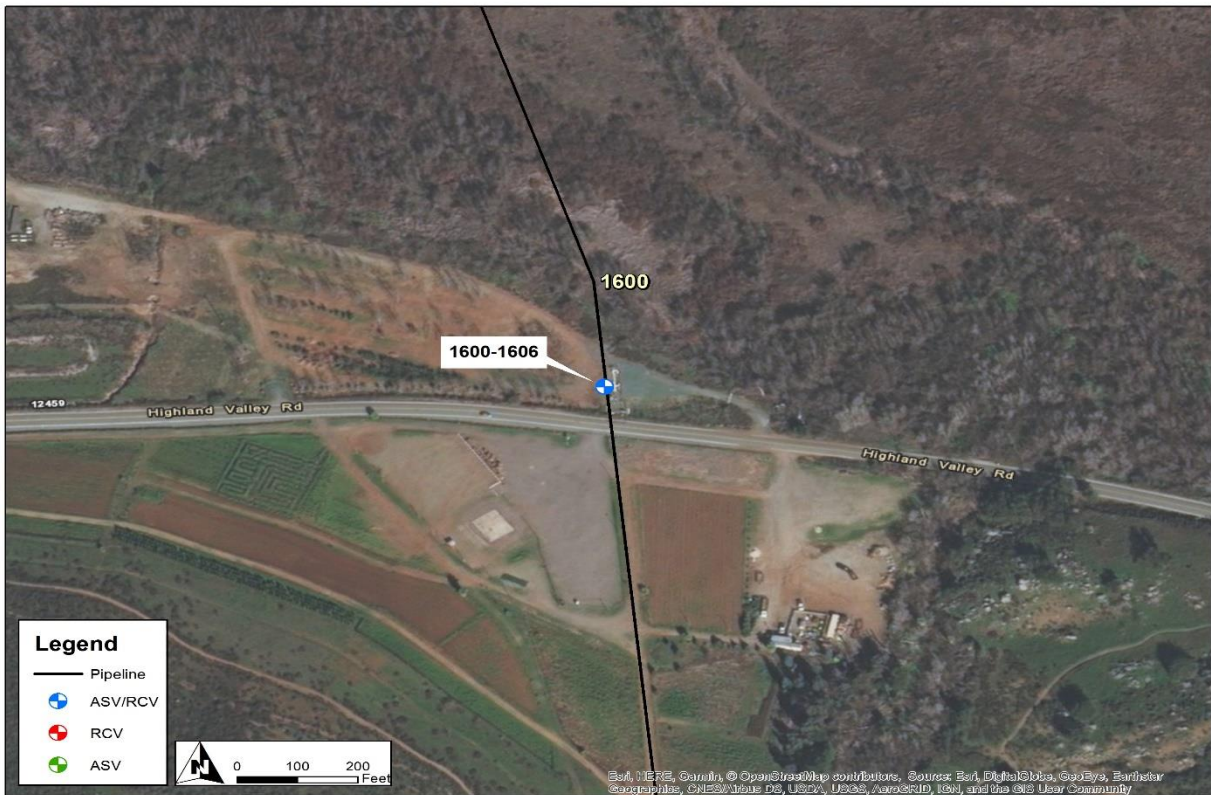

Pipeline Safety Enhancement Plan Final Report Line 1600 Valve Enhancement Project Bundle

Figure 8: Satellite Image of Valve 1607

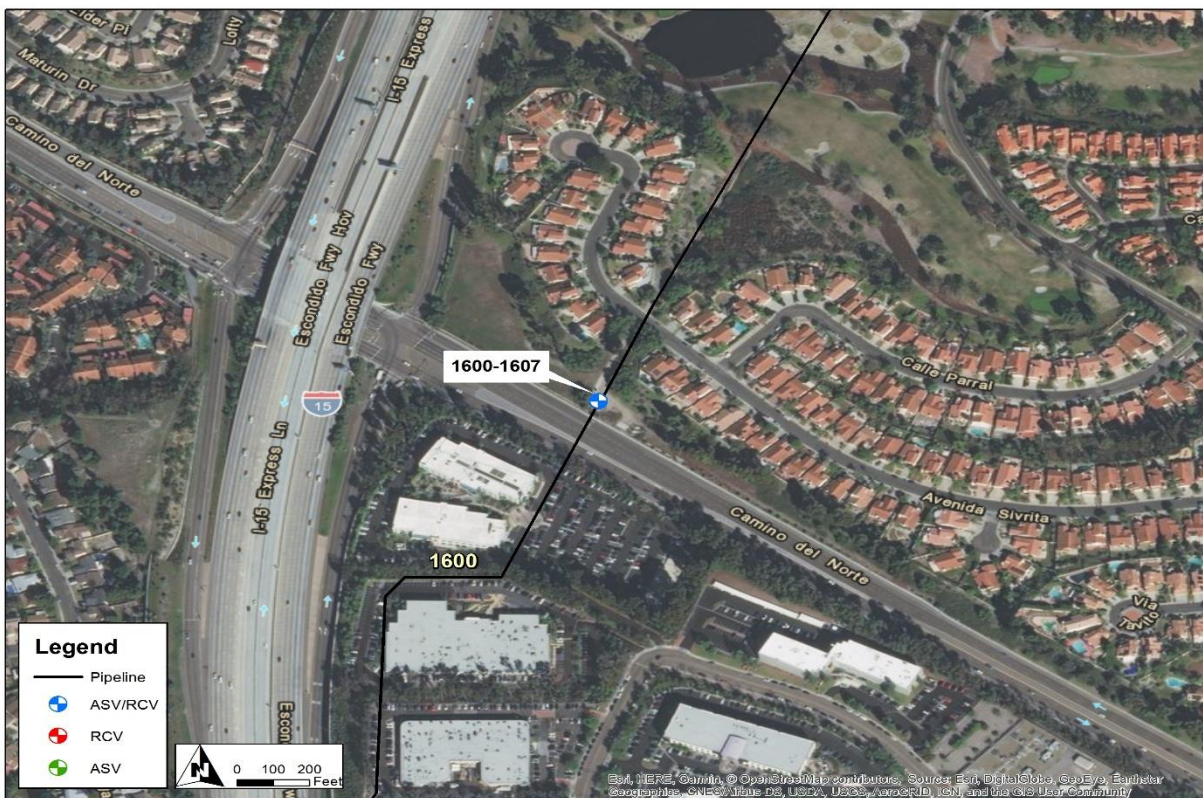

Pipeline Safety Enhancement Plan Final Report Line 1600 Valve Enhancement Project Bundle

Figure 9: Satellite Image of Valve 1608



Pipeline Safety Enhancement Plan Final Report
Line 1600 Valve Enhancement Project Bundle

Figure 10: Satellite Image of Kearny Villa Station (containing Valve 1609, 2011, and Line 2010 and Line 3011 Flow Meters)

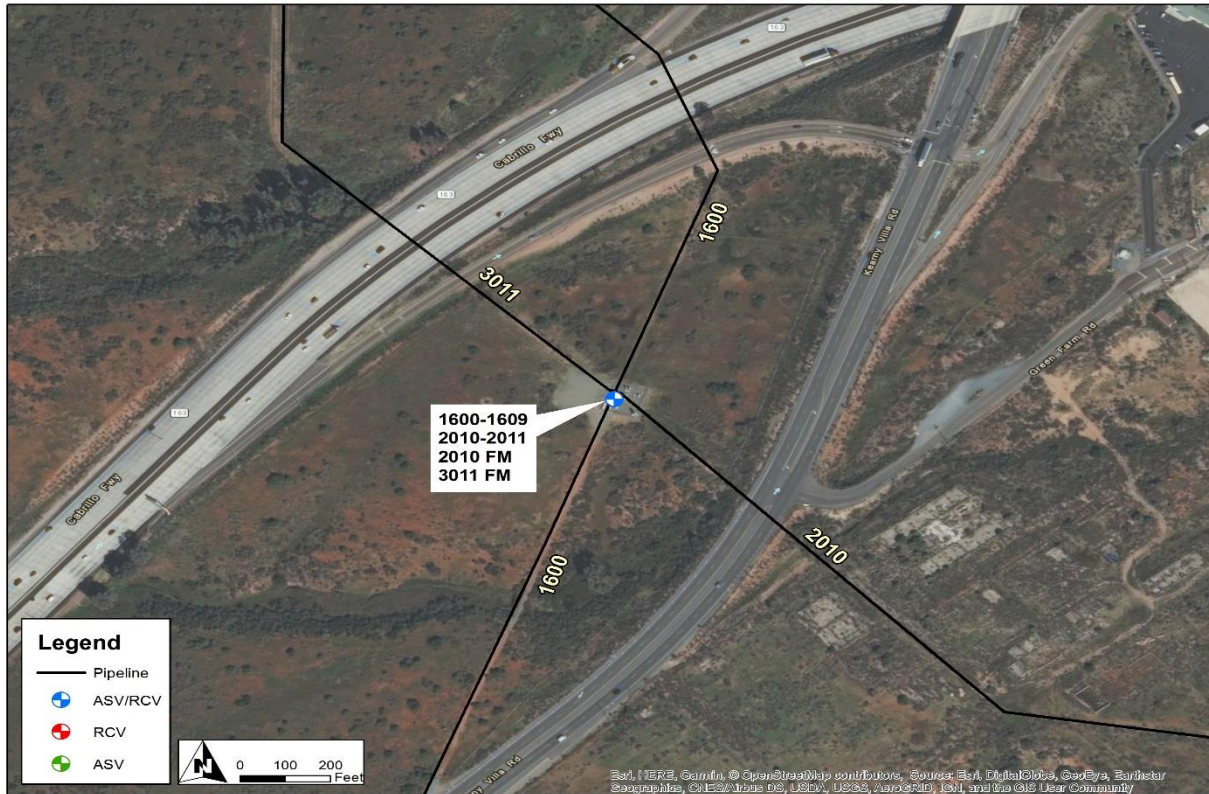

Pipeline Safety Enhancement Plan Final Report
Line 1600 Valve Enhancement Project Bundle

Figure 11: Satellite Image of Valve 1610

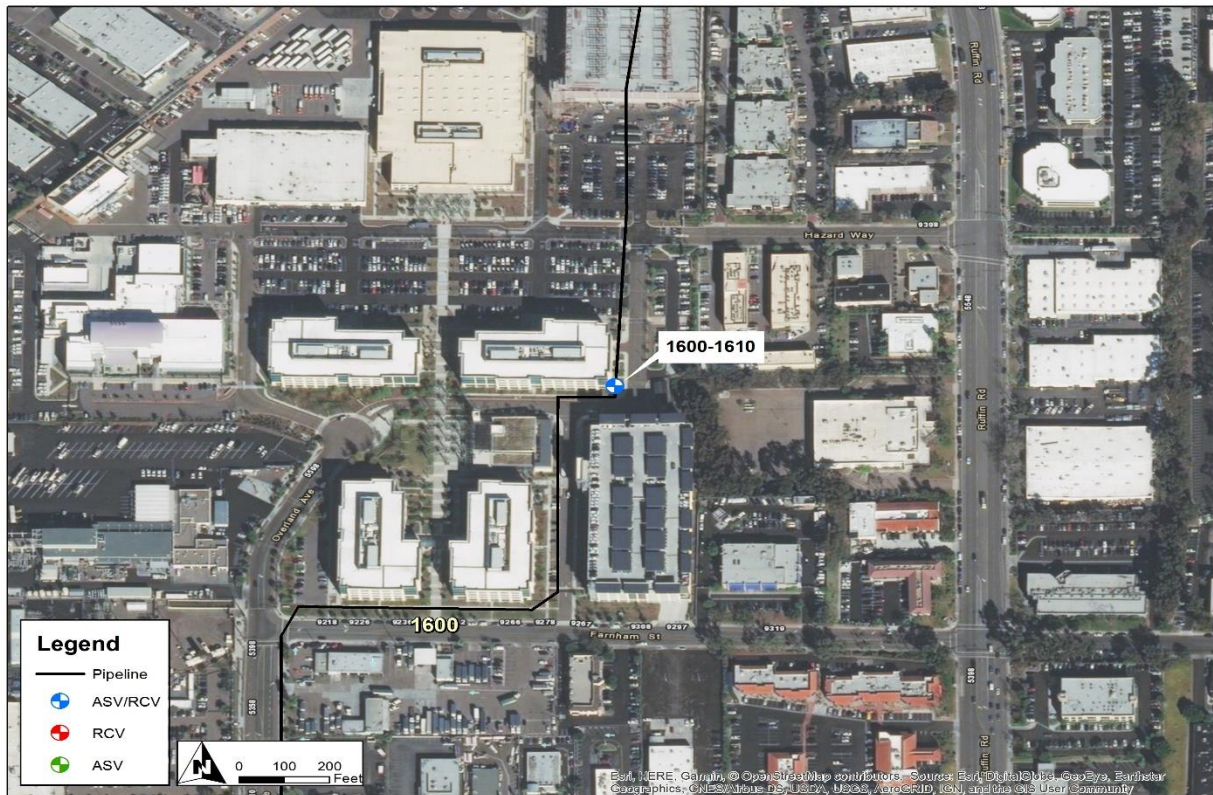

Pipeline Safety Enhancement Plan Final Report Line 1600 Valve Enhancement Project Bundle

Figure 12: Satellite Image of Valve 1620



Pipeline Safety Enhancement Plan Final Report Line 1600 Valve Enhancement Project Bundle

Figure 13: Satellite Image of Valve 1621



Pipeline Safety Enhancement Plan Final Report Line 1600 Valve Enhancement Project Bundle

Figure 14: Satellite Image of Valve 1622



Pipeline Safety Enhancement Plan Final Report Line 1600 Valve Enhancement Project Bundle

Figure 15: Satellite Image of Valve 1623

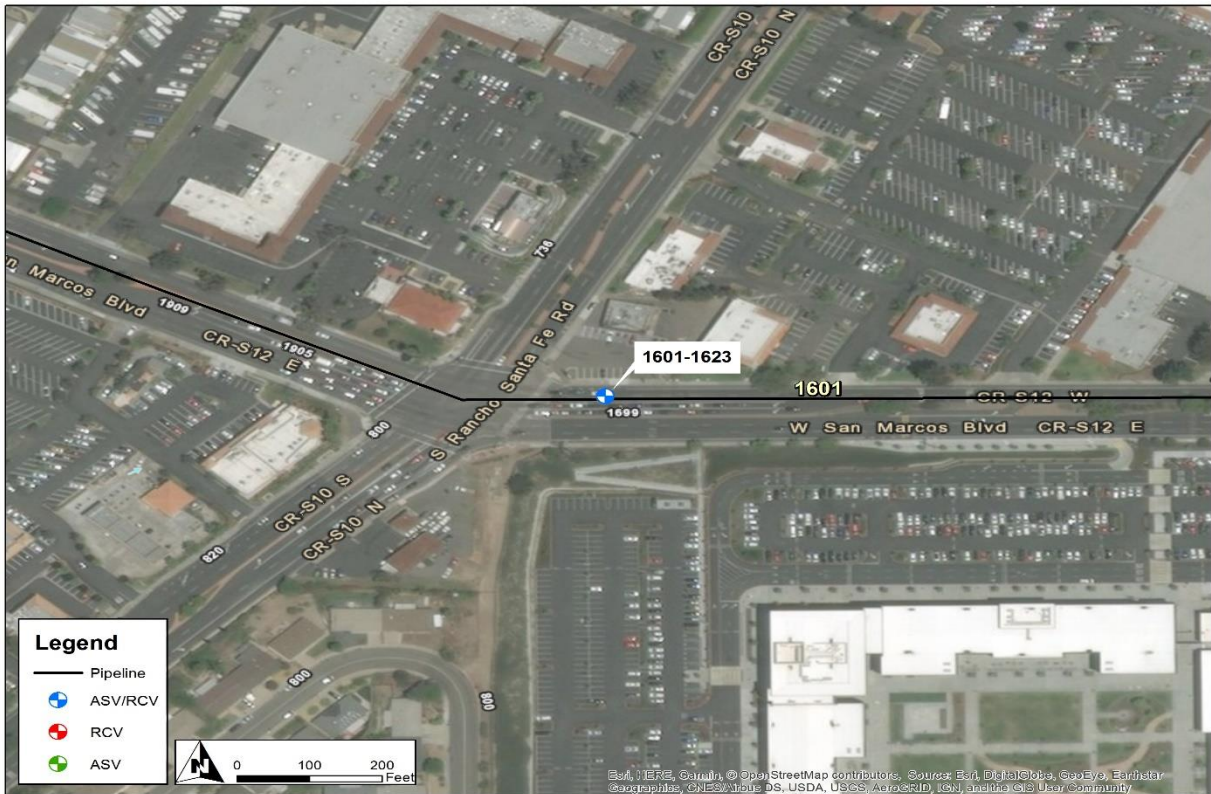

Pipeline Safety Enhancement Plan Final Report Line 1600 Valve Enhancement Project Bundle

Figure 16: Satellite Image of Valve 1624



Pipeline Safety Enhancement Plan Final Report
Line 1600 Valve Enhancement Project Bundle

II. ENGINEERING, DESIGN, AND PLANNING

A. Project Scope

SoCalGas and SDG&E presented a conceptual project scope in workpapers supporting the Valve Enhancement Plan² in the 2011 filing. This conceptual scope did not include this project. SoCalGas and SDG&E reviewed available information and performed a detailed system flow analysis that identified these valves as candidates for enhancement to provide the planned isolation. The final project scope is summarized in Table 2 below.

1. 2011 PSEP Filing: SoCalGas and SDG&E did not previously identify these valves for automation to achieve the objective of rapid system isolation.
2. Updated Scope: SoCalGas and SDG&E identified 16 valves for automation, as well as the installation of two flow meters. Together, the automation of these 16 valves and the installation of these two flow meters enable rapid isolation, achieving the Valve Enhancement Plan objectives.
3. Engineering, Design, and Constructability: The Project Team evaluated the existing valve automation equipment and determined that the installation of new solenoid valves, new pressure transducers, and new pressure transmitters was all that was necessary to upgrade the existing automation equipment to conform with PSEP design standards.

² See Workpapers supporting Amended Pipeline Safety Enhancement Plan (PSEP) of SoCalGas and SDG&E, submitted on December 2, 2011, at WP-IX-2-14 through WP-IX-2-25 (A.11-11-002 Exh. # SCG-32).

Pipeline Safety Enhancement Plan Final Report
Line 1600 Valve Enhancement Project Bundle

4. Final Project Scope: The final project scope consists of upgrades made to existing automation equipment for 16 valves that included the installation of solenoid valves, pressure transducers, and pressure transmitters in the existing automation equipment. Two flow meters were also installed on Lines 2010 and 3011.

Table 2: Final Project Scope

Final Project Scope					
Line	Mile ³	Valve #	Valve Size (<i>confidential</i>)	Installation Type	Function
1600		1601	██████	COMM	ASV/RCV
1600		1602	██████	COMM	ASV/RCV
1600		1603	██████	COMM	ASV/RCV
1600		1604	██████	COMM	ASV/RCV
1600		1605	██████	COMM	ASV/RCV
1600		1606	██████	COMM	ASV/RCV
1600		1607	██████	COMM	ASV/RCV
1600		1608	██████	COMM	ASV/RCV
1600		1609	██████	COMM	ASV/RCV
1600		1610	██████	COMM	ASV/RCV
1601		1620	██████	COMM	ASV/RCV
1601		1621	██████	COMM	ASV/RCV
1601		1622	██████	COMM	ASV/RCV
1601		1623	██████	COMM	ASV/RCV
1601		1624	██████	COMM	ASV/RCV
2010		2011	██████	COMM	ASV/RCV
2010		FM	██████	FM	FLOWMETER
3011		FM	██████	FM	FLOWMETER

³ Valve naming convention at SDG&E does not include milepoints.

Pipeline Safety Enhancement Plan Final Report
Line 1600 Valve Enhancement Project Bundle

B. Site Evaluation and Planning

Key factors that influenced the engineering and design of this project at all sites are as follows:

All Sites:

1. Site Description: The Project Sites were located in urban and rural areas in San Diego County.
2. Land Issues: The Project Team determined that all construction activities could be completed within existing easements.
3. DOT Class: The Project sites are within Class 1 and Class 3 locations. SoCalGas and SDG&E selected the valves in Class 1 locations for automation to isolate HCA locations upstream and downstream of each valve.
4. Power Source:
 - a. The sites had existing power equipment.
 - b. The Kearny Villa Station site had existing power equipment. The Project Team expanded the power equipment to accommodate the increased loads from the upgraded automation equipment and the new flow meters.
5. Communication Technology:
 - a. The sites had existing communications equipment.
 - b. The Kearny Villa Station site had existing communications. The Project Team upgraded the existing communications equipment so that it was compatible with the PSEP technology.

Pipeline Safety Enhancement Plan Final Report
Line 1600 Valve Enhancement Project Bundle

C. Engineering, Design, and Planning Factors

SoCalGas and SDG&E reviewed drawings and records, and contacted internal planning groups. Key factors that influenced the engineering and design of the Project are as follows:

All Sites:

1. Engineering Assessment: The Project Team confirmed the preexisting technology and verified that the existing automation equipment did not meet the PSEP Valve Enhancement standard. The Project Team determined that the installation of new solenoid valves, new pressure transducers and new pressure transmitters would monitor real-time flow measurements and result in the existing automation equipment meeting the PSEP Valve Enhancement Standard.
2. Valve Details: The existing valves were actuated ball valves that the Project Team reused.
3. Actuator Details: All valves had existing actuators that the Project Team reused.
4. Customer Impact: The Project Team did not anticipate service disruptions to customers.
5. Community Impact: The Project Team did not anticipate any notable impacts to the community from this project.
6. Substructures: The Project Team did not identify any existing substructures that affected the design and engineering at this site.
7. Environmental: The Project Team did not identify any notable environmental concerns at the site. An environmental monitor performed spot checks during construction.

Pipeline Safety Enhancement Plan Final Report Line 1600 Valve Enhancement Project Bundle

8. Permit Restrictions: There were no special permits or permit restrictions for this project site.
9. Land Use: The Project Team performed all work within existing SDG&E easements.
10. Traffic Control: The Project Team did not identify any traffic control needs at the site.

D. Scope Changes

Through engineering, design, and planning activities, SoCalGas and SDG&E determined that changes in scope were appropriate to enhance the design of the Project and address engineering factors. As a result, the preliminary cost estimate does not fully reflect the final scope. During construction, the Project Team identified MLV 2010-2011 as requiring upgrades to isolate Line 1600 from Line 2010. The Project Team determined that it was more cost effective to include the upgrades to the automation equipment with this bundle as opposed to performing the upgrades at a later date.

Pipeline Safety Enhancement Plan Final Report
Line 1600 Valve Enhancement Project Bundle

Figure 17: Line 1600 Valve Enhancement Project Bundle Schematic

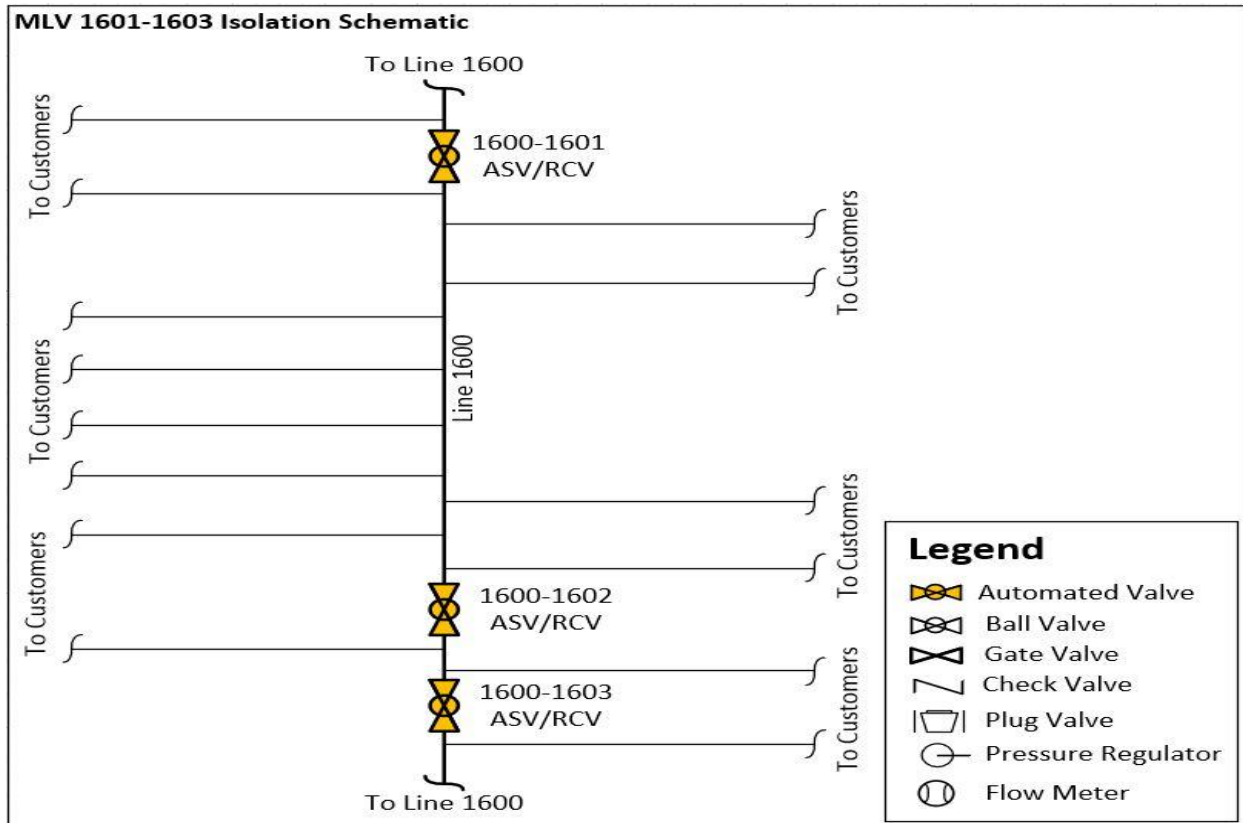

Pipeline Safety Enhancement Plan Final Report Line 1600 Valve Enhancement Project Bundle

Figure 18: Line 1600 Valve Enhancement Project Bundle Schematic

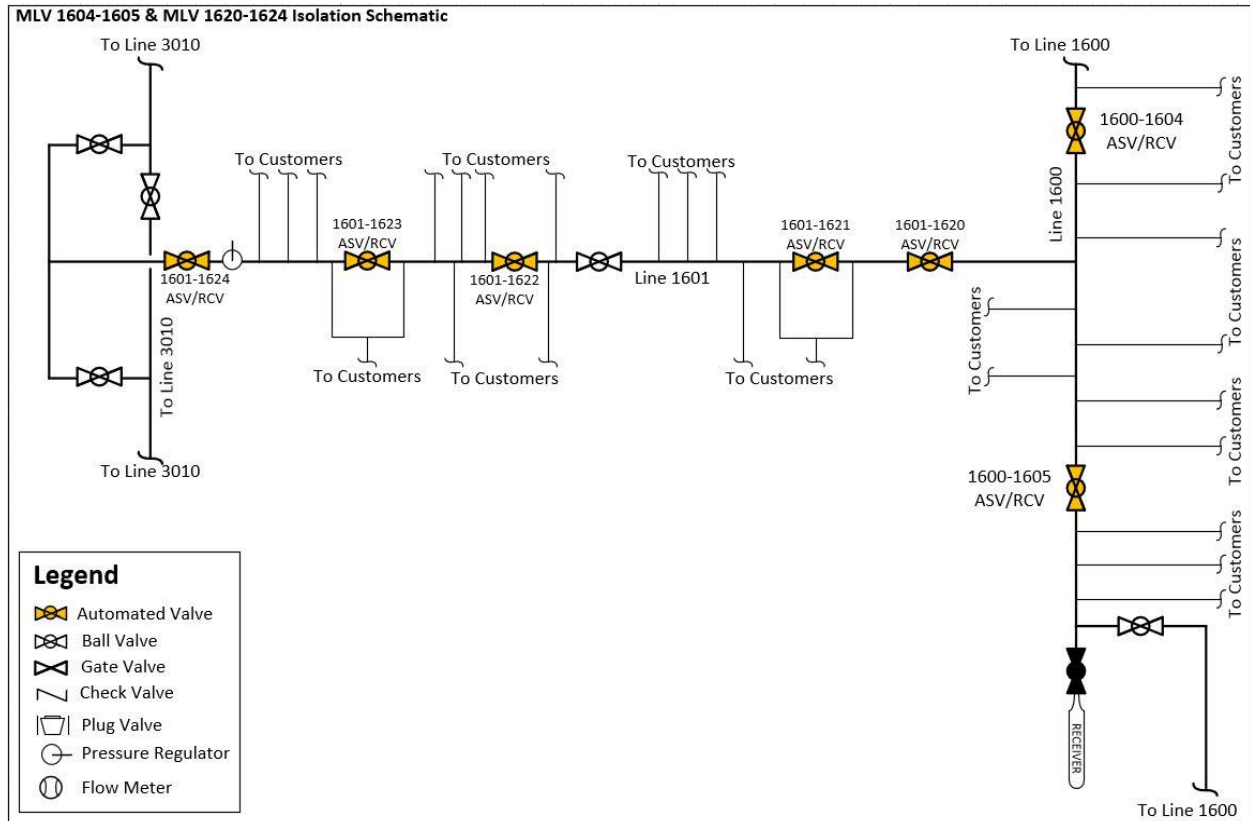

Pipeline Safety Enhancement Plan Final Report Line 1600 Valve Enhancement Project Bundle

Figure 19: Line 1600 Valve Enhancement Project Bundle Schematic

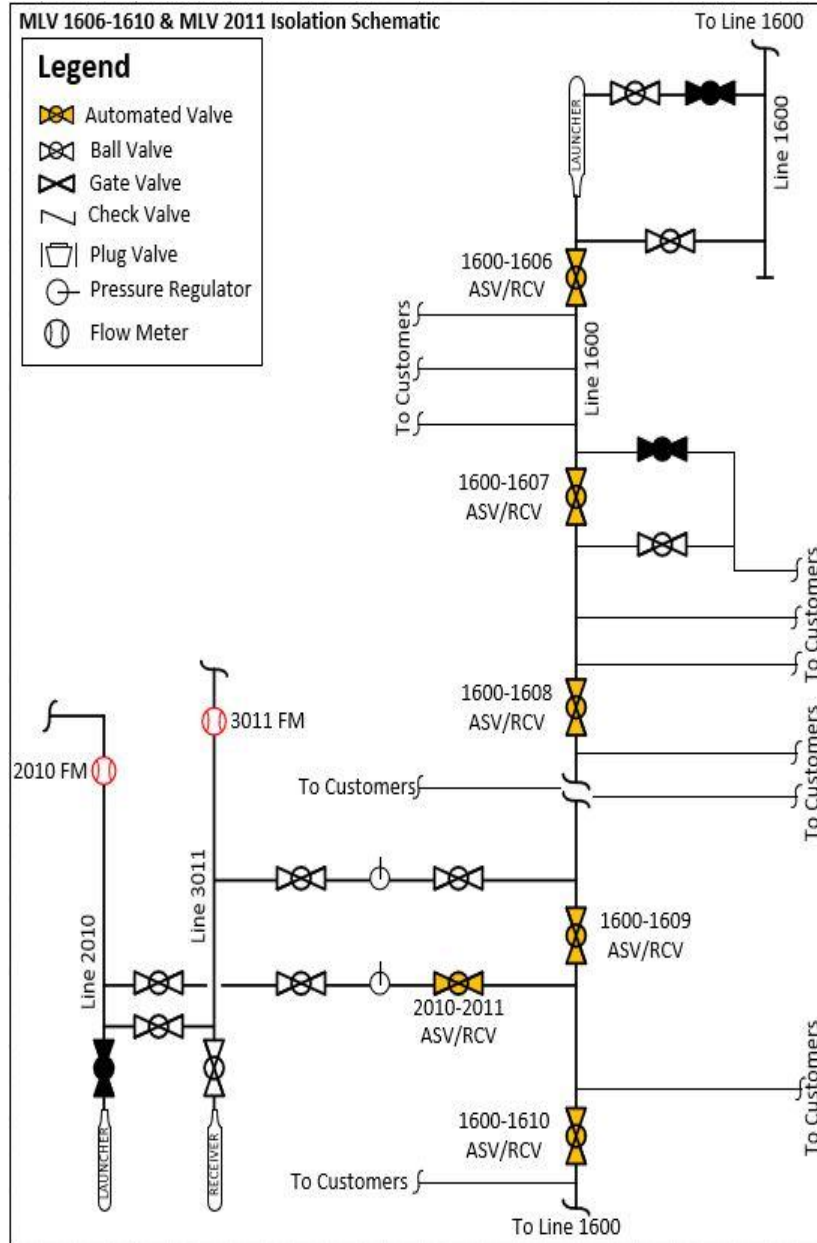

Pipeline Safety Enhancement Plan Final Report
Line 1600 Valve Enhancement Project Bundle

III. CONSTRUCTION

A. Construction Contractor Selection

The Project Team prepared an initial cost estimate based on the preliminary design. Following completion of the engineering, design, and planning activities described above, the Project Team directed the Alliance Partner (Electrical Contractor) to prepare cost estimates based on a more detailed engineering design package, that included the updated design described in the discussion of notable changes in scope above.

1. SoCalGas and SDG&E’s Preliminary Electrical Contractor Estimate (confidential): SoCalGas and SDG&E’s preliminary cost estimate for construction was [REDACTED].
2. Electrical Contractor’s Estimate (confidential): The Electrical Contractor’s estimate was [REDACTED], which was [REDACTED] than SoCalGas and SDG&E’s preliminary cost estimate.

B. Construction Schedule

Table 3: Construction Timeline

Construction Start Date	12/22/2014
Construction Completion Date	07/27/2015
Days on Site	88 days
Commissioning Date ⁴	12/13/2016

The Project Team completed all construction activities as soon as practicable prior to commissioning. SoCalGas and SDG&E’s finalization of commissioning activities is dependent on electrical utility connections, and system and/or resource availability.

⁴ Commissioning Date for flowmeters only. Commissioning not required for control valve modifications.

Pipeline Safety Enhancement Plan Final Report
Line 1600 Valve Enhancement Project Bundle

C. Changes During Construction

SoCalGas and SDG&E successfully mitigated conditions during construction in a manner that minimized potential impacts on project scope, cost, and schedule. As a result, these conditions did not result in any notable change orders.

Pipeline Safety Enhancement Plan Final Report Line 1600 Valve Enhancement Project Bundle

Figure 20: Linebreak Cabinet (typical)

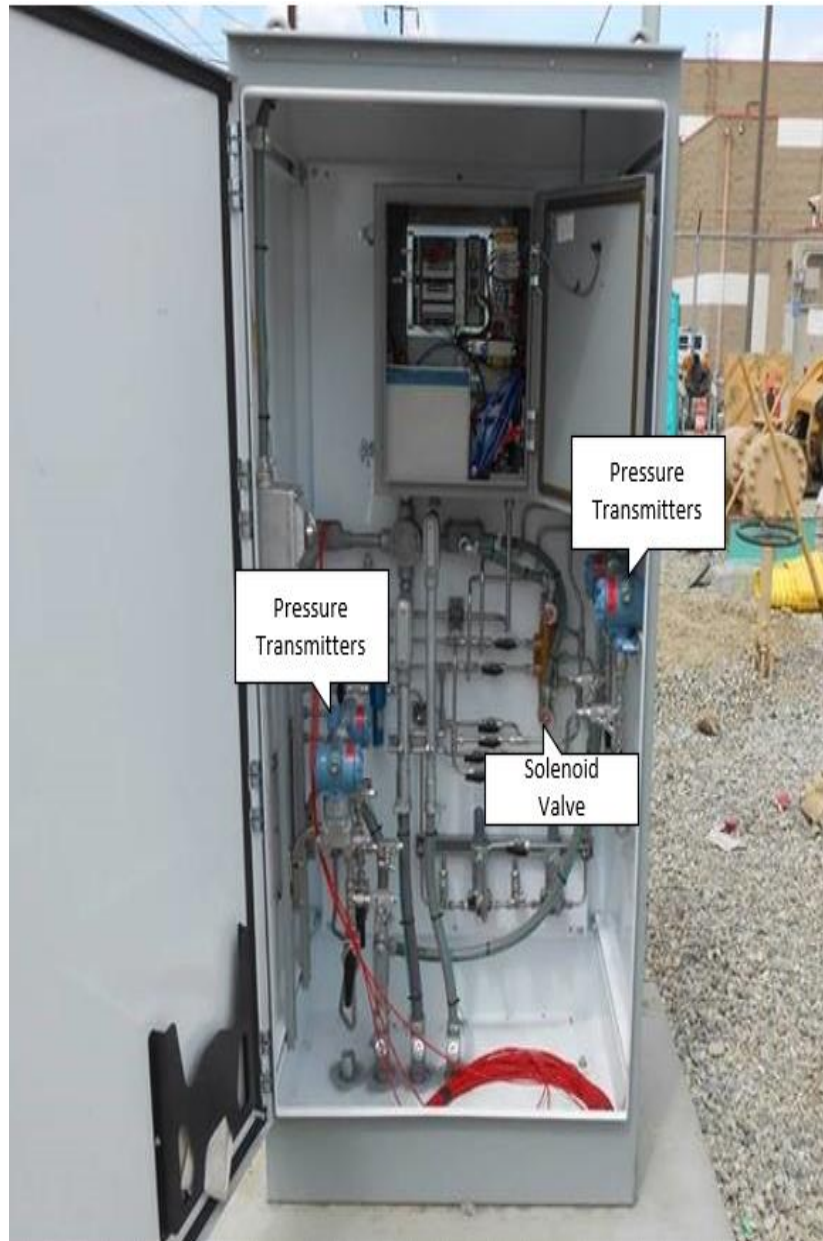

Pipeline Safety Enhancement Plan Final Report
Line 1600 Valve Enhancement Project Bundle

D. Commissioning and Site Restoration

Commissioning activities included site restoration, final inspections, and placement of the flow meters into service. SoCalGas and SDG&E successfully performed site acceptance testing and conducted point-to-point verification with San Diego Gas and Electric Gas Control personnel when original RCVs were installed. The newly-upgraded control modifications added ASV capabilities. SoCalGas and SDG&E trained Field Operations personnel on the proper use and operation of the new equipment. The flow meters were commissioned on December 13, 2016.

Pipeline Safety Enhancement Plan Final Report
Line 1600 Valve Enhancement Project Bundle

IV. PROJECT COSTS

A. Cost Avoidance Actions

SoCalGas and SDG&E exercised due diligence in the design, planning, and construction activities for this project to minimize or avoid costs when prudent to do so. As discussed above, the Project Team reviewed existing records, communicated with external stakeholders, and conducted a site walk to incorporate the known site conditions in the project plan and design. Specific examples of cost avoidance actions taken on this project were:

1. Planning and Coordination: This project bundled 15 sites in its initial scope. During construction, the Project Team identified a valve at one of the sites that required enhancement in order to provide proper isolation to Line 2010. SoCalGas and SDG&E determined that it was more cost effective to add this valve to the Valve 1600 project bundle instead of creating a separate future project.
2. Engineering and Design: The Project Team designed the installation of the flow meters on above-grade pipe to avoid vault installations.

B. Cost Estimates

Based on the preliminary design, once the preliminary project scope was confirmed and engineering, design, and planning activities were underway, SoCalGas and SDG&E prepared an estimate of the Direct Costs of the Project in the amount of \$809,594. The Project Team considered the conditions known at the time to prepare the preliminary Direct Cost estimate. This estimate reflects the projected Labor, Material, and Services costs anticipated to be incurred to execute the Project, based on initial design plans.

Pipeline Safety Enhancement Plan Final Report
Line 1600 Valve Enhancement Project Bundle

SoCalGas and SDG&E estimated Indirect Costs of the Project based on the estimated Direct Costs and other project-related variables.

C. Actual Direct and Indirect Costs

Actual Direct Costs reflect the Labor, Material, and Services costs incurred to execute the Project. Actual Indirect Costs reflect costs for incremental overhead loaders in accordance with Company overhead allocation policies. The total loaded cost of the Project is \$706,621.

Table 4: Estimated and Actual Direct Costs and Variances

Direct Costs (\$)	Estimate	Actuals	Delta Over/(Under)
Company Labor	137,234	81,238	(55,996)
Materials	227,647	115,925	(111,722)
Mechanical Construction Contractor	-	-	-
Electrical Contractor	146,871	166,330	19,459
Construction Management & Support	91,080	61,598	(29,482)
Environmental	-	18,549	18,549
Engineering & Design	83,471	35,553	(47,918)
Project Management & Services	52,622	18,016	(34,606)
ROW & Permits	-	-	-
GMA	70,669	21,245	(49,424)
Total Direct Costs	809,594	518,454	(291,140)

Pipeline Safety Enhancement Plan Final Report
Line 1600 Valve Enhancement Project Bundle

Table 5: Estimated and Actual Indirect Costs, Total Costs, and Variances

Indirect Costs/Total Costs (\$)	Estimate	Actuals	Delta Over/(Under)
Overheads	182,350	107,598	(74,752)
AFUDC	74,898	70,784	(4,114)
Property Taxes	-	9,785	9,785
Total Indirect Costs	257,248	188,167	(69,081)
Total Direct Costs	809,594	518,454	(291,140)
Total Loaded Costs	1,066,842	706,621	(360,221)

Pipeline Safety Enhancement Plan Final Report
Line 1600 Valve Enhancement Project Bundle

V. CONCLUSION

SoCalGas and SDG&E enhanced the safety of their integrated natural gas system by prudently executing the Line 1600 Valve Enhancement Project Bundle. Through this Valve Enhancement Project Bundle, SoCalGas and SDG&E successfully installed two new ultrasonic flow meters, power and communications equipment on Line 2010 and Line 3011, and upgraded 16 mainline valves to achieve the objective of enabling rapid system isolation in the Greater San Diego area. The total loaded cost of the Project is \$706,621.

SoCalGas and SDG&E executed this project prudently through bundling 16 valves and two flow meters at 15 valve sites.

SoCalGas and SDG&E engaged in prudent cost avoidance efforts to complete this safety enhancement project at a reasonable cost by planning and coordinating construction activities to minimize impacts to customers and the community.

End of Line 1600 Valve Enhancement Project Bundle Final Report

Pipeline Safety Enhancement Plan Final Report
Line 2000 Beaumont Riverside Valve Enhancement Project Bundle**I. LINE 2000 BEAUMONT RIVERSIDE VALVE ENHANCEMENT PROJECT
BUNDLE**

A. Background and Summary

This report describes the activities associated with the Line 2000 Beaumont Riverside Valve Enhancement Project Bundle that consists of valve enhancements made to three existing mainline valves (MLVs) in the Cities of Beaumont, Riverside, and Corona in Riverside County. Through this project, SoCalGas and SDG&E enhanced the capabilities of three MLVs to enable rapid transmission system isolation to a portion of Line 2000. SoCalGas and SDG&E installed new power equipment, new communications equipment, and necessary automation equipment at the sites. The total loaded project cost is \$2,786,310.

The valves comprising the Line 2000 Beaumont Riverside Bundle are in developed areas and are separated into three project sites. The MLV 14 site is an existing SoCalGas facility in a commercial and industrial area in the City of Beaumont, the MLV 17 site is an existing SoCalGas facility in a commercial area in the City of Riverside, and the MLV 20 site is located in a commercial area in the City of Corona.

Pipeline Safety Enhancement Plan Final Report
Line 2000 Beaumont Riverside Valve Enhancement Project Bundle

Table 1: General Project Information

Line 2000 Beaumont Riverside Valve Enhancement Project Bundle			
Site	MLV 14	MLV 17	MLV 20
Location	City of Beaumont	City of Riverside	City of Corona
Days on Site	16 days	32 days	28 days
Construction Start	08/17/2015	01/05/2016	08/26/2015
Construction Finish	09/30/2015	03/10/2016	10/19/2015
Commissioning Date	02/04/2016	07/27/2017	08/23/2017
Valve Upgrades			
Valve Number	2000-146.62-0	2000-167.00-0	2000-181.34-0
Valve Type	Existing – Ball	Existing – Ball	Existing – Ball
Actuator	Existing	Existing	Existing
Actuator Above-/Below-Grade	Above-Grade	Above-Grade	Above-Grade
ASV	Yes	Yes	Yes
RCV	Yes	Yes	Yes
Site Upgrades			
Vault	None	None	None
Power	Existing – Utility	New – Utility	New – Utility
Communication	New – Radio	New – Radio	New – Radio
SCADA Panel	New	New	New
Equipment Shelter	None	New	New
Fencing	Existing	Expanded	Expanded
Project Costs (\$)	Capital	O&M	Total
Loaded Project Costs	2,786,310	-	2,786,310
Disallowed Costs	-	-	-

Pipeline Safety Enhancement Plan Final Report Line 2000 Beaumont Riverside Valve Enhancement Project Bundle

B. Maps and Images

Figure 1: Satellite Image of Line 2000 Beaumont Riverside Valve Enhancement Project Bundle: Overview



Pipeline Safety Enhancement Plan Final Report Line 2000 Beaumont Riverside Valve Enhancement Project Bundle

Figure 2: Satellite Image of MLV 14



Pipeline Safety Enhancement Plan Final Report Line 2000 Beaumont Riverside Valve Enhancement Project Bundle

Figure 3: Satellite Image of MLV 17



Pipeline Safety Enhancement Plan Final Report Line 2000 Beaumont Riverside Valve Enhancement Project Bundle

Figure 4: Satellite Image of MLV 20

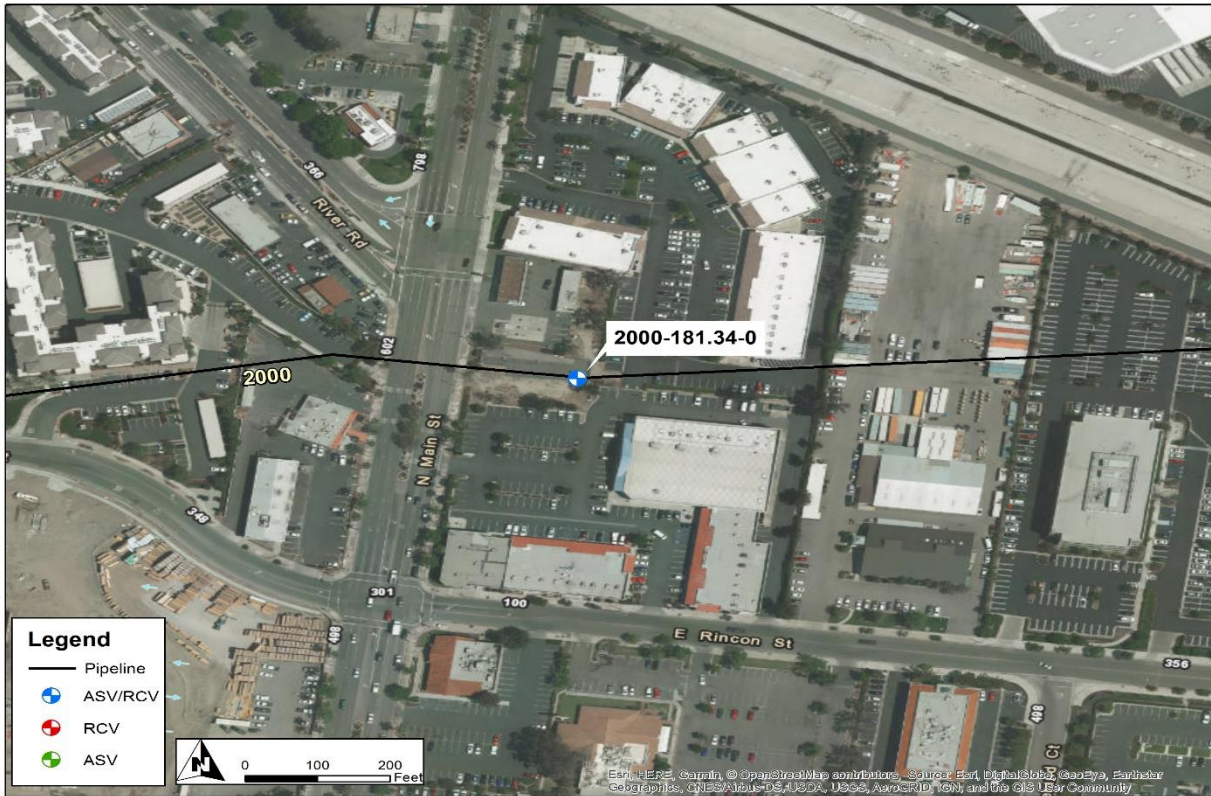

Pipeline Safety Enhancement Plan Final Report
Line 2000 Beaumont Riverside Valve Enhancement Project Bundle

II. ENGINEERING, DESIGN, AND PLANNING

A. Project Scope

SoCalGas and SDG&E presented a conceptual project scope in workpapers supporting the Valve Enhancement Plan¹ in the 2011 filing. This conceptual scope did not include this project. SoCalGas and SDG&E reviewed available information and performed a detailed system flow analysis that identified these valves for enhancement to provide the planned isolation. The final project scope is summarized in Table 2 below.

1. 2011 PSEP Filing: SoCalGas and SDG&E did not identify these valves for automation to achieve the objective of rapid system isolation.
2. Updated Scope: Line 2000 crosses multiple geological threats and high concentration area (HCA) locations, which required isolation. SoCalGas and SDG&E determined that the automation of these valves would achieve the transmission isolation objectives set forth in the Valve Enhancement Plan.
3. Engineering, Design, and Constructability: No notable engineering adjustments were required to the standard design.
4. Final Project Scope: The final project scope consists the automation of three valves that included the installation of power equipment, the installation of communications equipment, and the installation of necessary automation equipment at the sites.

¹ See Workpapers supporting Amended Pipeline Safety Enhancement Plan (PSEP) of SoCalGas and SDG&E, submitted on December 2, 2011, at WP-IX-2-14 through WP-IX-2-25 (A.11-11-002 Exh. # SCG-32).

Pipeline Safety Enhancement Plan Final Report
Line 2000 Beaumont Riverside Valve Enhancement Project Bundle

Table 2: Final Project Scope

Final Project Scope					
Line	Mile	Valve #	Valve Size (confidential)	Installation Type	Function
2000	146.62	0	████████	C/P	ASV/RCV
2000	167.00	0	████████	C/P	ASV/RCV
2000	181.34	0	████████	C/P	ASV/RCV

B. Site Evaluation and Planning

SoCalGas and SDG&E initiated the planning process for the Line 2000 Beaumont Riverside Valve Enhancement Project Bundle by performing a pre-design site walk to determine the existing conditions and assess any potential impacts on the design. Key factors that influenced the engineering and design of this project are as follows:

MLV 14

1. Site Description: This site is an existing SoCalGas facility in an area that is a commercial and industrial mix.
2. Land Issues: During the pre-design site walk, the Project Team noted that the existing facility can accommodate the new equipment.
3. DOT Class: This project site is in a Class 3 location.
4. Power Source: The site has existing utility power.
5. Communication Technology: There was no preexisting communications equipment, the Project Team installed new communications equipment at the site.

Pipeline Safety Enhancement Plan Final Report Line 2000 Beaumont Riverside Valve Enhancement Project Bundle

MLV 17

1. Site Description: This site is an existing SoCalGas facility in a residential area.
2. Land Issues: During the pre-design site walk, the Project Team noted that the existing station would need to be expanded to accommodate the additional equipment.
3. DOT Class: This project site is in a Class 3 location.
4. Power Source: There was no preexisting power source, the Project Team installed new power equipment at the site.
5. Communication Technology: There was no preexisting communications equipment, the Project Team installed new communications equipment at the site.

MLV 20

1. Site Description: This site is an existing SoCalGas facility located in a high-density, commercial area.
2. Land Issues: During the pre-design site walk, the Project Team noted that the existing station would need to be expanded to accommodate the additional equipment.
3. DOT Class: This project site is in a Class 3 location.
4. Power Source: There was no preexisting power source, the Project Team installed new power equipment at the site.
5. Communication Technology: There was no preexisting communications equipment, the Project Team installed new communications equipment at the site.

Pipeline Safety Enhancement Plan Final Report
Line 2000 Beaumont Riverside Valve Enhancement Project Bundle

C. Engineering, Design, and Planning Factors

SoCalGas and SDG&E reviewed drawings and records, contacted internal planning groups, communicated with external stakeholders, conducted survey activity, and completed a site walk. Key factors that influenced the engineering and design of the Project are as follows:

MLV 14

1. Engineering Assessment: During the site evaluation, the Project Team confirmed the existing technology and verified that the station could accommodate the new equipment.
2. Valve Details: The existing valve was a manually actuated Class 600 ball valve that the Project Team reused.
3. Actuator Details: The existing actuator was a double-acting pneumatic actuator that the Project Team reused.
4. Customer Impact: The Project Team did not anticipate service disruptions to customers.
5. Community Impact: The Project Team did not anticipate any notable impacts to the community from this Project.
6. Substructures: The Project Team did not identify any existing substructures that affected the design and engineering at this site.
7. Environmental: The Project Team did not identify any notable environmental concerns at the site. An environmental monitor performed spot checks during construction.

Pipeline Safety Enhancement Plan Final Report
Line 2000 Beaumont Riverside Valve Enhancement Project Bundle

8. Permit Restrictions: There were no special permits or permit restrictions for this project site.
9. Land Use: The Project Team performed all work within the existing SoCalGas facility.
10. Traffic Control: The Project Team did not identify any traffic control needs at the site.

MLV 17

1. Engineering Assessment: During the site evaluation, the Project Team confirmed the existing technology and verified the need to expand the existing station, to accommodate the new equipment.
2. Valve Details: The existing valve was a manually actuated Class 600 ball valve that the Project Team reused.
3. Actuator Details: The existing actuator was a double-acting pneumatic actuator that the Project Team reused.
4. Customer Impact: The Project Team did not anticipate service disruptions to customers.
5. Community Impact: The Project Team did not anticipate any notable impacts to the community from this project.
6. Substructures: The Project Team did not identify any existing substructures that affected the design and engineering at this site.

Pipeline Safety Enhancement Plan Final Report
Line 2000 Beaumont Riverside Valve Enhancement Project Bundle

7. Environmental: The Project Team did not identify any notable environmental concerns at the site. An environmental monitor performed spot checks during construction.
8. Permit Restrictions: There were no special permits or permit restrictions for this project site.
9. Land Use: The Project Team performed all work within the existing SoCalGas easement.
10. Traffic Control: The Project Team did not identify any traffic control needs at the site.

MLV 20

1. Engineering Assessment: During the site evaluation, the Project Team confirmed the existing technology and verified the need to expand the existing station to accommodate the new equipment.
2. Valve Details: The existing valve was a manually actuated Class 600 ball valve that the Project Team reused.
3. Actuator Details: The existing actuator was s a double-acting pneumatic actuator that the Project Team reused.
4. Customer Impact: The Project Team did not anticipate service disruptions to customers.
5. Community Impact: The Project Team did not anticipate any impacts to the community from this project.

Pipeline Safety Enhancement Plan Final Report
Line 2000 Beaumont Riverside Valve Enhancement Project Bundle

6. Substructures: The Project Team did not identify any existing substructures that affected the design and engineering at this site.
7. Environmental: An Environmental Monitor was on site full-time during excavation and performed spot checks after excavation.
8. Permit Restrictions: There were no special permits or permit restrictions for this project site.
9. Land Use: The Project Team obtained a temporary right of entry (TRE) for construction.
10. Traffic Control: The Project Team did not identify any traffic control needs at the site.

Pipeline Safety Enhancement Plan Final Report Line 2000 Beaumont Riverside Valve Enhancement Project Bundle

Figure 5: Line 2000 Beaumont Riverside Valve Enhancement Project Bundle Schematic

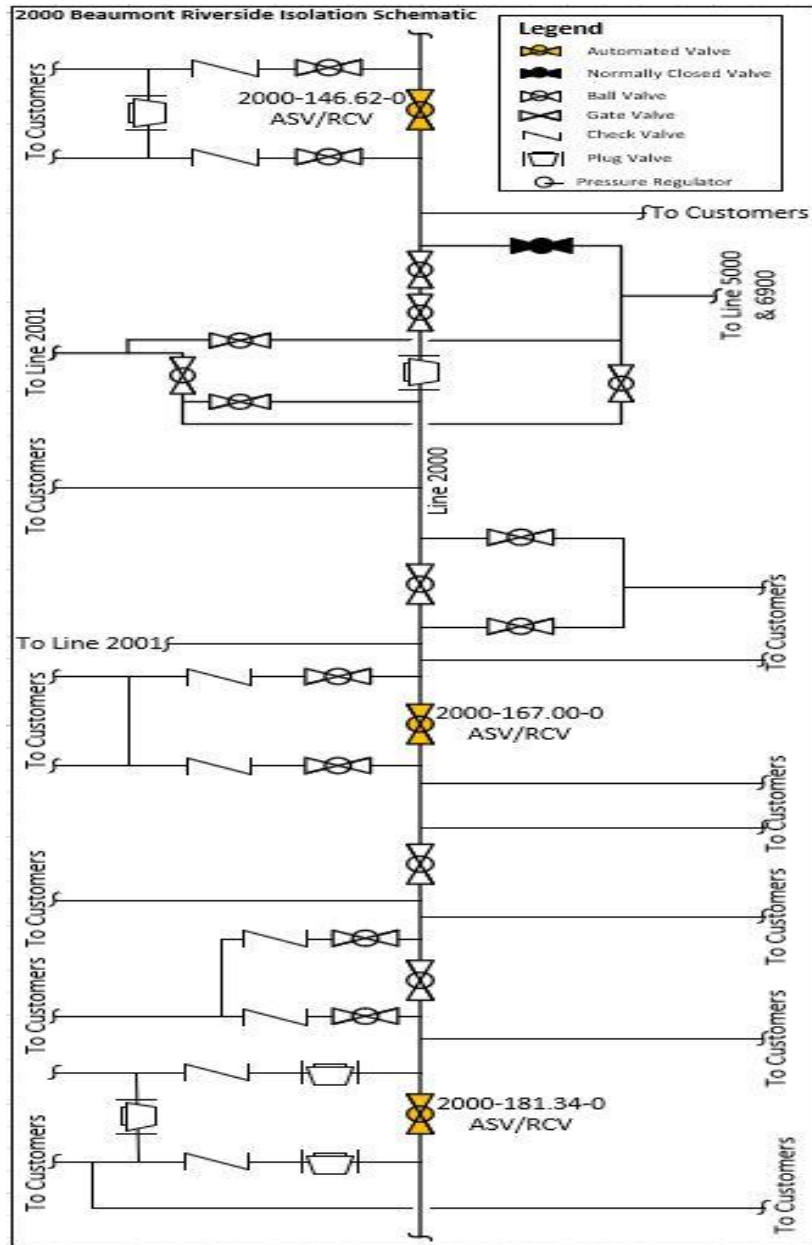

Pipeline Safety Enhancement Plan Final Report
Line 2000 Beaumont Riverside Valve Enhancement Project Bundle

D. Scope Changes

SoCalGas and SDG&E did not make any notable scope changes during detailed design.

Pipeline Safety Enhancement Plan Final Report
Line 2000 Beaumont Riverside Valve Enhancement Project Bundle

III. CONSTRUCTION

A. Construction Contractor Selection

The Project Team prepared an initial cost estimate based on the preliminary design. Following completion of the engineering, design, and planning activities described above, the Project Team directed the Performance Partner (Mechanical Construction Contractor) and Alliance Partner (Electrical Contractor) to prepare cost estimates based on a more detailed engineering design package. As indicated above, there were no notable changes in scope between the time when the Project Team prepared the preliminary cost estimate and when the Performance Partner and Alliance Partner prepared and submitted their estimates.

1. SoCalGas and SDG&E's Preliminary Mechanical Construction Contractor Estimate (*confidential*): SoCalGas and SDG&E's preliminary cost estimate for construction was [REDACTED].
2. Mechanical Construction Contractor's Target Price Estimate (*confidential*): The Mechanical Construction Contractor's cost estimate was [REDACTED], which was [REDACTED] than SoCalGas and SDG&E's preliminary cost estimate for construction.
3. SoCalGas and SDG&E's Preliminary Electrical Contractor Estimate (*confidential*): SoCalGas and SDG&E's preliminary cost estimate for construction was [REDACTED].
4. Electrical Contractor's Estimate (*confidential*): The Electrical Contractor's estimate was [REDACTED], which was [REDACTED] than SoCalGas and SDG&E's preliminary cost estimate.

Pipeline Safety Enhancement Plan Final Report
Line 2000 Beaumont Riverside Valve Enhancement Project Bundle

B. Construction Schedule

Table 3: Construction Timeline

MLV 14	
Construction Start Date	08/17/2015
Construction Completion Date	09/30/2015
Days on Site	16 days
Commissioning Date	02/04/2016
MLV 17	
Construction Start Date	01/05/2016
Construction Completion Date	03/10/2016
Days on Site	32 days
Commissioning Date	07/27/2017
/MLV 20	
Construction Start Date	08/26/2015
Construction Completion Date	10/19/2015
Days on Site	28 days
Commissioning Date	08/23/2017

The Project Team completed all construction activities as soon as practicable prior to commissioning. SoCalGas and SDG&E’s finalization of commissioning activities is dependent on electrical utility connections, and system and/or resource availability.

C. Changes During Construction

SoCalGas and SDG&E successfully mitigated conditions during construction in a manner that minimized potential impacts on project scope, cost, and schedule. As a result, these conditions did not result in any notable change orders.

Pipeline Safety Enhancement Plan Final Report Line 2000 Beaumont Riverside Valve Enhancement Project Bundle

Figure 6: MLV 14 – New Supervisory Control and Data Acquisition (SCADA) Cabinet and Bollards



Pipeline Safety Enhancement Plan Final Report Line 2000 Beaumont Riverside Valve Enhancement Project Bundle

Figure 7: MLV 20 – New Linebreak Cabinet



Pipeline Safety Enhancement Plan Final Report
Line 2000 Beaumont Riverside Valve Enhancement Project Bundle

D. Commissioning and Site Restoration

Commissioning activities included site restoration, final inspections, and placement of the valves back into service. During this stage, SoCalGas and SDG&E successfully performed site acceptance testing and conducted point-to-point verification with SoCalGas Gas Control personnel for the newly-automated valves. SoCalGas and SDG&E trained Field Operations personnel on the proper use and operation of the new equipment. Closeout activities included development of final drawings, the reconciliation package, and updates to company recordkeeping systems to reflect the completed scope of work. The sites were commissioned on February 4, 2016, July 27, 2017 and August 23, 2017, as summarized in Table 3.

Pipeline Safety Enhancement Plan Final Report
Line 2000 Beaumont Riverside Valve Enhancement Project Bundle

IV. PROJECT COSTS

A. Cost Avoidance Actions

SoCalGas and SDG&E exercised due diligence in the design, planning, and construction activities for this project to minimize or avoid costs when prudent to do so. As discussed above, the Project Team reviewed existing records, communicated with external stakeholders, and conducted a site walk to incorporate the known site conditions in the project plan and design. The Project Team bundled projects to coordinate engineering activity between the three project sites.

B. Cost Estimates

Based on the preliminary design, once the preliminary project scope was confirmed and engineering, design, and planning activities were underway, SoCalGas and SDG&E prepared an estimate of the Direct Costs of the Project in the amount of \$1,522,347. This estimate was prepared in May of 2015, using the “Stage 3 SCG Valve Estimate Template Rev 2” estimating tool, the most current version of the PSEP Estimate Template at the time. The Project Team considered the conditions known at the time to prepare the preliminary Direct Cost estimate. This estimate reflects the projected Labor, Material, and Services costs anticipated to be incurred to execute the Project, based on initial design plans.

SoCalGas and SDG&E estimated Indirect Costs of the Project based on the estimated Direct Costs and other project-related variables.

Pipeline Safety Enhancement Plan Final Report
Line 2000 Beaumont Riverside Valve Enhancement Project Bundle

C. Actual Direct and Indirect Costs

Actual Direct Costs reflect the Labor, Material, and Services costs incurred to execute the Project. Actual Indirect Costs reflect costs for incremental overhead loaders in accordance with Company overhead allocation policies. The total loaded cost of the Project is \$2,786,310.

Table 4: Estimated and Actual Direct Costs and Variances

Direct Costs (\$)	Estimate	Actuals	Delta Over/(Under)
Company Labor	65,259	112,300	47,041
Materials	167,710	193,887	26,177
Mechanical Construction Contractor	154,680	197,263	42,583
Electrical Contractor	406,930	422,513	15,583
Construction Management & Support	157,466	271,886	114,420
Environmental	126,225	126,163	(62)
Engineering & Design	203,647	675,433	471,786
Project Management & Services	72,932	76,202	3,270
ROW & Permits	6,600	63,810	57,210
GMA	160,898	273,718	112,820
Total Direct Costs	1,522,347	2,413,175	890,828

Table 5: Estimated and Actual Indirect Costs, Total Costs, and Variances

Indirect Costs/Total Costs (\$)	Estimate	Actuals	Delta Over/(Under)
Overheads	212,927	201,924	(11,003)
AFUDC	160,388	151,124	(9,264)
Property Taxes	33,691	20,087	(13,604)
Total Indirect Costs	407,006	373,135	(33,871)
Total Direct Costs	1,522,347	2,413,175	890,828
Total Loaded Costs	1,929,353	2,786,310	856,957

Pipeline Safety Enhancement Plan Final Report
Line 2000 Beaumont Riverside Valve Enhancement Project Bundle

V. CONCLUSION

SoCalGas and SDG&E enhanced the safety of their integrated natural gas system by prudently executing the Line 2000 Beaumont Riverside Valve Enhancement Project Bundle. Through this Valve Enhancement Project Bundle, SoCalGas and SDG&E successfully automated three mainline valves to achieve the objective of enabling rapid system isolation in the Cities of Beaumont, Riverside and Corona. The total loaded cost of the Project is \$2,786,310.

SoCalGas and SDG&E executed this project prudently through designing and executing the Project to support achievement of Valve Enhancement Plan isolation objectives, and by installing equipment necessary to bring power to two of the project sites and communication capabilities to three of the project sites to enable rapid system isolation to a portion of Line 2000.

SoCalGas and SDG&E engaged in prudent cost avoidance efforts to complete this safety enhancement work at a reasonable cost by carefully planning and coordinating construction activities and combining engineering efforts across three projects to maximize efficiencies and reduce customer and community impacts.

End of Line 2000 Beaumont Riverside Valve Enhancement Project Bundle Final Report

Pipeline Safety Enhancement Plan Final Report
Line 2001 Riverside Valve Enhancement Project Bundle

I. LINE 2001 RIVERSIDE VALVE ENHANCEMENT PROJECT BUNDLE

A. Background and Summary

This report describes the activities associated with the Line 2001 Riverside Valve Enhancement Project Bundle, that consists of valve enhancements made to two existing mainline valves (MLVs), one existing crossover valve, and the installation of two check valves in the cities of Riverside and Chino in San Bernardino County. Through this project, SoCalGas and SDG&E enhanced the capabilities of two MLVs and one crossover valve to enable rapid transmission system isolation to portions of Lines 2001 and 5000. SoCalGas and SDG&E installed two new actuators, two check valves, expanded the fencing at one of the project sites, new power equipment, new communications equipment, and the necessary automation equipment, at the sites. The total loaded project cost is \$2,478,621.

The valves comprising the Line 2001 Riverside Project Bundle are located in developed areas and are separated into two project sites. The MLV 18A site is an existing SoCalGas facility in an industrial area in the City of Riverside at the end of Payton Street. Next to the facility, there is an existing SoCalGas regulator station. The MLV 20A site is an existing SoCalGas facility in an agricultural field, in the City of Chino. The field is located next to the Chino Airport.

Pipeline Safety Enhancement Plan Final Report
Line 2001 Riverside Valve Enhancement Project Bundle

Table 1: General Project Information

Line 2001 Riverside Valve Enhancement Project Bundle		
Site	MLV 18A	MLV 20A
Location	City of Riverside	City of Chino
Days on Site	47 days	35 days
Construction Start	10/16/2015	11/16/2015
Construction Finish	10/18/2016	01/14/2016
Commissioning Date	12/13/2016	02/11/2016
Valve Upgrades		
Valve Number	2001-176.32-0	2001-186.70-0
Valve Type	Existing – Plug	Existing – Ball
Actuator	New	Existing
Actuator Above-/Below-Grade	Above	Above
ASV	Yes	Yes
RCV	Yes	Yes
Valve Number	N/A	2001-186.70-2
Valve Type	Check	Existing -- Ball
Actuator	N/A	New
Actuator Above-/Below-Grade	N/A	Above
ASV	N/A	No
RCV	N/A	Yes
Valve Number	N/A	
Valve Type	Check	
Actuator	N/A	
Actuator Above-/Below-Grade	N/A	
ASV	N/A	
RCV	N/A	
Site Upgrades		
Vault	None	None
Power	New – Utility	New – Solar
Communication	New – Radio	New – Radio
SCADA Panel	New	New
Equipment Shelter	New	New
Fencing	Yes – Expanded	Existing

Pipeline Safety Enhancement Plan Final Report
Line 2001 Riverside Valve Enhancement Project Bundle

Table 1: General Project Information (Continued)

Project Costs (\$)	Capital	O&M	Total
Loaded Project Costs	2,478,621	-	2,478,621
Disallowed Costs	-	-	-

Pipeline Safety Enhancement Plan Final Report
Line 2001 Riverside Valve Enhancement Project Bundle

B. Maps and Images

Figure 1: Satellite Image of Riverside 2001 Valve Enhancement Project Bundle: Overview



Pipeline Safety Enhancement Plan Final Report Line 2001 Riverside Valve Enhancement Project Bundle

Figure 2: MLV 18A

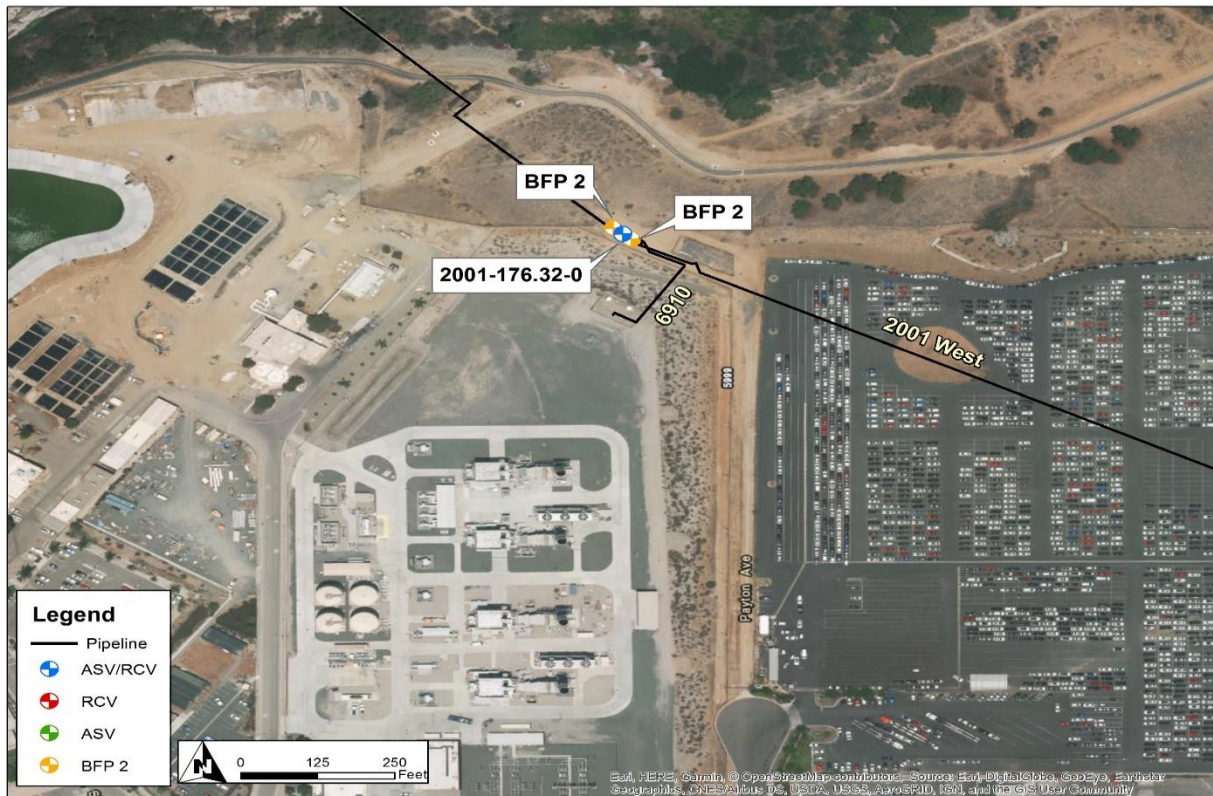

Pipeline Safety Enhancement Plan Final Report Line 2001 Riverside Valve Enhancement Project Bundle

Figure 3: MLV 20A



Pipeline Safety Enhancement Plan Final Report
Line 2001 Riverside Valve Enhancement Project Bundle

II. ENGINEERING, DESIGN, AND PLANNING

A. Project Scope

SoCalGas and SDG&E presented a conceptual project scope in workpapers supporting the Valve Enhancement Plan¹ in the 2011 filing. This conceptual scope identified two MLVs for automation to provide remote isolation to a portion of Lines 2001 and 5000. Prior to initiating execution of the Project, SoCalGas and SDG&E reviewed available information and performed a detailed system flow analysis to validate the scope of the Project. This resulted in the identification of an additional valve for enhancement and two check valve installations to provide the planned isolation. The final project scope is summarized in Table 2 below.

1. 2011 PSEP Filing: SoCalGas and SDG&E identified two MLVs for automation to achieve the objective of rapid system isolation.
2. Updated Scope: Upon project initiation, SoCalGas and SDG&E reviewed the conceptual project scope and determined that automation of these MLVs alone would not achieve the transmission isolation objectives set forth in the Valve Enhancement Plan. The Project Team determined that it was also necessary automate valve 2001-186.70-2, and install two check valves to prevent backflow on Line 2001. Together, the automation of these three valves and the installation of two check valves enabled rapid isolation, thereby achieving Valve Enhancement Plan objectives.

¹ See Workpapers supporting Amended Pipeline Safety Enhancement Plan (PSEP) of SoCalGas and SDG&E, submitted on December 2, 2011, at WP-IX-2-14 through WP-IX-2-25 (A.11-11-002 Exh. # SCG-32).

Pipeline Safety Enhancement Plan Final Report
Line 2001 Riverside Valve Enhancement Project Bundle

3. Engineering, Design, and Constructability:

- a. SoCalGas and SDG&E identified MLV 2001-186.70-2 for enhancement to isolate Line 2001 and Line 5000 from each other. Additionally, two check valves were identified for installation on the bridle around MLV 2001-176.32-0 that leads to Regulator station 824-II for backflow prevention.
- b. Valve 2001-176.32-0 (18 A) is a plug valve and is not piggable. The Project Team determined that a new actuator would achieve the automation objectives of PSEP and it could be reused if and when a new piggable valve is installed in the future.

4. Final Project Scope: The final project scope consists of the automation of three valves, that included the installation of two new actuators, the installation of power equipment, the installation of communications equipment, the installation of the necessary automation equipment at the project sites, and the installation of two new check valves.

Table 2: Final Project Scope

Final Project Scope					
Line	Mile	Valve #	Valve Size (<i>confidential</i>)	Installation Type	Function
2001	176.32	0	████████	A/AG	ASV/RCV
2001	176.32	N/A	████████	NV	BFP2
2001	176.32	N/A	████████	NV	BFP2
2001	186.70	0	████████	C/P	ASV/RCV
2001	186.70	2	████████	A/AG	RCV

Pipeline Safety Enhancement Plan Final Report
Line 2001 Riverside Valve Enhancement Project Bundle

B. Site Evaluation and Planning

SoCalGas and SDG&E initiated the planning process for the Riverside 2001 Valve Enhancement Project Bundle by performing a pre-design site walk to determine the existing conditions and assess any potential impact on the design. Key factors that influenced the engineering and design of this project are as follows:

MLV 18A

1. Site Description: This project site is an existing SoCalGas facility in the City of Riverside at the end of Payton Street. The site is to a parking lot and the Riverside Water Quality Control Facility. There is an existing chain link fence enclosing the site.
2. Land Issues: During the pre-design site walk, the Project Team noted that the existing station would need to be expanded to accommodate the additional equipment.
3. DOT Class: This project is in a Class 3 location.
4. Power Source: There was existing solar power at the site. The Project Team installed new utility power equipment to accommodate the increased loads from the new automation equipment.
5. Communication Technology: There was no preexisting communications equipment, the Project Team installed new communications equipment at the site.

Pipeline Safety Enhancement Plan Final Report
Line 2001 Riverside Valve Enhancement Project Bundle

MLV 20A

1. Site Description: This project site is an existing SoCalGas facility in the City of Chino next to the Chino airport. The station is in an agricultural field. There is an existing chain link fence enclosing the site.
2. Land Issues: During the pre-design site walk, the Project Team noted that the existing facility can accommodate the new equipment.
3. DOT Class: This project site is in a Class 1 location. SoCalGas and SDG&E selected this MLV for automation to isolate HCA locations upstream and downstream of this valve.
4. Power Source: The site had preexisting solar power. The Project Team installed new solar power equipment to accommodate the increased loads from the new automation equipment.
5. Communication Technology: There was no preexisting communications equipment, the Project Team installed new communications equipment at the site.

C. Engineering, Design, and Planning Factors

SoCalGas and SDG&E reviewed drawings and records, contacted internal planning groups, communicated with external stakeholders, conducted survey activity, and completed a pre-design site walk. Key factors that influenced the engineering and design of the Project are as follows:

Pipeline Safety Enhancement Plan Final Report
Line 2001 Riverside Valve Enhancement Project Bundle

MLV 18A

1. Engineering Assessment: The Project Team's initial design called for the solar power equipment at this site to be expanded to accommodate the increased loads from the new automation equipment. The Project Team later altered the design to utilize the existing utility power at the neighboring regulator station.
2. Valve Details: The existing valve was a manually actuated Class 300 plug valve that the Project Team reused.
3. Actuator Details: The preexisting actuator was incompatible with PSEP linebreak technology, the Project Team installed a new actuator.
4. Customer Impact: The Project Team requested a Request for Engineering Review (RER) for the installation of the new check valves that concluded that the required shut-in would impact one customer. SoCalGas and SDG&E's mitigation plan was to coordinate with the customer and align construction with their maintenance schedule to avoid the need for CNG/LNG support.
5. Community Impact: The Project Team did not anticipate any notable impacts to the community from this project.
6. Substructures: The Project Team did not identify any existing substructures that affected the design and engineering at this site.
7. Environmental: The Project Team did not identify any notable environmental concerns at the site. An environmental monitor performed spot checks during construction.
8. Permit Restrictions: The Project Team obtained a new above ground easement from Riverside County for the installation of the new automation equipment.

Pipeline Safety Enhancement Plan Final Report
Line 2001 Riverside Valve Enhancement Project Bundle

9. Land Use: The Project Team expanded the existing facility to accommodate the new automation equipment. The Project Team performed all work within the existing easement.
10. Traffic Control: The Project Team did not identify any traffic control needs at the site.

MLV 20A

1. Engineering Assessment: During the site evaluation, the Project Team confirmed the existing technology and verified that the station would accommodate the new equipment.
2. Valve Details:
 - a. 2001-186.70-0: The existing valve is a manually-actuated Class 300 ball valve that the Project Team reused.
 - b. 2001-186.70-2: The existing valve is a manually operated Class 300 ball valve that the Project Team reused.
3. Actuator Details:
 - a. 2001-186.70-0: The existing actuator is a double-acting pneumatic actuator that the Project Team reused.
 - b. 2001-186.70-2: There was no preexisting actuator, the Project Team installed a new actuator.
4. Customer Impact: The Project Team did not anticipate service disruptions to customers.

Pipeline Safety Enhancement Plan Final Report
Line 2001 Riverside Valve Enhancement Project Bundle

5. Community Impact: The Project Team did not anticipate any notable impact to the community from this project.
6. Substructures: The Project Team did not identify any existing substructures that affected the design and engineering at this site.
7. Environmental: The Project Team did not identify any notable environmental concerns at the site. An environmental monitor performed spot checks during construction.
8. Permit Restrictions: There were no special permits or permit restrictions for this project site.
9. Land Use: The Project Team performed all work within the existing easement.
10. Traffic Control: The Project Team did not identify any traffic control needs at the site.

Pipeline Safety Enhancement Plan Final Report Line 2001 Riverside Valve Enhancement Project Bundle

Figure 4: Line 2001 Riverside Valve Enhancement Project Bundle Schematic

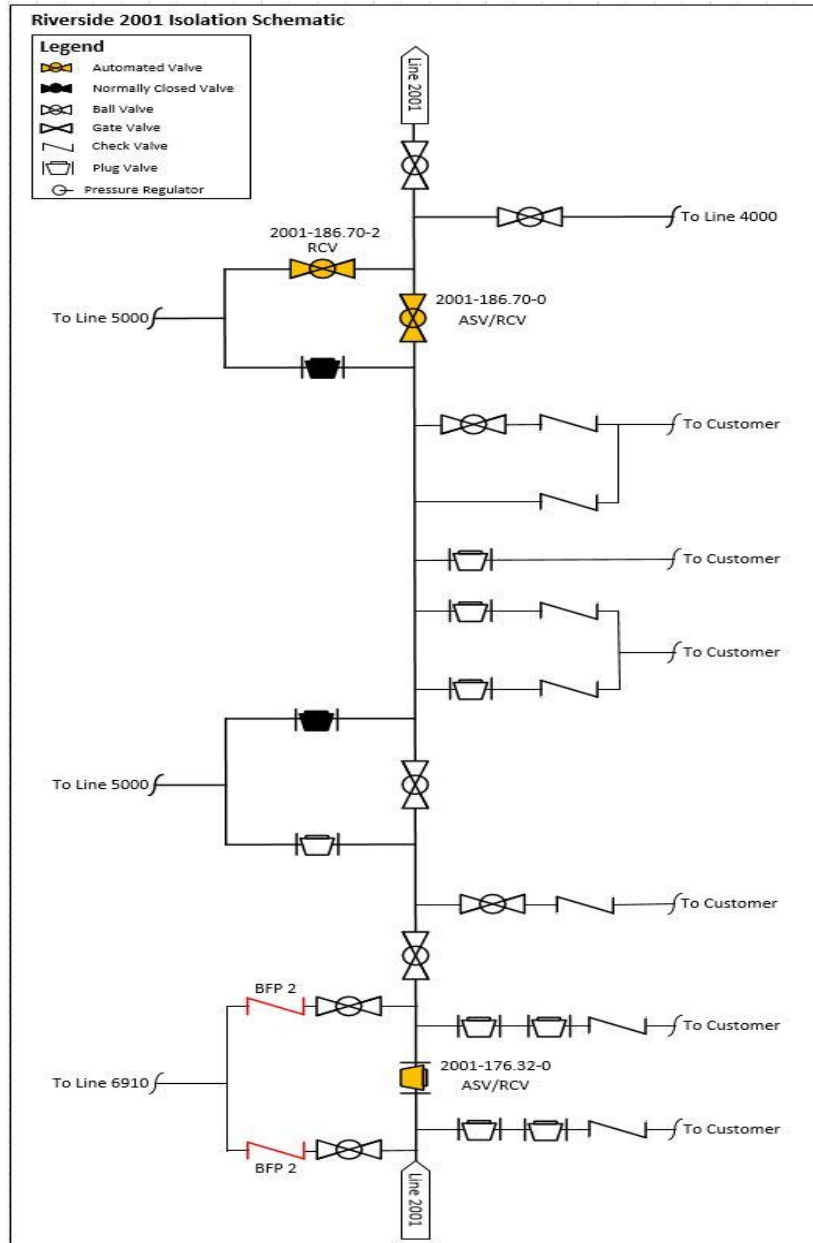

Pipeline Safety Enhancement Plan Final Report
Line 2001 Riverside Valve Enhancement Project Bundle

D. Scope Changes

Through engineering, design, and planning activities, SoCalGas and SDG&E determined that changes in scope were appropriate to enhance the design of the Project and address engineering factors. As a result, the preliminary cost estimate does not fully reflect the final scope. Summarized below is the notable change in scope made after the preliminary cost estimate was developed and approved.

The Project Team initially designed the MLV 18A site to include solar power. After the development of the preliminary estimate, the Project Team changed the design to utilize the utility power that was existing at the neighboring regulator station.

Pipeline Safety Enhancement Plan Final Report
Line 2001 Riverside Valve Enhancement Project Bundle

III. CONSTRUCTION

A. Construction Contractor Selection

The Project Team prepared an initial cost estimate based on the preliminary design. Following completion of the engineering, design, and planning activities described above, the Project Team directed the Performance Partner (Mechanical Construction Contractor) and Alliance Partner (Electrical Contractor) to prepare cost estimates based on a more detailed engineering design package. As indicated above, there were no notable changes in scope between the time when the Project Team prepared the preliminary cost estimate and when the Performance Partner and Alliance Partner prepared and submitted their estimates.

1. SoCalGas and SDG&E's Preliminary Mechanical Construction Contractor Estimate (*confidential*): SoCalGas and SDG&E's preliminary cost estimate for construction was [REDACTED].
2. Mechanical Construction Contractor's Target Price Estimate (*confidential*): The Mechanical Construction Contractor's cost estimate was [REDACTED], which was [REDACTED] than SoCalGas and SDG&E's preliminary cost estimate for construction.
3. SoCalGas and SDG&E's Preliminary Electrical Contractor Estimate (*confidential*): SoCalGas and SDG&E's preliminary cost estimate for construction was [REDACTED].
4. Electrical Contractor's Estimate (*confidential*): The Electrical Contractor's estimate was [REDACTED], which was [REDACTED] than SoCalGas and SDG&E's preliminary cost estimate.

Pipeline Safety Enhancement Plan Final Report
Line 2001 Riverside Valve Enhancement Project Bundle

B. Construction Schedule

Table 3: Construction Timeline²

MLV 18A	
Construction Start Date	10/16/2015
Construction Completion Date	10/18/2016
Days on Site	47 days
Commissioning Date	12/13/2016
MLV 20A	
Construction Start Date	11/16/2015
Construction Completion Date	01/14/2016
Days on Site	35 days
Commissioning Date	02/11/2016

The Project Team completed all construction activities as soon as practicable prior to commissioning. SoCalGas and SDG&E’s finalization of commissioning activities is dependent on electrical utility connections, and system and/or resource availability.

The Project Team requested an above ground easement for the work done at the MLV 18A site. The Project Team encountered delays in obtaining this easement and split construction into two phases. The first phase consisted of all below-ground work, that included the installation of the two new check valves. This phase occurred during the customers planned maintenance period avoiding the need for CNG/LNG support. The second phase consisted of all above ground work, including the electrical shelter and the new automation equipment.

² Days on site will generally be less than the number of days from construction start to construction completion. This is due to factors such as scheduling of construction crews and permitting conditions.

Pipeline Safety Enhancement Plan Final Report
Line 2001 Riverside Valve Enhancement Project Bundle

C. Changes During Construction

SoCalGas and SDG&E successfully mitigated conditions during construction in a manner that minimized potential impacts on project scope, cost, and schedule. As a result, these conditions did not result in any notable change orders.

Pipeline Safety Enhancement Plan Final Report
Line 2001 Riverside Valve Enhancement Project Bundle

Figure 5: MLV 18A – New Actuator and Existing Blowdown Stack in the Foreground. Existing Blowdown Stack, New Linebreak Cabinet and New Electrical Shelter in the Background



Pipeline Safety Enhancement Plan Final Report
Line 2001 Riverside Valve Enhancement Project Bundle

Figure 6: MLV 20A – Existing Actuator, New Actuator, Instrument Piping and New Linebreak Cabinet in the Foreground, New Electrical Shelter and Solar Array in the Background



Pipeline Safety Enhancement Plan Final Report
Line 2001 Riverside Valve Enhancement Project Bundle

D. Commissioning and Site Restoration

Commissioning activities included site restoration, final inspections, and placement of the valves into service. During this stage, SoCalGas and SDG&E successfully performed site acceptance testing and conducted point-to-point verification with SoCalGas Gas Control personnel for the newly-automated valves. SoCalGas and SDG&E trained Field Operations personnel on the proper use and operation of the new equipment. Closeout activities included development of final drawings, the reconciliation package, and updates to company recordkeeping systems to reflect the completed scope of work. The sites were commissioned on February 11, 2016 and December 13, 2016, as summarized in Table 3.

Pipeline Safety Enhancement Plan Final Report
Line 2001 Riverside Valve Enhancement Project Bundle

IV. PROJECT COSTS

A. Cost Avoidance Actions

SoCalGas and SDG&E exercised due diligence in the design, planning, and construction activities for this project to minimize or avoid costs when prudent to do so. As discussed above, the Project Team reviewed existing records, communicated with external stakeholders and conducted a site walk to incorporate the known site conditions in the project plan and design. Specific examples of cost avoidance actions taken on this project were:

1. Planning and Coordination:
 - a. The Project Team bundled projects to coordinate engineering and construction activity between the two project sites.
 - b. The Project Team scheduled construction so that the shut-in aligned with the customer's maintenance schedule thus avoiding the need for CNG or LNG.

B. Cost Estimates

Based on the preliminary design, once the preliminary project scope was confirmed and engineering, design, and planning activities were underway, SoCalGas and SDG&E prepared an estimate of the Direct Costs of the Project in the amount of \$1,535,617. This estimate was prepared in May of 2015, using the "Stage 3 SCG Valve Estimate Template Rev 2" estimating tool, the most current version of the PSEP Estimate Template at the time. The Project Team considered the conditions known at the time to prepare the preliminary Direct Cost estimate. This estimate reflects the projected Labor, Material, and Services costs anticipated to be incurred to execute the Project, based on initial design plans.

Pipeline Safety Enhancement Plan Final Report
Line 2001 Riverside Valve Enhancement Project Bundle

SoCalGas and SDGE estimated Indirect Costs of the Project based on the estimated Direct Costs and other project-related variables.

C. Actual Direct and Indirect Costs

Actual Direct Costs reflect the Labor, Material, and Services costs incurred to execute the Project. Actual Indirect Costs reflect costs for incremental overhead loaders in accordance with Company overhead allocation policies. The total loaded cost of the Project is \$2,478,621.

Table 4: Estimated and Actual Direct Costs and Variances

Direct Costs (\$)	Estimate	Actuals	Delta Over/(Under)
Company Labor	146,578	150,839	4,261
Materials	210,751	223,773	13,022
Mechanical Construction Contractor	238,433	239,999	1,566
Electrical Contractor	267,608	329,805	62,197
Construction Management & Support	71,250	162,043	90,793
Environmental	84,150	107,891	23,741
Engineering & Design	201,368	520,897	319,529
Project Management & Services	137,778	110,746	(27,032)
ROW & Permits	15,400	16,852	1,452
GMA	162,301	241,742	79,441
Total Direct Costs	1,535,617	2,104,587	568,970

Table 5: Estimated and Actual Indirect Costs, Total Costs, and Variances

Indirect Costs/Total Costs (\$)	Estimate	Actuals	Delta Over/(Under)
Overheads	184,603	212,744	28,141
AFUDC	119,648	143,420	23,772
Property Taxes	25,133	17,870	(7,263)
Total Indirect Costs	329,384	374,034	44,650
Total Direct Costs	1,535,617	2,104,587	568,970
Total Loaded Costs	1,865,001	2,478,621	613,620

Pipeline Safety Enhancement Plan Final Report
Line 2001 Riverside Valve Enhancement Project Bundle

V. CONCLUSION

SoCalGas and SDG&E enhanced the safety of their integrated natural gas system by prudently executing the Line 2001 Riverside Valve Enhancement Project Bundle. Through this Valve Enhancement Project Bundle, SoCalGas and SDG&E successfully automated two mainline valves, one crossover valve, and installed two check valves to achieve the objective of enabling rapid system isolation in the Cities of Chino and Riverside. The total loaded cost of the Project is \$2,478,621.

SoCalGas and SDG&E executed this project prudently through: designing and executing the Project to support the Valve Enhancement Plan isolation objectives, coordinating and bundling two valve projects into a comprehensive construction package to capture efficiencies through coordinated scheduling of construction crews, and installing equipment necessary to bring power and communication capabilities to these valves to enable rapid system isolation to a portion of Line 2001 and Line 5000.

SoCalGas and SDG&E engaged in prudent cost avoidance efforts to complete this safety enhancement at a reasonable cost by carefully planning and coordinating construction activity, limiting the number of mobilizations across two different project sites to maximize efficiencies, and reducing customer and community impacts, and by engaging in efforts to avoid the use of CNG and LNG.

Pipeline Safety Enhancement Plan Final Report
Line 2001 West Section 10 and 11 Valve Enhancement Project

I. LINE 2001 WEST SECTION 10 AND 11 VALVE ENHANCEMENT PROJECT

A. Background and Summary

This report describes the activities associated with the Line 2001 West Section 10 and 11 Valve Enhancement Project that consists of valve enhancements made to an existing mainline valve (MLV) in the City of Banning in Riverside County. Through this project, SoCalGas and SDG&E enhanced the capabilities of one MLV to provide rapid transmission system isolation to a portion of Line 2001. SoCalGas and SDG&E installed a vault lid, power equipment, communications equipment, and the necessary automation equipment at the site. The total loaded project cost is \$1,544,982.

The Line 2001 Section 10 and 11 Valve Enhancement Project site is located in an undeveloped area next to a residential development in the City of Banning near the intersection of Morongo Road and North Hathaway Street. The City of Banning plans to develop the area around the project site in the future.

Pipeline Safety Enhancement Plan Final Report
Line 2001 West Section 10 and 11 Valve Enhancement Project

Table 1: General Project Information

Line 2001 West Section 10 and 11 Valve Enhancement Project			
Location	City of Banning		
Days on Site	31 days		
Construction Start	01/09/2017		
Construction Finish	03/13/2017		
Commissioning Date	01/08/2018		
Valve Upgrades			
Valve Number	2001-139.76-0		
Valve Type	Existing – Ball		
Actuator	Existing		
Actuator Above-/Below- Grade	Below-Grade		
ASV	Yes		
RCV	Yes		
Site Upgrades			
Vault	New – Lid		
Power	New – Utility		
Communication	New – Radio		
SCADA Panel	Yes		
Equipment Shelter	None		
Fencing/Wall	None		
Project Costs (\$)	Capital	O&M	Total
Loaded Project Costs	1,544,982	-	1,544,982
Disallowed Costs	-	-	-

Pipeline Safety Enhancement Plan Final Report
Line 2001 West Section 10 and 11 Valve Enhancement Project

B. Maps and Images

Figure 1: Satellite Image of Valve - Line 2001 West Section 10 and 11 Site

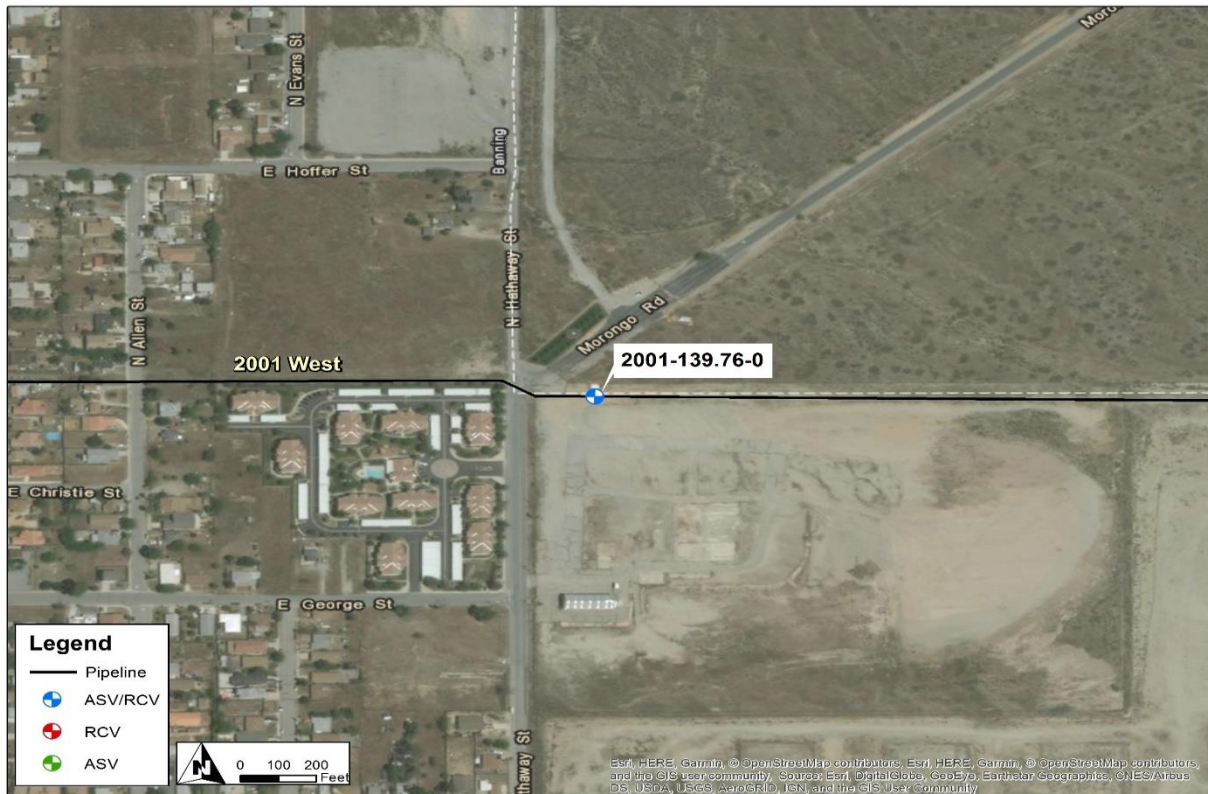

Pipeline Safety Enhancement Plan Final Report
Line 2001 West Section 10 and 11 Valve Enhancement Project

II. ENGINEERING, DESIGN, AND PLANNING

A. Project Scope

SoCalGas and SDG&E presented a conceptual project scope in workpapers supporting the Valve Enhancement Plan¹ in the 2011 filing. This conceptual scope did not include this project. SoCalGas and SDG&E reviewed available information and performed a detailed system flow analysis that identified this valve as a candidate for enhancement to provide the planned isolation. The final project scope is summarized in Table 2 below.

1. 2011 PSEP Filing: SoCalGas and SDG&E did not identify this valve for automation to achieve the objective of rapid system isolation.
2. Updated Scope: SoCalGas and SDG&E determined that the automation of MLV 2001-139.76-0 would enable rapid isolation, achieving Valve Enhancement Plan objectives.
3. Engineering, Design, and Constructability: As a part of the PSEP Line 2001 West Project², SoCalGas and SDG&E installed MLV 2001-139.76-0. The valve was installed in a vault. Due to requirements set by the City of Banning, a custom vault lid was required, this lid was not installed during the PSEP Line 2001 West Project. The Line 2001 West Section 10 and 11 Valve Enhancement Project planned to install an actuator, a vault, and a vault lid.

¹ See Workpapers supporting Amended Pipeline Safety Enhancement Plan (PSEP) of SoCalGas and SDG&E, submitted on December 2, 2011, at WP-IX-2-14 through WP-IX-2-25 (A.11-11-002 Exh. # SCG-32).

² The final report the Line 2001 West Project was submitted in workpapers supporting A.16-09-005, WP-III-A2 and includes a description of the activities and costs associated with the installation of MLV 2001-139.76-0, initially known as MLV 2001-141.00-0.

Pipeline Safety Enhancement Plan Final Report
Line 2001 West Section 10 and 11 Valve Enhancement Project

4. **Final Project Scope:** The final scope for this project consists of the automation of one valve that included the installation of power equipment, communications equipment, and the necessary automation equipment at the project site.

Table 2: Final Project Scope

Final Project Scope					
Line	Mile	Valve #	Valve Size (confidential)	Installation Type	Function
2001	139.76	0		C/P	ASV/RCV

B. Site Evaluation and Planning

SoCalGas and SDG&E initiated the planning process for the Line 2001 West Section 10 and 11 Valve Enhancement Project by performing a pre-design site walk to determine the existing conditions and assess any potential impacts on the design. Key factors that influenced the engineering and design of this project are as follows:

1. **Site Description:** The site is located behind a gate along a fire road adjacent to the Morongo Indian Reservation and a residential neighborhood, off Hathaway Street and Morongo Road in the City of Banning. The site is currently located in an undeveloped area and the City of Banning plans to develop the land around the project site in the future.
2. **Land Issues:** The Project Team acquired new above and below ground easements for the new automation equipment.
3. **DOT Class:** This site is in a Class 3 location.
4. **Power Source:** There was no preexisting power source, the Project Team installed new power equipment at the site.

Pipeline Safety Enhancement Plan Final Report
Line 2001 West Section 10 and 11 Valve Enhancement Project

5. Communication Technology: There was no preexisting communications equipment, the Project Team installed new communications equipment at the site.

C. Engineering, Design, and Planning Factors

SoCalGas and SDG&E reviewed drawings and records, contacted internal planning groups, communicated with external stakeholders, conducted survey activity and completed a pre-design site walk. Key factors that influenced the engineering and design of the Project are as follows:

1. Engineering Assessment: During the site evaluation, the Project Team confirmed the existing technology. There were no items of note that affected the design.
2. Valve Details: The valve was a manually actuated Class 600 ball valve and was reused.
3. Actuator Details: The existing actuator was a double-acting pneumatic actuator that the Project Team reused.
4. Customer Impact: The Project Team did not anticipate service disruptions to customers.
5. Community Impact: The Project team did not anticipate any notable impacts to the community from this Project.
6. Substructures: The Project Team did not identify any existing substructures that affected the design and engineering at this site.
7. Environmental: The Project Team did not identify any notable environmental concerns at the site. An environmental monitor performed spot checks during construction.

Pipeline Safety Enhancement Plan Final Report
Line 2001 West Section 10 and 11 Valve Enhancement Project

8. Permit Restrictions: The Project Team obtained a permit to install utility power from the City of Banning.
9. Land Use: The Project Team acquired new above and below ground easements for the new automation equipment. The Project Team used the existing easement for a laydown yard
10. Traffic Control: The Project Team did not identify any traffic control needs at the site.

Pipeline Safety Enhancement Plan Final Report Line 2001 West Section 10 and 11 Valve Enhancement Project

Figure 2: Line 2001 West Section 10 and 11 Valve Enhancement Project Schematic

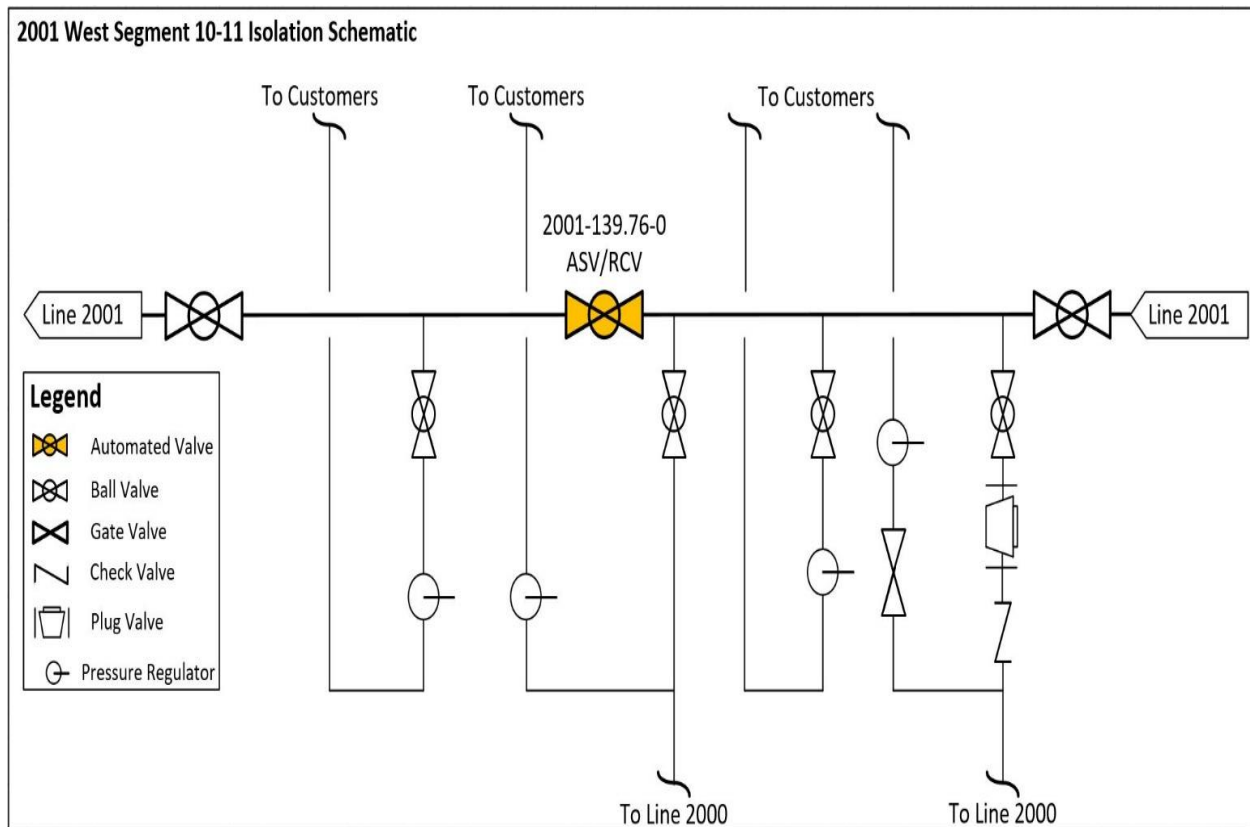

Pipeline Safety Enhancement Plan Final Report
Line 2001 West Section 10 and 11 Valve Enhancement Project

D. Scope Changes

SoCalGas and SDG&E did not make any notable scope changes during detailed design.

Pipeline Safety Enhancement Plan Final Report
Line 2001 West Section 10 and 11 Valve Enhancement Project

III. CONSTRUCTION

A. Construction Contractor Selection

The Project Team prepared an initial cost estimate based on the preliminary design. Following completion of the engineering, design, and planning activities described above, the Project Team directed the Performance Partner (Mechanical Construction Contractor) and Alliance Partner (Electrical Contractor) to prepare cost estimates based on a more detailed engineering design package. As indicated above, there were no notable changes in scope between the time when the Project Team prepared the preliminary cost estimate and when the Performance Partner and Alliance Partner prepared and submitted their estimates.

1. SoCalGas and SDG&E's Preliminary Mechanical and Electrical Construction Contractor Estimate (*confidential*): SoCalGas and SDG&E's preliminary cost estimate for construction was [REDACTED].
2. Mechanical and Electrical Construction Contractor's Target Price Estimate (*confidential*): The Mechanical Construction Contractor's cost estimate was [REDACTED], which was [REDACTED] than SoCalGas and SDG&E's preliminary cost estimate for construction.

Pipeline Safety Enhancement Plan Final Report
Line 2001 West Section 10 and 11 Valve Enhancement Project

B. Construction Schedule

Table 3: Construction Timeline

Construction Start Date	01/09/2017
Construction Completion Date	03/13/2017
Days on Site	31 days
Commissioning Date	01/08/2018

The Project Team completed all construction activities as soon as practicable prior to commissioning. SoCalGas and SDG&E’s finalization of commissioning activities is dependent on electrical utility connections, and system and/or resource availability.

C. Changes During Construction

SoCalGas and SDG&E successfully mitigated conditions during construction in a manner that minimized potential impacts on project scope, cost, and schedule. As a result, these conditions did not result in any notable change orders.

Pipeline Safety Enhancement Plan Final Report Line 2001 West Section 10 and 11 Valve Enhancement Project

Figure 3: New Communications Antenna



Pipeline Safety Enhancement Plan Final Report Line 2001 West Section 10 and 11 Valve Enhancement Project

Figure 4: Open Air Vault



Pipeline Safety Enhancement Plan Final Report
Line 2001 West Section 10 and 11 Valve Enhancement Project

D. Commissioning and Site Restoration

Commissioning activities included site restoration, final inspections, and placement of the actuators into service. During this stage, SoCalGas and SDG&E successfully performed site acceptance testing and conducted point-to-point verification with SoCalGas Gas Control personnel for the newly-automated valve. SoCalGas and SDG&E trained Field Operations personnel on the proper use and operation of the new equipment. Closeout activities included development of final drawings, the reconciliation package, and updates to company recordkeeping systems to reflect the completed scope of work. The site was commissioned on January 8, 2018, as summarized in Table 3.

Pipeline Safety Enhancement Plan Final Report
Line 2001 West Section 10 and 11 Valve Enhancement Project

IV. PROJECT COSTS

A. Cost Avoidance Actions

SoCalGas and SDG&E exercised due diligence in the design, planning, and construction activities for this project to minimize or avoid costs when prudent to do so. As discussed above, the Project Team reviewed existing records, communicated with external stakeholders, and conducted a site walk to incorporate the known site conditions in the project plan and design. Specific examples of cost avoidance actions taken on this project were:

1. Land Use: The Project team utilized existing easements for a laydown yard.
2. Planning and Coordination: The Project Team reviewed the design with the City of Banning and determined the placement of the new cabinets to allow for the future expansion of North Hathaway Street avoiding the need to relocate them in the future.

B. Cost Estimates

Based on the preliminary design, once the preliminary project scope was confirmed and engineering, design, and planning activities were underway, SoCalGas and SDG&E prepared an estimate of the Direct Costs of the Project in the amount of \$1,767,984. This estimate was prepared in August of 2015, using the “Stage 3 SCG Estimating Template Rev 3” estimating tool, the most current version of the PSEP Estimate Template at the time. The Project Team considered the conditions known at the time to prepare the preliminary Direct Cost estimate.

Pipeline Safety Enhancement Plan Final Report
Line 2001 West Section 10 and 11 Valve Enhancement Project

This estimate reflects the projected Labor, Material and Services costs anticipated to be incurred to execute the Project, based on initial design plans.

SoCalGas and SDG&E estimated Indirect Costs of the Project based on the estimated Direct Costs and other project-related variables.

C. Actual Direct and Indirect Costs

Actual Direct Costs reflect the Labor, Material, and Services costs incurred to execute the Project. Actual Indirect Costs reflect costs for incremental overhead loaders in accordance with Company overhead allocation policies. The total loaded cost of the Project is \$1,544,982.

Table 4: Estimated and Actual Direct Costs and Variances

Direct Costs (\$)	Estimate	Actuals	Delta Over/(Under)
Company Labor	126,000	60,420	(65,580)
Materials	384,098	198,414	(185,684)
Mechanical Construction Contractor	405,938	190,829	(215,109)
Electrical Contractor	-	146,108	146,108
Construction Management & Support	51,010	66,390	15,380
Environmental	162,250	-	(162,250)
Engineering & Design	376,366	441,826	65,460
Project Management & Services	61,691	36,836	(24,855)
ROW & Permits	30,250	24,285	(5,965)
GMA	170,381	153,483	(16,898)
Total Direct Costs	1,767,984	1,318,591	(449,393)

Pipeline Safety Enhancement Plan Final Report
Line 2001 West Section 10 and 11 Valve Enhancement Project

Table 5: Estimated and Actual Indirect Costs, Total Costs, and Variances

Indirect Cost/Total Costs (\$)	Estimate	Actuals	Delta Over/(Under)
Overheads	212,684	130,696	(81,988)
AFUDC	18,689	83,786	65,097
Property Taxes	966	11,909	10,943
Total Indirect Costs	232,339	226,391	(5,948)
Total Direct Costs	1,767,984	1,318,591	(449,393)
Total Loaded Costs	2,000,323	1,544,982	(455,341)

Pipeline Safety Enhancement Plan Final Report
Line 2001 West Section 10 and 11 Valve Enhancement Project

V. CONCLUSION

SoCalGas and SDG&E enhanced the safety of their integrated natural gas system by prudently executing the Line 2001 West Section 10 and 11 Valve Enhancement Project. Through this Valve Enhancement Project, SoCalGas and SDG&E successfully automated one mainline valve to achieve the objective of enabling rapid system isolation in City of Banning. The total loaded cost of the Project is \$1,544,982.

SoCalGas and SDG&E executed this project prudently through designing and executing the Project to support achievement of Valve Enhancement Plan isolation objectives, and by installing the equipment necessary to bring utility power and communication capabilities to this valve to enable rapid automated isolation of portions of Line 2001 in the City of Banning.

SoCalGas and SDG&E engaged in prudent cost avoidance efforts to complete this safety enhancement at a reasonable cost by scheduling the installation of a new mainline valve during the PSEP Line 2001 West Project, engaging in reasonable efforts to promote competitive and market-based rates for contractor services and materials; and using a reasonable amount of Company and contractor resources to complete this safety enhancement work as soon as practicable.

End of Valve Line 2001 West Section 10 and 11 Valve Enhancement Project Final Report

Pipeline Safety Enhancement Plan Final Report
Line 2003 East Valve Enhancement Project Bundle

I. LINE 2003 EAST VALVE ENHANCEMENT PROJECT BUNDLE

A. Background and Summary

This report describes the activities associated with the Line 2003 East Valve Enhancement Project Bundle that consists of valve enhancements made to two existing mainline valves (MLVs), two existing crossover valves, one valve feeding the regulator station, and the installation of two check valves in the Cities of Pico Rivera, Cudahy, and South Gate. Through this project, SoCalGas and SDG&E enhanced the capabilities of the valves and installed two check valves to enable rapid transmission system isolation to portions of Line 2003. SoCalGas and SDG&E installed four new actuators, two check valves, new power equipment, new communications equipment, and the necessary automation equipment at the sites. The total loaded project cost is \$4,436,317.

The valves comprising the Line 2003 East Valve Enhancement Project Bundle are located in urban areas and are separated into three project sites. The Slauson and Industry site is in the City of Pico Rivera and is located in the backlot of a commercial equipment rental facility. Access to the backlot is restricted. The Salt Lake Station is an existing SoCalGas facility in an industrial and residential neighborhood in the City of Cudahy. The Southern and Alameda site is in a residential area next to transmission electrical lines in the City of South Gate. SoCalGas and SDG&E grouped the three project sites together into a single valve bundle and executed the three sites as a comprehensive package because the sites are geographically proximate and located where the Project Team could manage the work load between project sites and capture efficiencies by coordinating engineering activities between the three sites.

Pipeline Safety Enhancement Plan Final Report
Line 2003 East Valve Enhancement Project Bundle

Table 1: General Project Information

Line 2003 East Valve Enhancement Project Bundle			
Site	Slauson and Industry	Salt Lake Station	Southern and Alameda
Location	Pico Rivera	Cudahy	South Gate
Days on Site	61 days	54 days	42 days
Construction Start	01/17/2017	09/21/2015	9/28/2015
Construction Finish	03/14/2017	01/22/2016	12/16/2015
Commissioning Date	10/04/2017	03/10/2016	09/26/2017
Valve Upgrades			
Valve Number	2003-0.78-0	2003-5.94-0	2003-8.80-3
Valve Type	Existing – Ball	Existing – Ball	Existing – Ball
Actuator	New	Existing	New
Actuator Above-/Below- Grade	Above-Grade	Above-Grade	Above-Grade
ASV	Yes	Yes	No
RCV	Yes	Yes	Yes
Valve Number	2003-0.78-1	N/A	
Valve Type	Existing – Ball	New – Check	
Actuator	New	N/A	
Actuator Above-/Below- Grade	Above-Grade	Below-Grade	
ASV	No	N/A	
RCV	Yes	N/A	
Valve Number	2003-0.78-2	N/A	
Valve Type	Existing – Ball	New – Check	
Actuator	New	N/A	
Actuator Above-/Below- Grade	Above-Grade	Below-Grade	
ASV	No	N/A	
RCV	Yes	N/A	
Site Upgrades			
Vault	None	None	Existing – Demolished
Power	New – Utility	Existing – Utility	New – Utility
Communication	New – Radio	Existing – Radio	New – Radio
SCADA Panel	New	New	New
Equipment Shelter	New	Existing	None
Fencing	New	Existing	Existing

Pipeline Safety Enhancement Plan Final Report
Line 2003 East Valve Enhancement Project Bundle

Table 1: General Project Information (Continued)

Project Costs (\$)	Capital	O&M	Total
Loaded Project Costs	4,436,307	10	4,436,317
Disallowed Costs	-	-	-

Pipeline Safety Enhancement Plan Final Report Line 2003 East Valve Enhancement Project Bundle

B. Maps and Images

Figure 1: Satellite Image of Line 2003 East Valve Enhancement Project Bundle: Overview



Pipeline Safety Enhancement Plan Final Report Line 2003 East Valve Enhancement Project Bundle

Figure 2: Satellite Image of Slauson and Industry



Pipeline Safety Enhancement Plan Final Report Line 2003 East Valve Enhancement Project Bundle

Figure 3: Satellite Image of Salt Lake Station



Pipeline Safety Enhancement Plan Final Report Line 2003 East Valve Enhancement Project Bundle

Figure 4: Satellite Image of Southern and Alameda

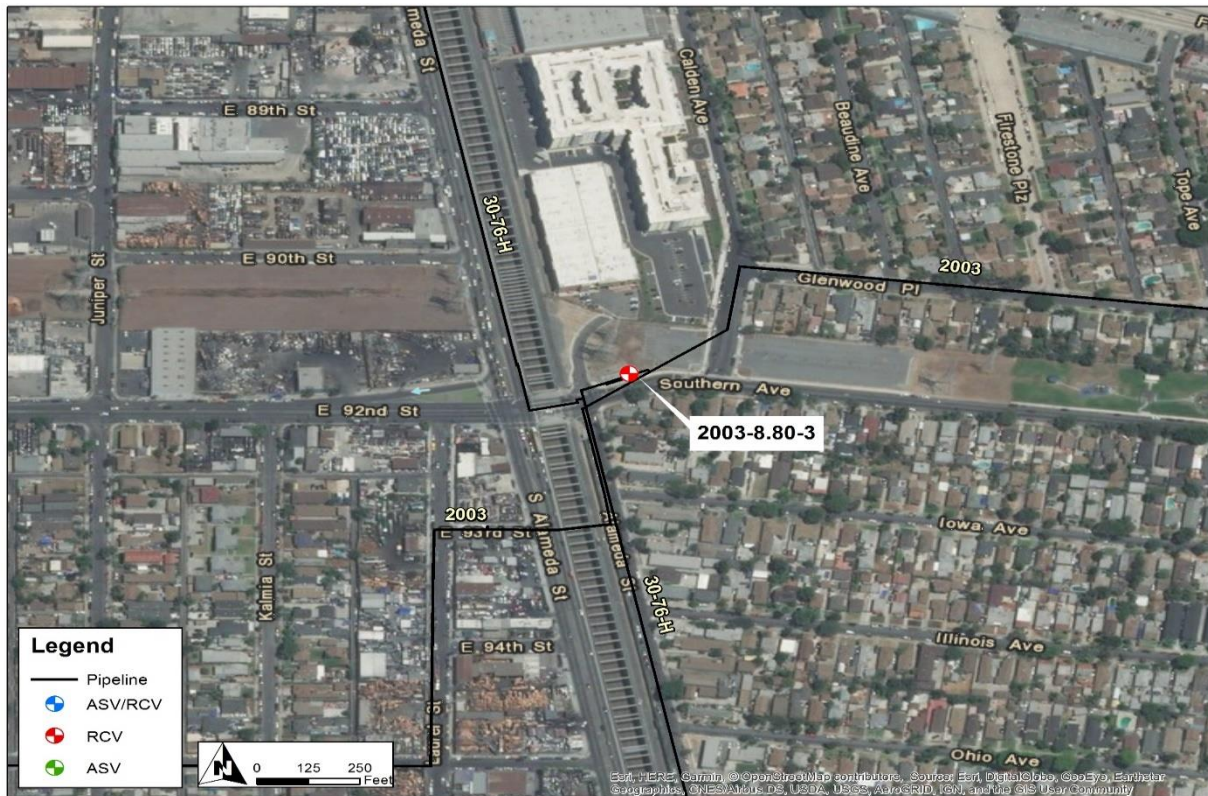

Pipeline Safety Enhancement Plan Final Report
Line 2003 East Valve Enhancement Project Bundle

II. ENGINEERING, DESIGN, AND PLANNING

A. Project Scope

SoCalGas and SDG&E presented a conceptual project scope in workpapers supporting the Valve Enhancement Plan¹ in the 2011 filing. This conceptual scope identified MLV 2003-5.56-0 for automation to provide remote isolation to portions of Line 2003. Prior to initiating execution of the Project, SoCalGas and SDG&E reviewed available information and performed a detailed system flow analysis to validate the scope of the Project. The final project scope is summarized in Table 2 below.

1. 2011 PSEP Filing: SoCalGas and SDG&E identified MLV 2003-5.56-0 for automation to achieve the objective of rapid system isolation.
2. Updated Scope: Upon project initiation, SoCalGas and SDG&E reviewed the conceptual project scope and determined that automation of MLV 2003-5.56-0 alone would not achieve the transmission isolation objectives set forth in the Valve Enhancement Plan. The Project Team determined that it was also necessary to install two check valves to prevent backflow to Line 2003 and to automate MLV 2003-0.78-0, crossover valves 2003-0.78-1 and 2003-0.78-2 and bridle valve 2003-8.80-3. Together, the automation of these five valves and the installation of two check valves enable rapid isolation, achieving Valve Enhancement Plan objectives.

¹ See Workpapers supporting Amended Pipeline Safety Enhancement Plan (PSEP) of SoCalGas and SDG&E, submitted on December 2, 2011, at WP-IX-2-14 through WP-IX-2-25 (A.11-11-002 Exh. # SCG-32).

Pipeline Safety Enhancement Plan Final Report
Line 2003 East Valve Enhancement Project Bundle

3. Engineering, Design, and Constructability:

- a. Mainline Valve 2003-5.56-0 is in the street and MLV 2003-5.94-0 is located near an existing SoCalGas facility. The Project Team determined that it would be more cost effective to automate MLV 2003-5.94-0, located in a Company facility, rather than MLV 2003-5.56-0 located in the street.
- b. The Project Team initially planned to automate valve 2003-8.80-0. This would have required extending the existing fencing and obtaining a new exclusive easement. Valve 2003-8.80-3 was inside the existing facility and automating this valve would achieve the same objective as automating valve 2003-8.80-0.

4. Final Project Scope: The final project scope consists of the automation of five valves that included the installation of four new actuators, the installation of two check valves at the Salt Lake Station and the installation of power equipment at two of the project sites, the installation of communications equipment at two of the project sites and the installation of the necessary automation equipment at the project sites.

Table 2: Final Project Scope

Final Project Scope					
Line	Mile	Valve #	Valve Size (<i>confidential</i>)	Installation Type	Function
2003	0.78	0	████████	A/AG	ASV/RCV
2003	0.78	1	████████	A/AG	RCV
2003	0.78	2	████████	A/AG	RCV
2003	5.94	0	████████	C/P	ASV/RCV
2003	5.94	N/A	████████	NV	BFP2
2003	5.94	N/A	████████	NV	BFP2
2003	8.80	3	████████	A/AG	RCV

Pipeline Safety Enhancement Plan Final Report
Line 2003 East Valve Enhancement Project Bundle

B. Site Evaluation and Planning

SoCalGas and SDG&E initiated the planning process for the Line 2003 East Valve Enhancement Project Bundle by performing a pre-design site walk to determine the existing conditions and assess any potential impacts on the design. Key factors that influenced the engineering and design of this project are as follows:

Slauson and Industry

1. Site Description: This project site is located inside of an equipment rental company's parking lot in a high-density area that is a mix of industrial and commercial businesses. There is sufficient space for construction activities and a laydown yard.
2. Land Issues: During the pre-design site walk, the Project Team noted that an exclusive easement would be required from the property owner. The Project Team also determined that the new equipment should be enclosed in a fence to increase the safety for the employees of the equipment rental company.
3. DOT Class: This project site is in a Class 3 Location.
4. Power Source: There was no preexisting power source, the Project Team installed new power equipment at the site.
5. Communication Technology: There was no preexisting communications equipment, the Project Team installed new communications equipment at the site.

Pipeline Safety Enhancement Plan Final Report
Line 2003 East Valve Enhancement Project Bundle

Salt Lake Station

1. Site Description: The site is an existing SoCalGas owned facility located in a high-density area that is a mix of industrial and residential neighborhood.
2. Land Issues: During the pre-design site walk, the Project Team noted that the existing facility can accommodate the new equipment.
3. DOT Class: This project site is in a Class 3 location.
4. Power Source: The site had existing utility power.
5. Communication Technology: The site had existing radio communications.

Southern and Alameda

1. Site Description: This site is an existing SoCalGas owned facility located in a residential area. There are transmission electrical lines north of the facility.
2. Land Issues: During the pre-design site walk, the Project Team noted that the existing facility can accommodate the new equipment.
3. DOT Class: This project site is in a Class 3 Location.
4. Power Source: There was no preexisting power source, the Project Team installed new power equipment at the site.
5. Communication Technology: There was no preexisting communications equipment, the Project Team installed new communications equipment at the site.

Pipeline Safety Enhancement Plan Final Report
Line 2003 East Valve Enhancement Project Bundle

C. Engineering, Design, and Planning Factors

SoCalGas and SDG&E reviewed drawings and records, contacted internal planning groups, communicated with external stakeholders, and completed a pre-design site walk. Key factors that influenced the engineering and design of the Project are as follows:

Slauson and Industry

1. Engineering Assessment: The Project Team confirmed the existing technology and verified the specifications of the valves. The Project Team determined that coordination was required with the Los Angeles County Department of Public Works to make sure that the placement of new equipment and shelter would not interfere with access to an existing sewer line.
2. Valve Details:
 - a. 2003-0.78-0: The existing valve was a manually operated Class 300 ball valve that the Project Team reused.
 - b. 2003-0.78-1: The existing valve was a manually operated Class 300 ball valve that the Project Team reused.
 - c. 2003-0.78-2: The existing valve was a manually operated Class 300 ball valve that the Project Team reused.
3. Actuator Details:
 - a. 2003-0.78-0: There was no preexisting actuator, the Project Team installed a new actuator.

Pipeline Safety Enhancement Plan Final Report
Line 2003 East Valve Enhancement Project Bundle

- b. 2003-0.78-1: There was no preexisting actuator, the Project Team installed a new actuator.
- c. 2003-0.78-2: There was no preexisting actuator, the Project Team installed a new actuator.
- 4. Customer Impact: The Project Team did not anticipate service disruptions to customers.
- 5. Community Impact: The Project Team coordinated with the property owner to minimize the impact of construction to the facility.
- 6. Substructures: The Project Team identified an existing sewer line. The Project was designed to incorporate the sewer line into the design.
- 7. Environmental: The Project Team did not identify any notable environmental concerns at the site. An environmental monitor performed spot checks during construction.
- 8. Permit Restrictions: The Project Team obtained a Flood Control District Permit from the Los Angeles County Department of Public Works.
- 9. Land Use: The Project Team obtained a Temporary Right of Entry (TRE) from the property owner for a laydown yard. The Project Team also obtained easements for the new power equipment, communications equipment, shelter, and fencing. The Project Team also worked with the owners of the two adjacent properties to obtain an electrical easement to access utility power.
- 10. Traffic Control: The Project Team did not identify any traffic control needs at the site. The Project Team coordinated with the property owner and current tenant to minimize the impact from construction on their daily activities.

Pipeline Safety Enhancement Plan Final Report
Line 2003 East Valve Enhancement Project Bundle

Salt Lake Station

1. Engineering Assessment: During the site evaluation, the Project Team confirmed the existing technology and verified that the station would accommodate the new equipment.
2. Valve Details: The existing valve was a manually actuated Class 300 ball valve that the Project Team reused.
3. Actuator Details: The existing actuator is a rotary piston double acting actuator that the Project Team reused.
4. Customer Impact: The Project Team installed the check valves without any disruption to customers. There are existing tap valves, 2003-5.94-13 and 2003-5.94-14, on the Supply Line 43-6203. A three-day shut-in was performed prior to the tie-in to verify that service would be maintained by other sources servicing the same supply line.
5. Community Impact: The Project Team did not anticipate any notable impacts to the community from this Project.
6. Substructures: The Project Team did not identify any existing substructures that affected the design and engineering at this site.
7. Environmental: The Project Team did not identify any notable environmental concerns at the site. An environmental monitor performed spot checks during construction.
8. Permit Restrictions: There were no special permits or permit restrictions for this project site.

Pipeline Safety Enhancement Plan Final Report
Line 2003 East Valve Enhancement Project Bundle

9. Land Use: The Project Team performed all work within the existing SoCalGas facility.
10. Traffic Control: The Project Team did not identify any traffic control needs at the site.

Southern and Alameda

1. Engineering Assessment: During the site evaluation, the Project Team confirmed the existing technology and verified that the station would accommodate the new equipment.
2. Valve Details: The existing valve was a manually operated Class 300 ball valve that the Project Team reused.
3. Actuator Details: There was no preexisting actuator, the Project Team installed a new actuator.
4. Customer Impact: The Project Team did not anticipate service disruptions to customers.
5. Community Impact: The Project Team did not anticipate any notable impacts to the community from this Project.
6. Substructures: The Project Team did not identify any existing substructures that affected the design and engineering at this site.
7. Environmental: The Project Team did not identify any environmental concerns at the site.

Pipeline Safety Enhancement Plan Final Report
Line 2003 East Valve Enhancement Project Bundle

8. Permit Restrictions: The Project Team obtained an electrical easement from the City of South Gate. The Project Team also obtained a traffic control permit to trench across Southern Avenue.
9. Land Use: The Project Team performed all work within the existing SoCalGas facility.
10. Traffic Control: The Project Team closed one lane on Alameda Street while excavating for the electrical trench. Signage and flagmen were utilized to direct traffic.

Pipeline Safety Enhancement Plan Final Report Line 2003 East Valve Enhancement Project Bundle

Figure 5: Line 2003 East Valve Enhancement Project Bundle Schematic

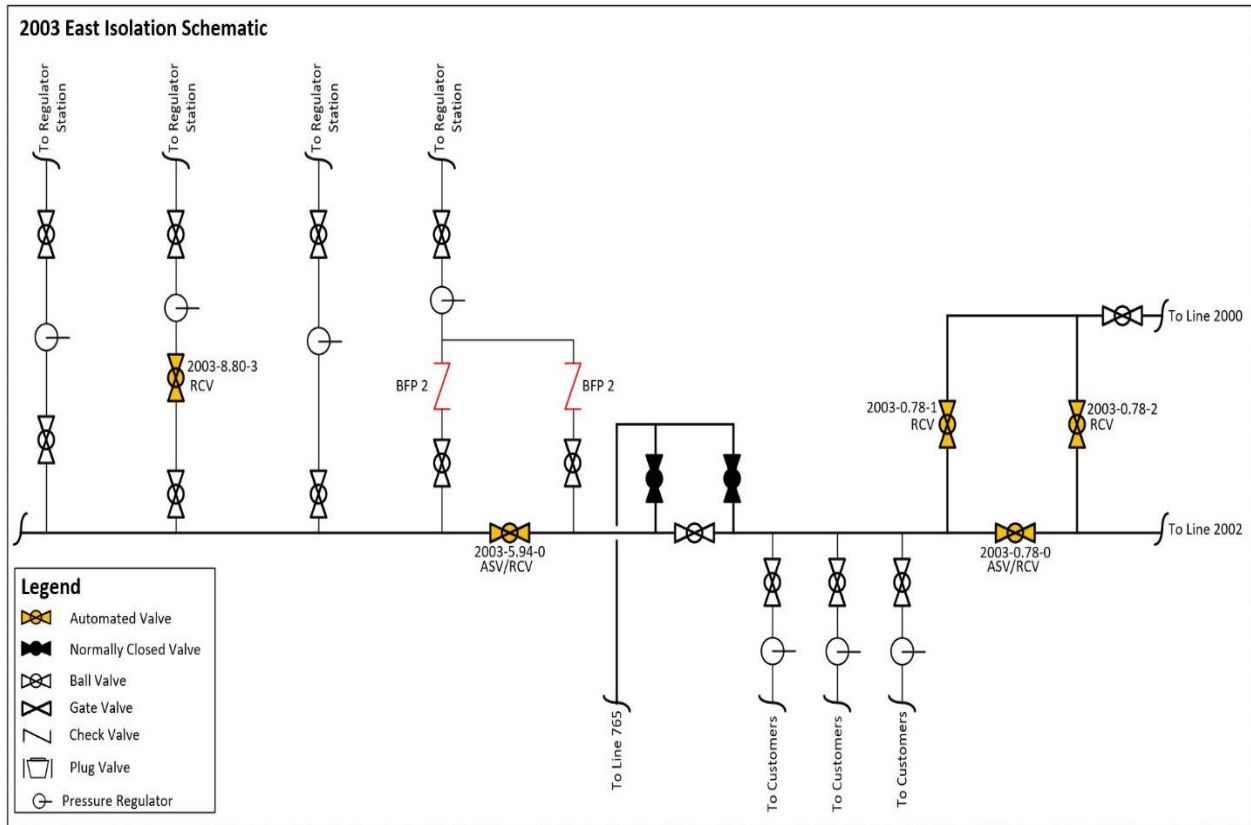

Pipeline Safety Enhancement Plan Final Report
Line 2003 East Valve Enhancement Project Bundle

D. Scope Changes

Through engineering, design, and planning activities, SoCalGas and SDG&E determined that changes in scope were appropriate to enhance the design of the Project and address engineering factors. The preliminary cost estimate does not fully reflect the final scope. After the creation of the preliminary estimate, the Project Team identified an existing sewer line at the Slauson and Industry site. The Project Team worked with the Los Angeles County Department of Public Works to make sure that the placement of new equipment and shelter would not interfere with access to an existing sewer line.

Pipeline Safety Enhancement Plan Final Report
Line 2003 East Valve Enhancement Project Bundle

III. CONSTRUCTION

A. Construction Contractor Selection

The Project Team prepared an initial cost estimate based on the preliminary design. Following completion of the engineering, design, and planning activities described above, the Project Team directed the Performance Partner (Mechanical Construction Contractor) and Alliance Partner (Electrical Contractor) area to prepare cost estimates based on a more detailed engineering design package, that included the updated design described in the discussion of notable changes in scope above.

1. SoCalGas and SDG&E's Preliminary Mechanical Construction Contractor Estimate (*confidential*): SoCalGas and SDG&E's preliminary cost estimate for construction was [REDACTED].
2. Mechanical Construction Contractor's Target Price Estimate (*confidential*): The Mechanical Construction Contractor's cost estimate was [REDACTED], which was [REDACTED] than SoCalGas and SDG&E's preliminary cost estimate for construction.
3. SoCalGas and SDG&E's Preliminary Electrical Contractor Estimate (*confidential*): SoCalGas and SDG&E's preliminary cost estimate for construction was [REDACTED].
4. Electrical Contractor's Estimate (*confidential*): The Electrical Contractor's estimate was [REDACTED], which was [REDACTED] than SoCalGas and SDG&E's preliminary cost estimate.

Pipeline Safety Enhancement Plan Final Report
Line 2003 East Valve Enhancement Project Bundle

B. Construction Schedule

Table 3: Construction Timeline

Slauson and Industry	
Construction Start Date	01/17/2017
Construction Completion Date	03/14/2017
Days on Site	61 days
Commissioning Date	10/04/2017
Salt Lake Station	
Construction Start Date	09/21/2015
Construction Completion Date	01/22/2016
Days on Site	54 days
Commissioning Date	03/10/2016
Southern and Alameda	
Construction Start Date	09/28/2015
Construction Completion Date	12/16/2015
Days on Site	42 days
Commissioning Date	09/26/2017

The Project Team completed all construction activities as soon as practicable prior to commissioning. SoCalGas and SDG&E’s finalization of commissioning activities is dependent on electrical utility connections, and system and/or resource availability.

C. Changes During Construction

SoCalGas and SDG&E successfully mitigated conditions during construction in a manner that minimized potential impacts on project scope, cost, and schedule. As a result, these conditions did not result in any notable change orders.

Pipeline Safety Enhancement Plan Final Report
Line 2003 East Valve Enhancement Project Bundle

Figure 6: Slauson and Industry – New Actuators in Foreground, New Linebreak Cabinet and RCV Cabinet in Background



Pipeline Safety Enhancement Plan Final Report
Line 2003 East Valve Enhancement Project Bundle

Figure 7: Salt Lake Station – Existing Actuator and New Instrument Gas Tubing



Pipeline Safety Enhancement Plan Final Report Line 2003 East Valve Enhancement Project Bundle

Figure 8: Southern and Alameda – New Actuator and Trenching for Station Grounding Installation



Pipeline Safety Enhancement Plan Final Report
Line 2003 East Valve Enhancement Project Bundle

D. Commissioning and Site Restoration

Commissioning activities included site restoration, final inspections, and placement of the valves into service. During this stage, SoCalGas and SDG&E successfully performed site acceptance testing and conducted point-to-point verification with SoCalGas Gas Control personnel for newly-automated valves. SoCalGas and SDG&E trained Field Operations personnel on the proper use and operation of the new equipment. Closeout activities included development of final drawings, the reconciliation package, and updates to company recordkeeping systems to reflect the completed scope of work. The sites were commissioned on March 10, 2016, September 26, 2017, and October 4, 2017, as summarized in Table 3.

Pipeline Safety Enhancement Plan Final Report
Line 2003 East Valve Enhancement Project Bundle

IV. PROJECT COSTS

A. Cost Avoidance Actions

SoCalGas and SDG&E exercised due diligence in the design, planning, and construction activities for this project to minimize or avoid costs when prudent to do so. The Project Team reviewed existing records, communicated with external stakeholders, and conducted a site walk to incorporate the known site conditions in the project plan and design. Specific examples of cost avoidance actions taken on this project were:

1. Planning and Coordination: SoCalGas and SDG&E bundled projects to coordinate construction activity between the three Line 2003 East Valve Enhancement Projects.
2. Land Use: The Project Team utilized the Salt Lake Station as a laydown yard for both Salt Lake Station site and the Southern and Alameda site.

B. Cost Estimates

Based on the preliminary design, once the preliminary project scope was confirmed and engineering, design, and planning activities were underway, SoCalGas and SDG&E prepared an estimate of the Direct Costs of the Project in the amount of \$2,597,760. This estimate was prepared in February of 2015, using the “Stage 3 SCG Valve Estimate Template Rev 1” estimating tool, the most current version of the PSEP Estimate Template at the time.

The Project Team considered the conditions known at the time to prepare the preliminary Direct Cost estimate. This estimate reflects the projected Labor, Material, and Services costs anticipated to be incurred to execute the Project, based on initial design plans.

Pipeline Safety Enhancement Plan Final Report
Line 2003 East Valve Enhancement Project Bundle

SoCalGas and SDGE estimated Indirect Costs of the Project based on the estimated Direct Costs and other project-related variables.

C. Actual Direct and Indirect Costs

Actual Direct Costs reflect the Labor, Material, and Services costs incurred to execute the Project. Actual Indirect Costs reflect costs for incremental overhead loaders in accordance with Company overhead allocation policies. The total loaded cost of the Project is \$4,436,317.

Table 4: Estimated and Actual Direct Costs and Variances

Direct Costs (\$)	Estimate	Actuals	Delta Over/(Under)
Company Labor	208,481	184,115	(24,366)
Materials	382,500	352,446	(30,054)
Mechanical Construction Contractor	714,661	585,292	(129,369)
Electrical Contractor	310,610	534,616	224,006
Construction Management & Support	132,841	294,218	161,377
Environmental	22,000	37,392	15,392
Engineering & Design	377,650	1,102,962	725,312
Project Management & Services	7,256	195,855	188,599
ROW & Permits	167,200	168,004	804
GMA	274,561	445,837	171,276
Total Direct Costs	2,597,760	3,900,737	1,302,977

Pipeline Safety Enhancement Plan Final Report
Line 2003 East Valve Enhancement Project Bundle

Table 5: Estimated and Actual Indirect Costs, Total Costs, and Variances

Indirect Costs/Total Costs (\$)	Estimate	Actuals	Delta Over/(Under)
Overheads	337,955	346,204	8,249
AFUDC	235,674	167,365	(68,309)
Property Taxes	50,045	22,011	(28,034)
Total Indirect Costs	623,674	535,580	(88,094)
Total Direct Costs	2,597,760	3,900,737	1,302,977
Total Loaded Costs	3,221,434	4,436,317	1,214,883

Pipeline Safety Enhancement Plan Final Report
Line 2003 East Valve Enhancement Project Bundle

V. CONCLUSION

SoCalGas and SDG&E enhanced the safety of their integrated natural gas system by prudently executing the Line 2003 East Valve Enhancement Project Bundle. Through this Valve Enhancement Project Bundle, SoCalGas and SDG&E successfully automated two mainline valves, three crossover valves, four actuators, and installed two check valves to achieve the objective of enabling rapid system isolation in the Cities of Pico Rivera, Cudahy, and South Gate. The total loaded cost of the Project is \$4,436,317.

SoCalGas and SDG&E executed this Project prudently through designing and executing the Project to support achievement of Valve Enhancement Plan isolation objectives; coordinating and bundling three valve projects into a comprehensive construction package to capture efficiencies through coordinated scheduling of construction crews; and installing equipment necessary to bring power and communication capabilities to two of the sites to enable rapid system isolation to portions of Line 2003 in Pico Rivera, Cudahy and South Gate.

SoCalGas and SDG&E engaged in prudent cost avoidance efforts to complete this safety enhancement work at a reasonable cost by carefully planning and coordinating construction activity, and by limiting the number of mobilizations across three different project sites to maximize efficiencies and reduce customer and community impacts.

End of Line 2003 East Valve Enhancement Project Bundle Final Report

Pipeline Safety Enhancement Plan Final Report
Line 2003 West Valve Enhancement Project Bundle

I. LINE 2003 WEST VALVE ENHANCEMENT PROJECT BUNDLE

A. Background and Summary

This report describes the activities associated with the Line 2003 Valve Enhancement Project Bundle, that consists of valve enhancements made to two existing mainline valves (MLVs) and the installation of four check valves in the Cities of Los Angeles, Compton, and in the unincorporated community of Los Angeles County. Through this project, SoCalGas and SDG&E enhanced the capabilities of two MLVs and installed four check valves to enable rapid transmission system isolation to a portion of Lines 2003, 2006, and 3007. SoCalGas and SDG&E installed two new actuators, two new vaults to house the actuators, four check valves, new power equipment, new communications equipment, and the necessary automation equipment at the sites. The total loaded project cost is \$3,929,959.

The valves comprising the Line 2003 West Valve Enhancement Project Bundle are in urban areas and are separated into three project sites. The LAX site is in the backlot of a rental car facility and services a private CNG station utilized by shuttle buses that operate between LAX and the facility. The Central Avenue and 142nd Street project site is in a parkway between South Central Avenue and a local residential access road. The Vermont Avenue and 102nd Street project site is within a median in the middle of Vermont Avenue. SoCalGas and SDG&E grouped the three project sites together into a single valve bundle and executed the three sites as a comprehensive package because the sites are geographically proximate and are locations where work could be performed simultaneously, such that the Project Team could manage the work load between project sites and capture efficiencies by limiting the number of mobilizations and demobilizations.

Pipeline Safety Enhancement Plan Final Report Line 2003 West Valve Enhancement Project Bundle

Table 1: General Project Information

Line 2003 West Valve Enhancement Project Bundle			
Site	LAX	Central & 142 nd	Vermont & 102 nd
Location	City of Los Angeles	City of Compton	Los Angeles County
Days on Site	15 days	42 days	60 days
Construction Start	10/21/2015	03/14/2016	08/01/2016
Construction Finish	12/03/2015	05/19/2016	11/02/2016
Commissioning Date	12/03/2015	10/10/2017	07/25/2017
Valve Upgrades			
Valve Number	N/A ¹	2006-3.06-0	2003-13.09-0
Valve Type	New – Check	Existing – Ball	Existing – Ball
Actuator	N/A	New	New
Actuator Above-/Below-Grade	N/A	Below-Grade	Below-Grade
ASV	N/A	Yes	Yes
RCV	N/A	Yes	Yes
Valve Number	N/A		N/A
Valve Type	New – Check		New – Check
Actuator	N/A		N/A
Actuator Above-/Below-Grade	N/A		Below-Grade
ASV	N/A		N/A
RCV	N/A		N/A
Valve Number			N/A
Valve Type			New – Check
Actuator			N/A
Actuator Above-/Below-Grade			Below-Grade
ASV			N/A
RCV			N/A
Site Upgrades			
Vault	None	New	New
Power	None	New – Utility	New – Utility
Communication	None	New – Radio	New – Radio
SCADA Panel	None	New	New
Equipment Shelter	None	None	None
Fencing	None	None	New – Fencing

¹ Check valves are not numbered.

Pipeline Safety Enhancement Plan Final Report
Line 2003 West Valve Enhancement Project Bundle

Table 1: General Project Information (Continued)

Project Costs (\$)	Capital	O&M	Total
Loaded Project Costs	3,929,959	-	3,929,959
Disallowed Costs	-	-	-

Pipeline Safety Enhancement Plan Final Report
Line 2003 West Valve Enhancement Project Bundle

B. Maps and Images

Figure 1: Satellite Image of Line 2003 West Valve Enhancement Project Bundle: Overview

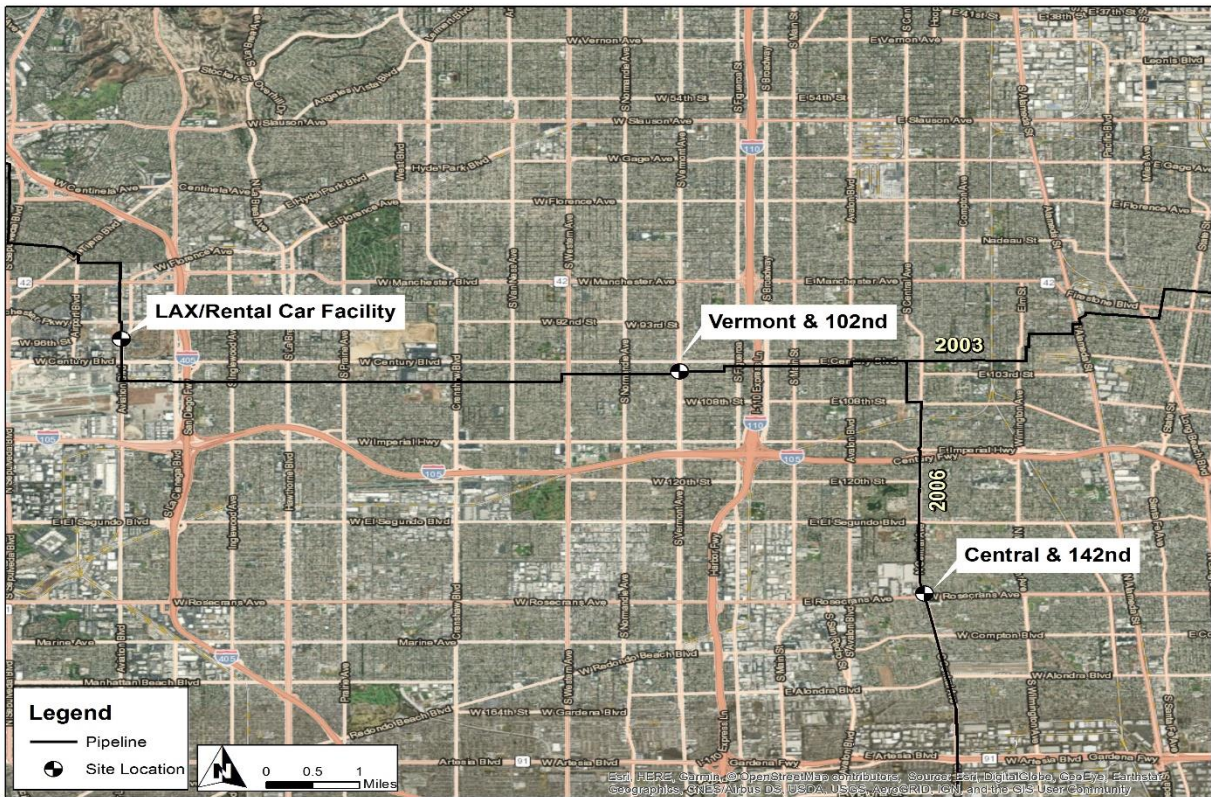

Pipeline Safety Enhancement Plan Final Report Line 2003 West Valve Enhancement Project Bundle

Figure 2: Satellite Image of LAX and Rental Car Facility



Pipeline Safety Enhancement Plan Final Report Line 2003 West Valve Enhancement Project Bundle

Figure 3: Satellite Image of Central Avenue and 142nd Street



Pipeline Safety Enhancement Plan Final Report Line 2003 West Valve Enhancement Project Bundle

Figure 4: Satellite Image of Vermont Avenue and 102nd Street



Pipeline Safety Enhancement Plan Final Report
Line 2003 West Valve Enhancement Project Bundle

II. ENGINEERING, DESIGN, AND PLANNING

A. Project Scope

SoCalGas and SDG&E presented a conceptual project scope in workpapers supporting the Valve Enhancement Plan² in the 2011 filing. This conceptual scope identified two MLVs, for automation to provide remote isolation to a portion of Lines 2003, 2006, and 3007. Prior to initiating execution of the Project, SoCalGas and SDG&E reviewed available information and performed a detailed system flow analysis to validate the scope of the Project. The resulted in the identification of four check valve installations to provide the planned isolation. The final project scope is summarized in Table 2 below.

1. 2011 PSEP Filing: SoCalGas and SDG&E identified MLVs 2003-13.09-0 and 2006-3.06-0 for automation to achieve the objective of rapid system isolation.
2. Updated Scope: Upon project initiation, SoCalGas and SDG&E reviewed the conceptual project scope and determined that automation of these MLVs alone would not achieve the transmission isolation objectives set forth in the Valve Enhancement Plan. The Project Team determined it was also necessary to install four check valves, two in a rental car facility on two taps that service a CNG station to prevent backflow on Lines 2003 and 3007, and two at the Vermont and 102nd site to prevent backflow on Line 2003. Together, automation of the two valves identified in the filing and installation of the four check valves enabled rapid isolation, achieving Valve Enhancement Plan objectives.

² See Workpapers supporting Amended Pipeline Safety Enhancement Plan (PSEP) of SoCalGas and SDG&E, submitted on December 2, 2011, at WP-IX-2-14 through WP-IX-2-25 (A.11-11-002 Exh. # SCG-32).

Pipeline Safety Enhancement Plan Final Report
Line 2003 West Valve Enhancement Project Bundle

3. Engineering, Design, and Constructability: During the pre-design site walk discussed below, The Project Team examined the option of automating valves 2003-10.98-3 and 2003-10.98-0 at the intersection of Century Boulevard and Clovis Avenue and the option of installing a new MLV at the intersection of Century Boulevard and Clovis Avenue. The Project Team determined that these options would be more expensive than automating the existing MLV 2006.3.06-0.

4. Final Project Scope: The final project scope consists of the automation of two MLVs, that included the installation of two new actuators, the installation of two new vaults to house the actuators, the installation of power equipment, the installation of communications equipment, the installation of the necessary automation equipment at the project sites, the installation of two check valves in the LAX rental car facility, and the installation of two check valves on Supply Line 2003 ID2040-P.

Table 2: Final Project Scope

Final Project Scope					
Line	Mile	Valve #	Valve Size (<i>confidential</i>)	Installation Type	Function
2003	13.09	0	██████████	A/VT	ASV/RCV
2006	3.06	0	██████████	A/VT	ASV/RCV
2003	13.09	N/A	██████████	NV	BFP2
2003	13.09	N/A	██████████	NV	BFP2
2003	18.78	N/A	██████████	NV	BFP2
3007	3.87	N/A	██████████	NV	BFP2

Pipeline Safety Enhancement Plan Final Report
Line 2003 West Valve Enhancement Project Bundle

B. Site Evaluation and Planning

SoCalGas and SDG&E initiated the planning process for the Line 2003 West Valve Enhancement Project Bundle by performing pre-design site walks to determine the existing conditions and assess any potential impacts on the design. Key factors that influenced the engineering and design of this project are as follows:

LAX-Rental Car Facility

1. Site Description: This project site is in the backlot of an LAX rental car facility and services a private CNG station utilized by shuttle busses that operate between LAX and the CNG facility.
2. Land Issues: During the pre-design site walk, the Project Team noted that the rental car facility controls access to the site and must open the gate for equipment to reach the site in pursuant to the terms of SoCalGas' right of way agreements.
3. DOT Class: The site is a Class 3 location.
4. Power Source: The scope of work for this project site did not require any power equipment.
5. Communication Technology: The scope of work for this project site did not require any communications equipment.

Central and 142nd

1. Site Description: The project site is in a residential and commercial area. The valve is in a parkway between South Central Avenue and a local residential access road, and the residential access road is lined with houses. The valve is oriented on its side underneath the parkway.

Pipeline Safety Enhancement Plan Final Report
Line 2003 West Valve Enhancement Project Bundle

2. Land Issues: During the pre-design site walk, the Project Team noted that the residents will need to be notified prior to construction and that traffic control will be required during construction.
3. DOT Class: The site is in a Class 3 location.
4. Power Source: There was no preexisting power source, the Project Team installed new power equipment at the site.
5. Communication Technology: There was no preexisting communications equipment, the Project Team installed new communications equipment at the site.

Vermont and 102nd

1. Site Description: The site is in a high density residential area in the median of Vermont Avenue. The valve is buried in a median and is orientated on its side.
2. Land Issues: The Project Team noted that the new equipment should be enclosed in fencing. The Project Team identified one tree that is in the work space. The Project Team determined that traffic control will be required during construction.
3. DOT Class: The site is in a Class 3 location.
4. Power Source: There was no preexisting power source, the Project Team installed new power equipment at the site.
5. Communication Technology: There was no preexisting communications equipment, the Project Team installed new communications equipment at the site.

Pipeline Safety Enhancement Plan Final Report
Line 2003 West Valve Enhancement Project Bundle

C. Engineering, Design, and Planning Factors

SoCalGas and SDG&E reviewed drawings and records, contacted internal planning groups, communicated with external stakeholders, conducted survey activity, performed potholing to verify the existing technology, and completed a pre-design site walk. Key factors that influenced the engineering and design of the Project are as follows:

LAX-Rental Car Facility

1. Engineering Assessment: The Project Team noted that this work required a shut-in of the regulator station servicing the CNG station. Service was maintained to the CNG station via a bypass.
2. Valve Details: There were no preexisting check valves.
3. Actuator Details: The scope of work for this project site did not require the installation of an actuator.
4. Customer Impact: The Project Team noted that this work required a shut-in of the regulator station servicing the CNG station. Service was maintained to the CNG station via a bypass.
5. Community Impact: The Project Team coordinated with the rental car facility to gain access to the project site during construction.
6. Substructures: The Project Team did not identify any existing substructures that affected the design and engineering at this site.
7. Environmental: The Project Team did not identify any notable environmental concerns at the site. An environmental monitor performed spot checks during construction.

Pipeline Safety Enhancement Plan Final Report
Line 2003 West Valve Enhancement Project Bundle

8. Permit Restrictions: There were no special permits or permit restrictions for this project site.
9. Land Use: There was sufficient space within the rental car facility for a laydown yard.
10. Traffic Control: The Project Team did not identify any traffic control needs at the site.

Central and 142nd

1. Engineering Assessment: The Project Team confirmed the preexisting technology and verified the specifications of the valve. There were no engineering items of note that impacted the design.
2. Valve Details: The existing valve was a manually operated Class 300 ball valve that the Project Team reused.
3. Actuator Details: There was no preexisting actuator, the Project Team installed a new actuator.
4. Customer Impact: The Project Team did not anticipate service disruptions to customers.
5. Community Impact: The Project Team notified the residents prior to construction. The Project Team made efforts to minimize the impact to the community from this project.
6. Substructures: The Project Team did not identify any existing substructures that affected the design and engineering at this site.

Pipeline Safety Enhancement Plan Final Report
Line 2003 West Valve Enhancement Project Bundle

7. Environmental: The Project Team did not identify any notable environmental concerns at the site. An environmental monitor performed spot checks during construction.
8. Permit Restrictions: The Project Team obtained a Utility Excavation Permit from the Department of Public Works for Los Angeles County for the excavation required for the installation of the new vault, the automation equipment, and the communications equipment. SoCalGas and SDG&E also requested a permit from the City of Compton to complete the boring required to install the conduit from the local utility transformer to the utility meter pedestal. This permit was denied so SoCalGas and SDG&E utilized trenching to install the conduit.
9. Land Use: There was sufficient space at the construction site for a laydown yard within the public right of way.
10. Traffic Control: The Project Team closed entry to the local access road parallel to South Central Avenue from one end for the duration of construction during construction hours. The Project Team obtained power from the local electric utility. The utility power access point was across the street from the project site on the opposite side of Central Avenue and the Project Team closed multiple lanes during trenching activities. The lanes were closed in stages to allow for continuous traffic flow during construction.

Vermont and 102nd

1. Engineering Assessment: The existing mainline valve is 10 feet 8 inches deep. Due to the depth and the orientation of the valve, the Project Team designed a custom actuator.

Pipeline Safety Enhancement Plan Final Report
Line 2003 West Valve Enhancement Project Bundle

2. Valve Details: The existing valve was a manually operated Class 300 ball valve that was reused.
3. Actuator Details: There was no preexisting actuator, the Project Team installed a new actuator.
4. Customer Impact: Regulator station ID1040-P was shut-in during the blowdown. The Project Team avoided the need for CNG or LNG by performing the blowdown and tie-in during summer conditions.
5. Community Impact: The Project Team notified the residents prior to construction. The Project Team made efforts to minimize the impact of construction.
6. Substructures: The Project Team did not identify any existing substructures that affected the design and engineering at this site.
7. Environmental: The Project Team did not identify any notable environmental concerns at the site. An environmental monitor performed spot checks during construction.
8. Permit Restrictions: The Project Team obtained an electrical permit from Los Angeles County.
9. Land Use: There was sufficient space at the construction site for a laydown yard within the public right of way.
10. Traffic Control: The Project Team obtained power from the local electric utility. The utility power access point was across the street from the project site on the opposite side of Vermont Avenue and the Project Team closed multiple southbound lanes during trenching activities. The lanes were closed in stages to allow for continuous traffic flow during construction.

Pipeline Safety Enhancement Plan Final Report Line 2003 West Valve Enhancement Project Bundle

Figure 5: Line 2003 West Valve Enhancement Project Bundle Schematic

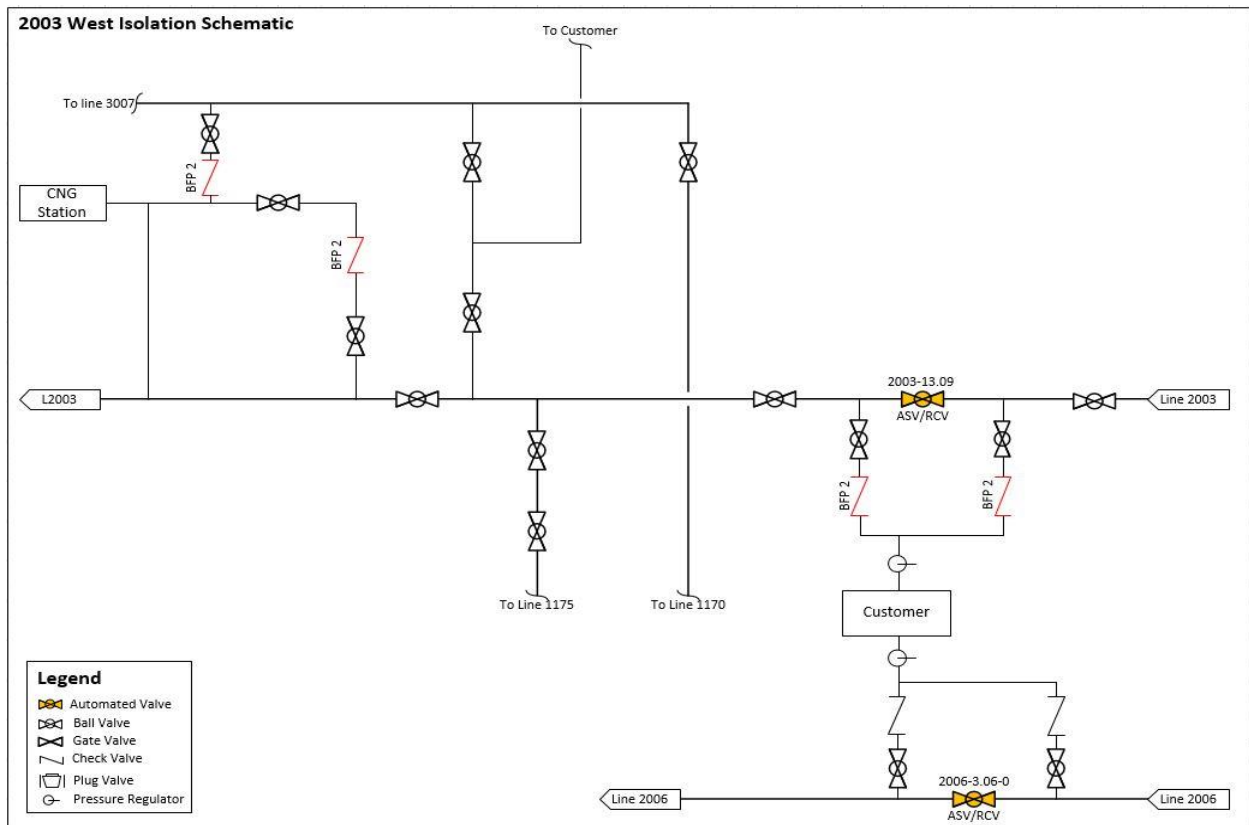

Pipeline Safety Enhancement Plan Final Report
Line 2003 West Valve Enhancement Project Bundle

D. Scope Changes

Through engineering, design, and planning activities, SoCalGas and SDG&E determined that changes in scope were appropriate to enhance the design of the Project and address engineering factors. As a result, the preliminary cost estimate does not fully reflect the final scope. SoCalGas and SDG&E initially planned to install two check valves on a bridle tap to Supply Line 30-6209-A-ST-1 at the Central and 142nd site to provide backflow prevention. SoCalGas and SDG&E determined that one of the two taps leading to the supply line was abandoned and therefore, the check valves were not required. SoCalGas and SDG&E included the installation costs of these check valves in the estimate.

Pipeline Safety Enhancement Plan Final Report
Line 2003 West Valve Enhancement Project Bundle

III. CONSTRUCTION

A. Construction Contractor Selection

The Project Team prepared an initial cost estimate based on the preliminary design. Following completion of the engineering, design, and planning activities described above, the Project Team directed the Performance Partner (Mechanical Construction Contractor) and Alliance Partner (Electrical Contractor) to prepare cost estimates based on a more detailed engineering design package, that included the updated design described in the discussion of notable changes to the scope above.

1. SoCalGas and SDG&E's Preliminary Mechanical Construction Contractor Estimate (confidential): SoCalGas and SDG&E's preliminary cost estimate for construction was [REDACTED].
2. Mechanical Construction Contractor's Target Price Estimate (confidential): The Mechanical Construction Contractor's cost estimate was [REDACTED], which was [REDACTED] less than SoCalGas and SDG&E's preliminary cost estimate for construction.
3. SoCalGas and SDG&E's Preliminary Electrical Contractor Estimate (confidential): SoCalGas and SDG&E's preliminary cost estimate for construction was [REDACTED].
4. Electrical Contractor's Estimate (confidential): The Electrical Contractor's estimate was [REDACTED], which was [REDACTED] than SoCalGas and SDG&E's preliminary cost estimate.

Pipeline Safety Enhancement Plan Final Report
Line 2003 West Valve Enhancement Project Bundle

B. Construction Schedule

Table 3: Construction Timeline

LAX	
Construction Start Date	10/21/2015
Construction Completion Date	12/03/2015
Days on Site	15 days
Commissioning Date	12/03/2015
Central and 142nd	
Construction Start Date	03/14/2016
Construction Completion Date	05/19/2016
Days on Site	42 days
Commissioning Date	10/10/2017
Vermont and 102nd	
Construction Start Date	08/01/2016
Construction Completion Date	11/02/2016
Days on Site	60 days
Commissioning Date	07/25/2017

SoCalGas and SDG&E completed all construction activities as soon as practicable prior to commissioning. Commissioning was delayed at the Central and 142nd site and at the Vermont and 102nd sites while the local electrical utility completed the activities necessary to provide service

C. Changes During Construction

SoCalGas and SDG&E successfully mitigated conditions during construction in a manner that minimized potential impacts on project scope, cost, and schedule. As a result, these conditions did not result in any notable change orders.

Pipeline Safety Enhancement Plan Final Report
Line 2003 West Valve Enhancement Project Bundle

Figure 6: Central Avenue and 142nd Street Project Site - Post Construction
SCADA Cabinet and Battery Enclosure in Foreground, Linebreak Cabinet in Background



Pipeline Safety Enhancement Plan Final Report
Line 2003 West Valve Enhancement Project Bundle

Figure 7: Vermont Avenue and 102nd Street –
New Blowdown Assembly Prior to Installation



Pipeline Safety Enhancement Plan Final Report
Line 2003 West Valve Enhancement Project Bundle

D. Commissioning and Site Restoration

Commissioning activities included site restoration, final inspections, and placement of the valves back into service. During this stage, SoCalGas and SDG&E successfully performed site acceptance testing and conducted point-to-point verification with SoCalGas Gas Control personnel for the newly-automated valves. SoCalGas and SDG&E trained Field Operations personnel on the proper use and operation of the new equipment. Closeout activities included development of final drawings, the reconciliation package and updates to company recordkeeping systems to reflect the completed scope of work. The sites were commissioned on December 3, 2015, July 25, 2017, and October 10, 2017, as summarized in Table 3.

Pipeline Safety Enhancement Plan Final Report
Line 2003 West Valve Enhancement Project Bundle

IV. PROJECT COSTS

A. Cost Avoidance Actions

SoCalGas and SDG&E exercised due diligence in the design, planning, and construction activities for this project to minimize or avoid costs when prudent to do so. As discussed above, the Project Team reviewed existing records, communicated with external stakeholders and conducted pre-design site walks to incorporate the known site conditions in the project plan and design. Specific examples of cost avoidance actions taken on this project were:

1. Planning and Coordination: The Project Team bundled the Line 2003 West projects to coordinate engineering activities between the three project sites.
2. Engineering and Design: The Project Team initially proposed to automate valves at the intersection of South Central Avenue and Clovis Avenue. The Project Team determined that automating valves at this location would be costlier and would create a significant impact on the community. The Project Team determined that MLV 2006-3.09-0 at South Central Avenue and 142nd Street was a better option for automation while still achieving the same objective of enabling rapid system isolation.

Pipeline Safety Enhancement Plan Final Report
Line 2003 West Valve Enhancement Project Bundle

B. Cost Estimates

Based on the preliminary design, once the preliminary project scope was confirmed and engineering, design, and planning activities were underway, SoCalGas and SDG&E prepared an estimate of the Direct Costs of the Project in the amount of \$2,358,183. This estimate was prepared in February of 2015, using the “Stage 3 SCG Valve Estimate Template Rev 1” estimating tool, the most current version of the PSEP Estimate Template at the time. The Project Team considered the conditions known at the time to prepare the preliminary Direct Cost estimate. This estimate reflects the projected Labor, Material and Services costs anticipated to be incurred to execute the Project, based on initial design plans.

SoCalGas and SDG&E estimated Indirect Costs of the Project based on the estimated Direct Costs and other project-related variables.

C. Actual Direct and Indirect Costs

Actual Direct Costs reflect the Labor, Material, and Services costs incurred to execute the Project. Actual Indirect Costs reflect costs for incremental overhead loaders in accordance with Company overhead allocation policies. The total loaded cost of the Project is \$3,929,959.

Pipeline Safety Enhancement Plan Final Report
Line 2003 West Valve Enhancement Project Bundle

Table 4: Estimated and Actual Direct Costs and Variances

Direct Costs (\$)	Estimate	Actuals	Delta Over/(Under)
Company Labor	208,582	175,248	(33,334)
Materials	354,757	309,549	(45,208)
Mechanical Construction Contractor	859,440	757,381	(102,059)
Electrical Contractor	148,370	446,059	297,689
Construction Management & Support	187,891	244,220	56,329
Environmental	-	27,574	27,574
Engineering & Design	337,694	918,680	580,986
Project Management & Services	7,261	130,882	123,621
ROW & Permits	4,950	31,497	26,547
GMA	249,238	394,692	145,454
Total Direct Costs	2,358,183	3,435,782	1,077,599

Table 5: Estimated and Actual Indirect Costs, Total Costs, and Variances

Indirect Cost/Total Costs (\$)	Estimate	Actuals	Delta Over/(Under)
Overheads	323,595	328,500	4,905
AFUDC	217,548	146,314	(71,234)
Property Taxes	46,196	19,363	(26,833)
Total Indirect Costs	587,339	494,177	(93,162)
Total Direct Costs	2,358,183	3,435,782	1,077,599
Total Loaded Costs	2,945,522	3,929,959	984,437

Pipeline Safety Enhancement Plan Final Report
Line 2003 West Valve Enhancement Project Bundle

V. CONCLUSION

SoCalGas and SDG&E enhanced the safety of their integrated natural gas system by prudently executing the Line 2003 West Valve Enhancement Project Bundle. Through this Valve Enhancement Project Bundle, SoCalGas and SDG&E successfully automated two mainline valves and installed four check valves to achieve the objective of enabling rapid system isolation in the Los Angeles County, the City of Los Angeles, and the City of Compton. The total loaded cost of the Project is \$3,929,959.

SoCalGas and SDG&E executed this Project prudently through designing and executing the Project to support achievement of Valve Enhancement Plan isolation objectives, coordinating and bundling three valve projects into a comprehensive construction package to capture efficiencies through coordinated scheduling of construction crews, and installing equipment necessary to bring power and communication capabilities to two of the sites to enable rapid system isolation to portions of Lines 2003, 2006, and 3007 in Los Angeles County, the City of Los Angeles, and the City of Compton.

SoCalGas and SDG&E engaged in prudent cost avoidance efforts to complete this safety enhancement at a reasonable cost by carefully planning and coordinating construction activity, and by limiting the number of mobilizations across three different project sites to maximize efficiencies and reduce customer and community impacts.

End of Line 2003 West Valve Enhancement Project Bundle

Pipeline Safety Enhancement Plan Final Report
Line 225 Valve Enhancement Project Bundle

I. LINE 225 VALVE ENHANCEMENT PROJECT BUNDLE

A. Background and Summary

This report describes the activities associated with the Line 225 Valve Enhancement Project Bundle, that consists of valve enhancements made to two existing mainline valves (MLVs), and the installation of a check valve in the City of Arvin and in the unincorporated community of Lebec in Kern County. Through this project, SoCalGas and SDG&E enhanced the capabilities of two MLVs to enable rapid transmission system isolation to portions of Line 225 and Supply Line 44-623. SoCalGas and SDG&E installed a new actuator, a new check valve, new power equipment, new communications equipment, and the necessary automation equipment at the sites. The total loaded project cost is \$2,574,554.

The valves comprising the Line 225 Valve Enhancement Project Bundle are in rural areas and are separated into three project sites. The A Street site is an existing SoCalGas facility at the edge of an orchard. The Laval Road site is an existing SoCalGas facility in an open field next to Laval Road, there is a commercial building nearby. The Edmonston site is an existing SoCalGas facility in an open area next to Edmonston Pumping Plant Road. SoCalGas and SDG&E grouped the three project sites together into a single valve bundle and executed the three sites as a comprehensive package because the sites are geographically proximate.

Pipeline Safety Enhancement Plan Final Report Line 225 Valve Enhancement Project Bundle

Table 1: General Project Information

Line 225 Valve Enhancement Project Bundle			
Site	A Street	Laval Road	Edmonston
Location	Arvin	Arvin	Lebec
Days on Site	7 days	25 days	49 days
Construction Start	08/08/2016	08/22/2016	11/14/2016
Construction Finish	08/18/2016	09/26/2016	02/08/2017
Commissioning Date	08/18/2016	06/15/2017	06/14/2017
Valve Upgrades			
Valve Number	N/A	225-29.68-0	225-33.25-0
Valve Type	New – Check	Existing – Ball	Existing – Ball
Actuator	N/A	Existing	New
Actuator Above-/Below-Grade	N/A	Above	Above
ASV	N/A	Yes	Yes
RCV	N/A	Yes	Yes
Site Upgrades			
Vault	None	None	None
Power	N/A	New – Utility	New – Solar
Communication	N/A	New – Radio	New – Radio
SCADA Panel	N/A	New	New
Equipment Shelter	None	None	None
Fencing	Existing	Existing	Expanded
Project Costs (\$)	Capital	O&M	Total
Loaded Project Costs	2,574,554	-	2,574,554
Disallowed Costs	-	-	-

Pipeline Safety Enhancement Plan Final Report
Line 225 Valve Enhancement Project Bundle

B. Maps and Images

Figure 1: Satellite Image of Line 225 Valve Enhancement Project Bundle: Overview

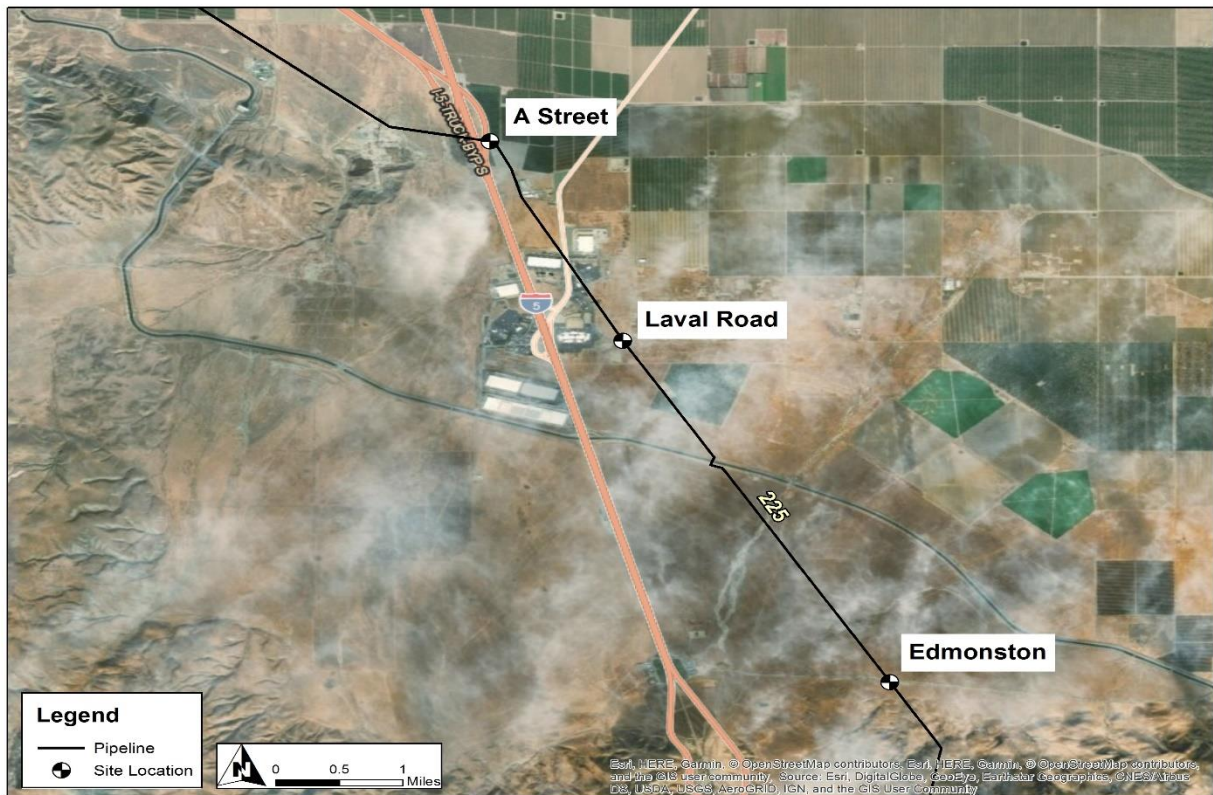

Pipeline Safety Enhancement Plan Final Report
Line 225 Valve Enhancement Project Bundle

Figure 2: A Street



Pipeline Safety Enhancement Plan Final Report Line 225 Valve Enhancement Project Bundle

Figure 3: Laval Road



Pipeline Safety Enhancement Plan Final Report Line 225 Valve Enhancement Project Bundle

Figure 4: Edmonston



Pipeline Safety Enhancement Plan Final Report
Line 225 Valve Enhancement Project Bundle

II. ENGINEERING, DESIGN, AND PLANNING

A. Project Scope

SoCalGas and SDG&E presented a conceptual project scope in workpapers supporting the Valve Enhancement Plan¹ in the 2011 filing. This conceptual scope identified MLV 225-29.68-0, for automation to provide remote isolation to a portion of Line 225. Prior to initiating execution of the Project, SoCalGas and SDG&E reviewed available information and performed a detailed system flow analysis to validate the scope of the Project. This resulted in the identification of an additional valve for enhancement and a check valve installation to provide the planned isolation. The final project scope is summarized in Table 2 below.

1. 2011 PSEP Filing: SoCalGas and SDG&E identified MLV 225-29.68-0 for automation to achieve the objective of rapid system isolation.
2. Updated Scope: Upon project initiation, SoCalGas and SDG&E reviewed the conceptual project scope and determined that the automation of this valve lone would not achieve the transmission isolation objectives set forth in the Valve Enhancement Plan. The Project Team determined it was also necessary to automate MLV 225-33.25-0, and install a check valve to prevent backflow on Line 225. this isolation point would achieve the transmission isolation objectives set forth in the Valve Enhancement Plan. Together, the automation of these two vavles and the installation of the check valve enabled rapid isolation, thereby achieving Valve Enhancement Plan objectives.

¹ See Workpapers supporting Amended Pipeline Safety Enhancement Plan (PSEP) of SoCalGas and SDG&E, submitted on December 2, 2011, at WP-IX-2-14 through WP-IX-2-25 (A.11-11-002 Exh. # SCG-32).

Pipeline Safety Enhancement Plan Final Report
Line 225 Valve Enhancement Project Bundle

3. Engineering, Design, and Constructability: No notable engineering adjustments were required to the standard design.
4. Final Project Scope: The final project scope consists of the automation of two valves, that included installation of one new actuator, the installation of power equipment, the installation of communications equipment, and the installation of the necessary automation equipment at the project sites, and the installation of one new check valve.

Table 2: Final Project Scope

Final Project Scope					
Line	Mile	Valve #	Valve Size (<i>confidential</i>)	Installation Type	Function
225	29.68	0	████████	C/P	ASV/RCV
225	33.25	0	████████	A/AG	ASV/RCV
44-623	0	N/A	████████	NV	BFP2

B. Site Evaluation and Planning

SoCalGas and SDG&E initiated the planning process for the Line 225 Valve Enhancement Project Bundle by performing pre-design site walks to determine the existing conditions and assess any potential impacts on the design. Key factors that influenced the engineering and design of this project are as follows:

A Street

1. Site Description: This site is an existing SoCalGas facility on A Street near the City of Arvin. The site is at the edge of an orchard.

Pipeline Safety Enhancement Plan Final Report
Line 225 Valve Enhancement Project Bundle

2. Land Issues: During the pre-design site walk, the Project Team noted that the existing facility can accommodate the new equipment.
3. DOT Class: This project site is in a Class 1 location. SoCalGas and SDG&E installed this check valve for backflow prevention to Line 225.
4. Power Source: There was no preexisting power source; however, the scope of work for this project site did not require any power equipment.
5. Communication Technology: There was no preexisting communications source; however, the scope of work for this project site did not require any communications equipment.

Laval Road

1. Site Description: This site is an existing SoCalGas facility on Laval Road near the City of Arvin. The site is in an open field near farmland.
2. Land Issues: During the pre-design site walk, the Project Team noted that the existing facility can accommodate the new equipment.
3. DOT Class: This project is in a Class 1 location. SoCalGas and SDG&E selected this MLV for automation to isolate a Class 3 HCA location upstream of this valve, and a geological thread downstream of this valve.
4. Power Source: The scope of work for this project site did not require any power equipment.
5. Communication Technology: The scope of work for this project site did not require any communications equipment.

Pipeline Safety Enhancement Plan Final Report
Line 225 Valve Enhancement Project Bundle

Edmonston

1. Site Description: This site is an existing SoCalGas facility in a rural area on Edmonston Pumping Plant Road.
2. Land Issues: During the pre-design site walk, the Project Team noted that the existing station would need to be expanded to accommodate the additional equipment.
3. DOT Class: This project is in a Class 1 location. SoCalGas and SDG&E selected this MLV for automation to isolate a geological thread upstream of this valve.
4. Power Source: There was no preexisting power source, the Project Team installed new power equipment at the site.
5. Communication Technology: There was no preexisting communications equipment, the Project Team installed new communications equipment at the site.

C. Engineering, Design, and Planning Factors

SoCalGas and SDG&E reviewed drawings and records, contacted internal planning groups, communicated with external stakeholders, conducted survey activity, and completed a pre-design site walk. Key factors that influenced the engineering and design of the Project are as follows:

A Street

1. Engineering Assessment: The scope of work for this project required a shut-in of Line 225 and Supply Line 44-623, there were no disruptions to customers.
2. Valve Details: There were no preexisting check valves.

Pipeline Safety Enhancement Plan Final Report
Line 225 Valve Enhancement Project Bundle

3. Actuator Details: The scope of work for this project site did not require the installation of an actuator.
4. Customer Impact: The Project Team did not anticipate service disruptions to customers.
5. Community Impact: The Project Team did not anticipate any notable impacts to the community from this project.
6. Substructures: The Project Team did not identify any existing substructures that affected the design and engineering at this site.
7. Environmental: The Project Team completed a biological survey for the blunt nosed leopard lizard and the San Joaquin kit fox prior to construction activities and did not identify any notable environmental concerns at the site. An environmental monitor performed spot checks during construction.
8. Permit Restrictions: There were no special permits or permit restrictions for this project site.
9. Land Use: The Project Team performed all work within the existing easement.
10. Traffic Control: The Project Team did not identify any traffic control needs at the site.

Laval Road

1. Engineering Assessment: The Project Team did not identify any engineering items of note.
2. Valve Details: The existing valve was a manually actuated Class 400 ball valve that the Project Team reused.

Pipeline Safety Enhancement Plan Final Report
Line 225 Valve Enhancement Project Bundle

3. Actuator Details: The existing actuator was a double-acting pneumatic actuator that the Project Team reused.
4. Customer Impact: The Project Team did not anticipate service disruptions to customers.
5. Community Impact: The Project Team did not anticipate any notable impacts to the community from this project.
6. Substructures: The Project Team did not identify any existing substructures that affected the design and engineering at this site.
7. Environmental: The Project Team completed a biological survey for the blunt nosed leopard lizard and the San Joaquin kit fox prior to construction activities and did not identify any notable environmental concerns at the site. An environmental monitor performed spot checks during construction.
8. Permit Restrictions: The Project Team obtained an electrical permit from Kern County.
9. Land Use: The Project Team performed all work within the existing easement.
10. Traffic Control: The Project Team did not identify any traffic control needs at the site.

Edmonston

1. Engineering Assessment: During the site evaluation, the Project Team confirmed the existing technology and verified the need to expand the existing station, to accommodate the new equipment.

Pipeline Safety Enhancement Plan Final Report
Line 225 Valve Enhancement Project Bundle

2. Valve Details: The existing valve is a manually actuated Class 600 ball valve that the Project Team reused.
3. Actuator Details: The preexisting actuator was incompatible with PSEP linebreak technology, the Project Team installed a new actuator.
4. Customer Impact: The Project Team did not anticipate service disruptions to customers.
5. Community Impact: The Project Team did not anticipate any notable impact to the community from this project.
6. Substructures: The Project Team did not identify any existing substructures that affected the design and engineering at this site.
7. Environmental: The Project Team completed a biological survey for the blunt nosed leopard lizard and the San Joaquin kit fox prior to construction activities and did not identify any notable environmental concerns at the site. An environmental monitor performed spot checks during construction.
8. Permit Restrictions: There were no special permits or permit restrictions for this project site.
9. Land Use: The Project Team expanded the existing facility to accommodate the new automation equipment. The Project Team performed all work within the existing easement.
10. Traffic Control: The Project Team did not identify any traffic control needs at the site.

Pipeline Safety Enhancement Plan Final Report Line 225 Valve Enhancement Project Bundle

Figure 5: Line 225 Valve Enhancement Project Bundle Schematic

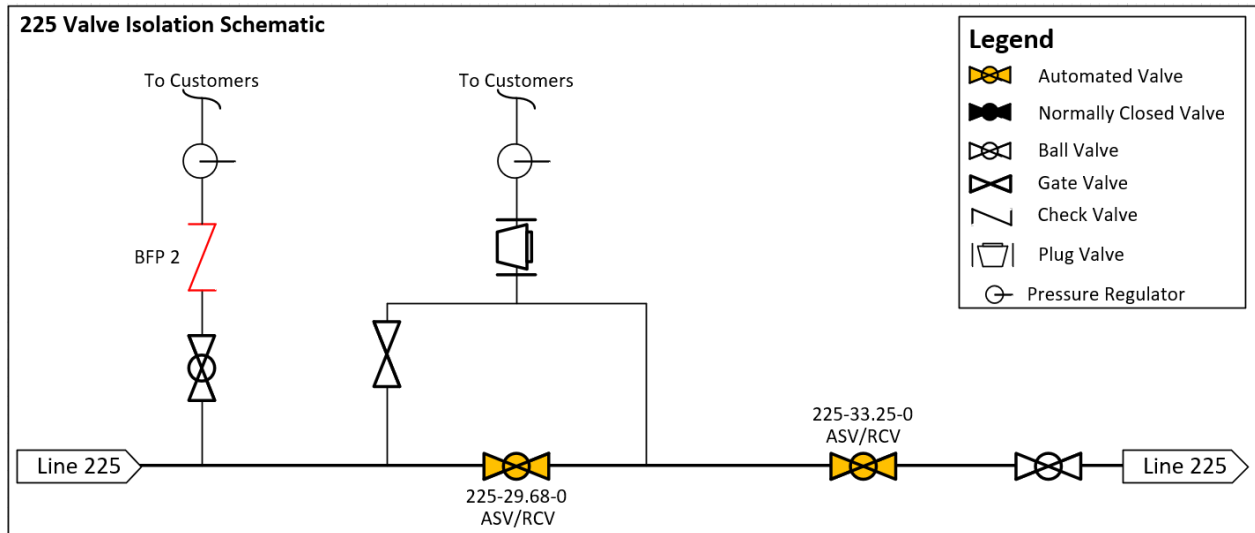

Pipeline Safety Enhancement Plan Final Report
Line 225 Valve Enhancement Project Bundle

D. Scope Changes

SoCalGas and SDG&E did not make any notable scope changes during detailed design.

Pipeline Safety Enhancement Plan Final Report
Line 225 Valve Enhancement Project Bundle

III. CONSTRUCTION

A. Construction Contractor Selection

The Project Team prepared an initial cost estimate based on the preliminary design. Following completion of the engineering, design, and planning activities described above, the Project Team directed the Performance Partner (Mechanical Construction Contractor) and Alliance Partner (Electrical Contractor) to prepare cost estimates based on a more detailed engineering design package. As indicated above, there were no notable changes in scope between the time when the Project Team prepared the preliminary cost estimate and when the Performance Partner and Alliance Partner prepared and submitted their estimates.

1. SoCalGas and SDG&E's Preliminary Mechanical Construction Contractor Estimate (*confidential*): SoCalGas and SDG&E's preliminary cost estimate for construction was [REDACTED].
2. Mechanical Construction Contractor's Target Price Estimate (*confidential*): The Mechanical Construction Contractor's cost estimate was [REDACTED], which was [REDACTED] than SoCalGas and SDG&E's preliminary cost estimate for construction.
3. SoCalGas and SDG&E's Preliminary Electrical Contractor Estimate (*confidential*): SoCalGas and SDG&E's preliminary cost estimate for construction was [REDACTED].
4. Electrical Contractor's Estimate (*confidential*): The Electrical Contractor's estimate was [REDACTED], which was [REDACTED] than SoCalGas and SDG&E's preliminary cost estimate.

Pipeline Safety Enhancement Plan Final Report
Line 225 Valve Enhancement Project Bundle

B. Construction Schedule

Table 3: Construction Timeline

A Street	
Construction Start Date	08/08/2016
Construction Completion Date	08/18/2016
Days on Site	7 days
Commissioning Date	8/18/2016
Laval Road	
Construction Start Date	08/22/2016
Construction Completion Date	09/26/2016
Days on Site	25 days
Commissioning Date	06/15/2017
Edmonson Site	
Construction Start Date	11/14/2016
Construction Completion Date	02/08/2017
Days on Site	49 days
Commissioning Date	06/14/2017

The Project Team completed all construction activities as soon as practicable prior to commissioning. SoCalGas and SDG&E’s finalization of commissioning activities is dependent on electrical utility connections, and system and/or resource availability.

C. Changes During Construction

SoCalGas and SDG&E successfully mitigated conditions during construction in a manner that minimized potential impacts on project scope, cost, and schedule. As a result, these conditions did not result in any notable change orders.

Pipeline Safety Enhancement Plan Final Report
Line 225 Valve Enhancement Project Bundle

Figure 6: A Street – Post Construction



Pipeline Safety Enhancement Plan Final Report
Line 225 Valve Enhancement Project Bundle

Figure 7: Laval Road – Actuator in Foreground, Shelter with Radio Antenna in Background



Pipeline Safety Enhancement Plan Final Report
Line 225 Valve Enhancement Project Bundle

Figure 8: Line 225 Valve Enhancement Project Bundle – Edmonston: Unloading of the New Actuator



Pipeline Safety Enhancement Plan Final Report
Line 225 Valve Enhancement Project Bundle

D. Commissioning and Site Restoration

Commissioning activities included site restoration, final inspections, and placement of the valves into service. During this stage, SoCalGas and SDG&E successfully performed site acceptance testing and conducted point-to-point verification with SoCalGas Gas Control personnel for the newly-automated valves. SoCalGas and SDG&E trained Field Operations personnel on the proper use and operation of the new equipment. Closeout activities included development of final drawings, the reconciliation package, and updates to company recordkeeping systems to reflect the completed scope of work. The sites were commissioned on August 18, 2016, June 14, 2017, and June 15, 2017, as summarized in Table 3.

Pipeline Safety Enhancement Plan Final Report
Line 225 Valve Enhancement Project Bundle

IV. PROJECT COSTS

A. Cost Avoidance Actions

SoCalGas and SDG&E exercised due diligence in the design, planning, and construction activities for this project to minimize or avoid costs when prudent to do so. As discussed above, the Project Team reviewed existing records, communicated with external stakeholders, and conducted a pre-design site walk to incorporate the known site conditions in the project plan and design. Specific examples of cost avoidance actions taken on this project were:

1. Planning and Coordination: The Project Team bundled projects to coordinate engineering and construction activity between the three project sites.
2. Land Use: The Project Team expanded the existing facility at the Edmonston site; however, the Project Team designed the Project so that the new facility limits were within the existing easement avoiding the costs of acquiring additional land.

Pipeline Safety Enhancement Plan Final Report
Line 225 Valve Enhancement Project Bundle

B. Cost Estimates

Based on the preliminary design, once the preliminary project scope was confirmed and engineering, design, and planning activities were underway, SoCalGas and SDG&E prepared an estimate of the Direct Costs of the Project in the amount of \$2,521,988. This estimate was prepared in April of 2016, using the “Stage 3 SCG Valve Estimate Template Rev 3” estimating tool, the most current version of the PSEP Estimate Template at the time. The Project Team considered the conditions known at the time to prepare the preliminary Direct Cost estimate. This estimate reflects the projected Labor, Material and Services costs anticipated to be incurred to execute the Project, based on initial design plans.

SoCalGas and SDG&E estimated Indirect Costs of the Project based on the estimated Direct Costs and other project related variables.

C. Actual Direct and Indirect Costs

Actual Direct Costs reflect the Labor, Material, and Services costs incurred to execute the Project. Actual Indirect Costs reflect costs for incremental overhead loaders in accordance with Company overhead allocation policies. The total loaded cost of the Project is \$2,574,554.

Pipeline Safety Enhancement Plan Final Report
Line 225 Valve Enhancement Project Bundle

Table 4: Estimated and Actual Direct Costs and Variances

Direct Costs (\$)	Estimate	Actuals	Delta Over/(Under)
Company Labor	242,039	115,330	(126,709)
Materials	202,400	164,083	(38,317)
Mechanical Construction Contractor	681,142	580,105	(101,037)
Electrical Contractor	206,370	213,629	7,259
Construction Management & Support	238,723	266,041	27,318
Environmental	92,400	33,174	(59,226)
Engineering & Design	446,212	509,016	62,804
Project Management & Services	123,020	100,177	(22,843)
ROW & Permits	60,409	22,764	(37,645)
GMA	229,273	263,564	34,291
Total Direct Costs	2,521,988	2,267,883	(254,105)

Table 5: Estimated and Actual Indirect Costs, Total Costs, and Variances

Indirect Costs/Total Costs (\$)	Estimate	Actuals	Delta Over/(Under)
Overheads	526,670	201,336	(325,334)
AFUDC	268,599	85,290	(183,309)
Property Taxes	60,472	20,045	(40,427)
Total Indirect Costs	855,741	306,671	(549,070)
Total Direct Costs	2,521,988	2,267,883	(254,105)
Total Loaded Costs	3,377,729	2,574,554	(803,175)

Pipeline Safety Enhancement Plan Final Report
Line 225 Valve Enhancement Project Bundle

V. CONCLUSION

SoCalGas and SDG&E enhanced the safety of their integrated natural gas system by prudently executing the Line 225 Valve Enhancement Project Bundle. Through this Valve Enhancement Project Bundle, SoCalGas and SDG&E successfully automated two MLVs and installed a new check valve to achieve the objective of enabling rapid system isolation near the City of Arvin and community of Lebec. The total loaded cost of the Project is \$2,574,554.

SoCalGas and SDG&E executed this project prudently through designing and executing the Project to support achievement of Valve Enhancement Plan isolation objectives, coordinating and bundling three valve projects into a comprehensive construction package to capture efficiencies through coordinated scheduling of construction crews, and installing equipment necessary to bring power and communication capabilities to two of the sites to enable rapid system isolation to portions of Line 225 and Supply Line 44-623 in Kern County.

SoCalGas and SDG&E engaged in prudent cost avoidance efforts to complete this safety enhancement at a reasonable cost by carefully planning and coordinating construction activity, and by limiting the number of mobilizations across three different project sites to maximize efficiencies and reduce customer and community impacts.

End of Line 225 Valve Enhancement Project Bundle Final Report

Pipeline Safety Enhancement Plan Final Report
Line 235-335 East Valve Enhancement Project Bundle

I. LINE 235-335 EAST VALVE ENHANCEMENT PROJECT BUNDLE

A. Background and Summary

This report describes the activities associated with the Line 235-335 East Valve Enhancement Project Bundle that consists of valve enhancements made to one new mainline valve (MLV), and six existing MLVs in the Cities of Littlerock, Phelan, Palmdale and Llano in Los Angeles and San Bernardino County. Through this project, SoCalGas and SDG&E enhanced the capabilities of seven MLVs to provide rapid transmission system isolation to portions of Lines 235 and 335. SoCalGas and SDG&E installed three new actuators, new communications equipment, and the necessary automation equipment at the sites. The total loaded project cost is \$3,893,642.

The four valves comprising the Line 235-335 East Valve Enhancement Project Bundle are located in desert environments and are separated into six different sites. SoCalGas and SDG&E grouped the six project sites together into a single valve bundle and executed the six sites as a comprehensive package because the sites are geographically proximate and are locations where work could be performed simultaneously, such that the Project Team could manage the work load between project sites and capture efficiencies by limiting the number of mobilizations and demobilizations.

Pipeline Safety Enhancement Plan Final Report
Line 235-335 East Valve Enhancement Project Bundle

Table 1: General Project Information

L235-335 Valve Enhancement Project Bundle			
Site	MLV 18	MLV 19	Littlerock Station
Location	Phelan	Palmdale	Littlerock
Days on Site	18 days	17 days	71 days
Construction Start	02/10/2017	04/17/2017	10/03/2016
Construction Finish	04/05/2017	05/16/2017	01/31/2017
Commissioning Date	01/04/2018	05/23/2018	08/17/2017
Valve Upgrades			
Valve Number	235-181.57-0	235-192.96-0	235-204.63-0
Valve Type	Existing – Ball	Existing – Ball	Existing – Ball
Actuator	New	Existing	Existing
Actuator Above-/Below-Grade	Above-Grade	Above-Grade	Above-Grade
ASV	Yes	Yes	Yes
RCV	No	No	Yes
Valve Number			335-27.13-0
Valve Type			New – Ball
Actuator			New
Actuator Above-/Below-Grade			Above-Grade
ASV			Yes
RCV			Yes
Site Upgrades			
Vault	None	None	None
Power	Existing – Utility	Existing – Solar	Existing – Solar
Communication	New – Radio	New – Radio	New – Radio
SCADA Panel	New	None	None
Equipment Shelter	New	None	None
Fencing	Replaced	Replaced	Replaced
Line 235-335 East Valve Enhancement Project Bundle			
Site	MLV 18A	MLV 19A	MLV 20A
Location	Phelan	Llano	Littlerock
Days on Site	15 days	22 days	19 days
Construction Start	03/14/2017	03/27/2017	02/27/2017
Construction Finish	04/04/2017	05/01/2017	04/10/2017
Commissioning Date	09/12/2017	09/13/2017	09/17/2018

Pipeline Safety Enhancement Plan Final Report
Line 235-335 East Valve Enhancement Project Bundle

Table 1: General Project Information (Continued)

Valve Upgrades			
Valve Number	335-7.84-0	335-20.05-0	335-30.09-0
Valve Type	Existing – Ball	Existing – Ball	Existing – Ball
Actuator	Existing	New	Existing
Actuator Above-/Below-Grade	Above-Grade	Above-Grade	Above-Grade
ASV	Yes	Yes	Yes
RCV	No	No	No
Site Upgrades			
Vault	None	None	None
Power	Existing – Solar	Existing – Solar	Existing – Solar
Communication	New – Radio	New – Radio	New – Radio
SCADA Panel	None	None	None
Equipment Shelter	None	None	None
Fencing	Replaced	Replaced	Replaced
Project Costs (\$)	Capital	O&M	Total
Loaded Project Costs	3,893,642	-	3,893,642
Disallowed Costs	-	-	-

Pipeline Safety Enhancement Plan Final Report
Line 235-335 East Valve Enhancement Project Bundle

B. Maps and Images

Figure 1: Satellite Image of Line 235-335 East Valve Enhancement Project Bundle:
Overview

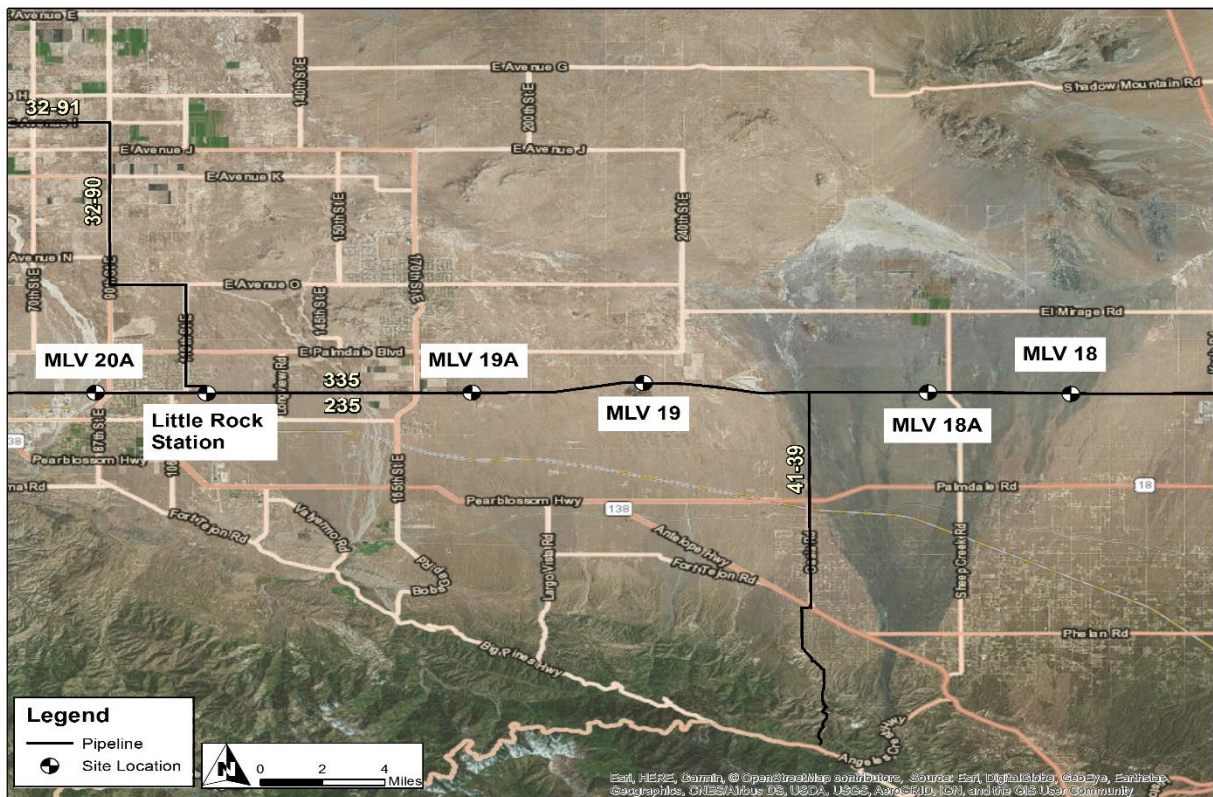

Pipeline Safety Enhancement Plan Final Report
Line 235-335 East Valve Enhancement Project Bundle

Figure 2: Satellite Image of MLV 18

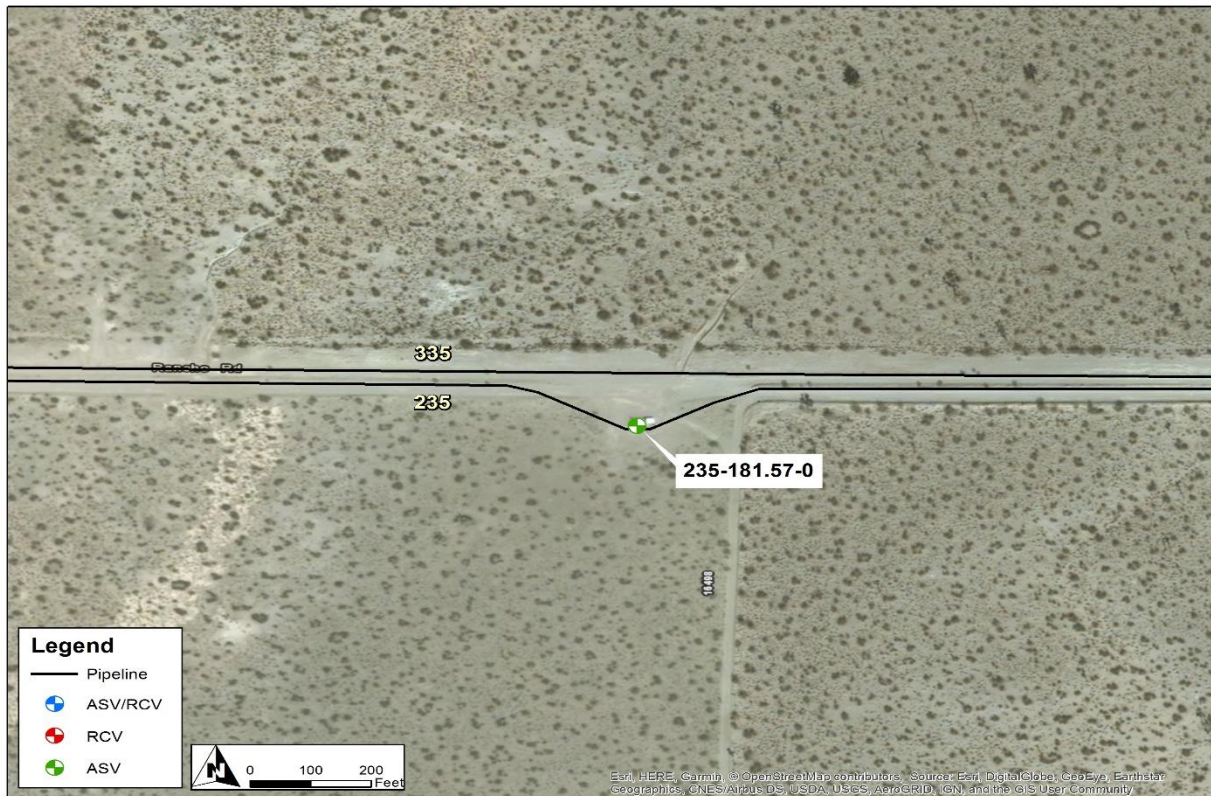

Pipeline Safety Enhancement Plan Final Report
Line 235-335 East Valve Enhancement Project Bundle

Figure 3: Satellite Image of MLV 19



Pipeline Safety Enhancement Plan Final Report
Line 235-335 East Valve Enhancement Project Bundle

Figure 4: Satellite Image of Littlerock Station



Pipeline Safety Enhancement Plan Final Report Line 235-335 East Valve Enhancement Project Bundle

Figure 5: Satellite Image of MLV 18A



Pipeline Safety Enhancement Plan Final Report Line 235-335 East Valve Enhancement Project Bundle

Figure 6: MLV 19A



Pipeline Safety Enhancement Plan Final Report Line 235-335 East Valve Enhancement Project Bundle

Figure 7: MLV 20A



Pipeline Safety Enhancement Plan Final Report
Line 235-335 East Valve Enhancement Project Bundle

II. ENGINEERING, DESIGN, AND PLANNING

A. Project Scope

SoCalGas and SDG&E presented a conceptual project scope in workpapers supporting the Valve Enhancement Plan¹ in the 2011 filing. This conceptual scope identified six valves for automation to provide remote isolation to a portion of Lines 235 and 335. Prior to initiating execution of the Project, SoCalGas and SDG&E reviewed available information and performed a detailed system flow analysis to validate the scope of the Project. This resulted in the identification of three additional valves for enhancement to provide the planned isolation. The final project scope is summarized in Table 2 below.

1. 2011 PSEP Filing: SoCalGas and SDG&E identified MLVs 235-181.57-0, 235-204.63-0, 235-215.22-0, 335-7.84-0, 335-30.09-0, and 335-37.73-0, for automation to achieve the objective of rapid system isolation.

¹ See Workpapers supporting Amended Pipeline Safety Enhancement Plan (PSEP) of SoCalGas and SDG&E, submitted on December 2, 2011, at WP-IX-2-14 through WP-IX-2-25 (A.11-11-002 Exh. # SCG-32).

Pipeline Safety Enhancement Plan Final Report
Line 235-335 East Valve Enhancement Project Bundle

2. Updated Scope: Upon project initiation, SoCalGas and SDG&E reviewed the conceptual project scope and determined that automation of these alone would not achieve the transmission isolation objectives set forth in the Valve Enhancement Plan. SoCalGas and SD&E determined it was also necessary to automate two additional existing valves, one on Line 235 and one on Line 335, and one new valve on Line 335. Additionally, valves 235-215.22-0 and 335-37.73-0, were removed from this bundle and were completed as a separate PSEP valve project, which was included for review in the 2016 PSEP Reasonableness Review Application (A.16-09-005). Together, the automation of the seven valves enables rapid isolation, achieving Valve Enhancement Plan objectives.
3. Engineering, Design, and Constructability:
 - a. SoCalGas and SDG&E determined that a new MLV was required on a section of Line 335 due to a change in Class Location. SoCalGas and SDG&E selected this valve for automation to meet the PSEP isolation criteria. The Operating District funded the cost of installing the new MLV.
 - b. SoCalGas and SDG&E identified existing MLVs 235-192.96-0 and 335-20.05-0 for automation to meet PSEP spacing criteria.
4. Final Project Scope: The final project scope consists of the automation of one new valve and six existing valves, that included the installation of one new MLV, three new actuators, new communications equipment and the installation of the necessary automation equipment at the project sites.

Pipeline Safety Enhancement Plan Final Report
Line 235-335 East Valve Enhancement Project Bundle

Table 2: Final Project Scope

Final Project Scope					
Line	Mile	Valve #	Valve Size (confidential)	Installation Type	Function
235	181.57	0	████████	COMM	ASV
235	192.96	0	████████	COMM	ASV
235	204.63	0	████████	C/P	ASV/RCV
335	7.84	0	████████	COMM	ASV
335	27.13	0	████████	A/AG	ASV/RCV
335	20.05	0	████████	COMM	ASV
335	30.09	0	████████	COMM	ASV

B. Site Evaluation and Planning

SoCalGas and SDG&E initiated the planning process for the Line 235-335 East Valve Enhancement Project Bundle by performing a pre-design site walk to determine the existing conditions and assess any potential impacts on the design. Key factors that influenced the engineering and design of this project are as follows:

MLV 18

1. Site Description: This site is an existing SoCalGas facility located in a desert environment.
2. Land Issues: During the pre-design site walk, the Project Team noted that the existing facility can accommodate the new equipment.
3. DOT Class: This project site is in a Class 1 location. SoCalGas and SDG&E selected this MLV for automation to isolate an HCA location upstream of this valve.
4. Power Source: The site has existing solar power.

Pipeline Safety Enhancement Plan Final Report
Line 235-335 East Valve Enhancement Project Bundle

5. Communication Technology: There was no preexisting communications equipment, the Project Team installed new communications equipment at the site.

MLV 19

1. Site Description: This site is an existing SoCalGas facility in a desert environment.
2. Land Issues: During the pre-design site walk, the Project Team noted that the existing facility can accommodate the new equipment.
3. DOT Class: This project site is located in a Class 1 location. SoCalGas and SDG&E selected this MLV for automation in accordance with the Valve Enhancement Plan as there was existing power and Lineguard technology.
4. Power Source: The site has existing solar power.
5. Communication Technology: There was no preexisting communications equipment, the Project Team installed new communications equipment at the site.

Littlerock Station

1. Site Description: This site is an existing, fenced in SoCalGas facility. Line 335 is located in the street and was rerouted into the facility where the new MLV was installed. There is a feed to an existing SoCalGas regulator station.
2. Land Issues: During the pre-design site walk, the Project Team noted that excavations will impact the street.
3. DOT Class: This project site is in a Class 1 location.
 - a. 235-204.63-0: SoCalGas and SDG&E selected this MLV for automation to isolate an HCA location upstream of this valve.

Pipeline Safety Enhancement Plan Final Report
Line 235-335 East Valve Enhancement Project Bundle

- b. 335-27.13-0: SoCalGas and SDG&E selected this MLV for automation to isolate an HCA location upstream of this valve and to satisfy the PSEP spacing criteria.
4. Power Source: The site has existing utility power.
5. Communication Technology: There was no preexisting communications equipment, the Project Team installed new communications equipment at the site.

MLV 18A

1. Site Description: This site is an existing SoCalGas facility in a desert environment.
2. Land Issues: During the pre-design site walk, the Project Team noted that the existing facility can accommodate the new equipment.
3. DOT Class: This project site is located in a Class 1 location. SoCalGas and SDG&E selected this MLV for automation in accordance with the Valve Enhancement Plan as there was existing power and Lineguard technology.
4. Power Source: The site has existing solar power.
5. Communication Technology: There was no preexisting communications equipment, the Project Team installed new communications equipment at the site.

MLV 19A

1. Site Description: This site is an existing SoCalGas facility in a desert environment.
2. Land Issues: During the pre-design site walk, the Project Team noted that the existing facility can accommodate the new equipment.
3. DOT Class: This project site is in a Class 1 location. SoCalGas and SDG&E selected this MLV for automation to isolate an HCA location upstream of this valve.

Pipeline Safety Enhancement Plan Final Report
Line 235-335 East Valve Enhancement Project Bundle

4. Power Source: The site has existing solar power.
5. Communication Technology: There was no preexisting communications equipment, the Project Team installed new communications equipment at the site.

MLV 20A

1. Site Description: This site is an existing SoCalGas facility in a desert environment.
2. Land Issues: During the pre-design site walk, the Project Team noted that the existing facility can accommodate the new equipment.
3. DOT Class: This project site is located in a Class 1 location. SoCalGas and SDG&E selected this MLV for automation to isolate HCA locations upstream and downstream of this valve.
4. Power Source: The site has existing solar power.
5. Communication Technology: There was no preexisting communications equipment, the Project Team installed new communications equipment at the site.

C. Engineering, Design, and Planning Factors

SoCalGas and SDG&E reviewed drawings and records, contacted internal planning groups, communicated with external stakeholders, and completed a pre-design site walk. Key factors that influenced the engineering and design of the Project are as follows:

Pipeline Safety Enhancement Plan Final Report
Line 235-335 East Valve Enhancement Project Bundle

MLV 18

1. Engineering Assessment: During the site evaluation, the Project Team confirmed the preexisting technology and verified that the station could accommodate the new equipment.
2. Valve Details: The existing valve was a manually actuated Class 600 ball valve that the Project Team reused.
3. Actuator Details: The preexisting actuator was incompatible with PSEP linebreak technology, the Project Team installed a new actuator.
4. Customer Impact: The Project Team did not anticipate service disruptions to customers.
5. Community Impact: The Project Team did not anticipate any notable impacts to the community from this Project.
6. Substructures: The Project Team did not identify any existing substructures that affected the design and engineering at this site.
7. Environmental: The Project Team completed a biological survey prior to construction activities and gave the construction contractors approval to proceed. An environmental monitor performed spot checks during construction.
8. Permit Restrictions: There were no special permits or permit restrictions for this project site.
9. Land Use: The Project Team performed all work within the existing SoCalGas facility.

Pipeline Safety Enhancement Plan Final Report
Line 235-335 East Valve Enhancement Project Bundle

10. Traffic Control: The Project Team did not identify any traffic control needs at the site.

MLV 19

1. Engineering Assessment: During the site evaluation, the Project Team confirmed the preexisting technology and verified that the station could accommodate the new equipment.
2. Valve Details: The existing valve was a manually actuated Class 600 ball valve that the Project Team reused.
3. Actuator Details: The existing actuator was a double-acting pneumatic actuator that the Project Team reused.
4. Customer Impact: The Project Team did not anticipate service disruptions to customers.
5. Community Impact: The Project Team did not anticipate any notable impacts to the community from this Project.
6. Substructures: The Project Team did not identify any existing substructures that affected the design and engineering at this site.
7. Environmental: The Project Team completed a biological survey prior to construction activities and gave the construction contractors approval to proceed. An environmental monitor performed spot checks during construction.
8. Permit Restrictions: There were no special permits or permit restrictions for this project site.

Pipeline Safety Enhancement Plan Final Report
Line 235-335 East Valve Enhancement Project Bundle

9. Land Use: The Project Team performed all work within the existing SoCalGas facility.
10. Traffic Control: The Project Team did not identify any traffic control needs at the site.

Little Rock Station

1. Engineering Assessment: During the site evaluation, the Project Team confirmed the preexisting technology and verified that the station could accommodate the new equipment. The Project Team determined that Line 335 needed to be relocated into the existing facility.
2. Valve Details:
 - a. 235-204.63-0: The existing valve was a manually actuated Class 600 ball valve that the Project Team reused.
 - b. 335-27.13-0: There was no existing valve, the Operating District installed a new, Class 600 ball valve.
3. Actuator Details:
 - a. 235-204.63-0: The existing actuator was a double-acting pneumatic actuator that the Project Team reused.
 - b. 335-27.13-0: There was no preexisting actuator, the Project Team installed a new actuator.
4. Customer Impact: The Project Team did not anticipate service disruptions to customers. The Project Team utilized a pressure control fitting to stop the feed to Supply Line 44-651.

Pipeline Safety Enhancement Plan Final Report
Line 235-335 East Valve Enhancement Project Bundle

5. Community Impact: The Project Team did not anticipate any notable impacts to the community from this Project.
6. Substructures: The Project Team did not identify any existing substructures that affected the design and engineering at this site.
7. Environmental: The Project Team completed a biological survey prior to construction activities and identified burrows belonging to the Mojave Ground Squirrel. The Project Team marked the active burrows and installed temporary fencing to prevent any of the squirrels from entering the work area. An environmental monitor performed spot checks during construction.
8. Permit Restrictions: There were no special permit restrictions for this project site.
9. Land Use: The Project Team utilized existing easements for a laydown yard and to perform construction activities.
10. Traffic Control: One lane of traffic was closed for a portion of construction. The road is lightly traveled. The Mechanical Construction Contractor rerouted traffic as necessary.

MLV 18A

1. Engineering Assessment: During the site evaluation, the Project Team confirmed the preexisting technology and verified that the station could accommodate the new equipment.
2. Valve Details: The existing valve was a manually actuated Class 600 ball valve that the Project Team reused.

Pipeline Safety Enhancement Plan Final Report
Line 235-335 East Valve Enhancement Project Bundle

3. Actuator Details: The existing actuator was a double-acting pneumatic actuator that the Project Team reused.
4. Customer Impact: The Project Team did not anticipate service disruptions to customers.
5. Community Impact: The Project Team did not anticipate any impacts to the community from this Project.
6. Substructures: The Project Team did not identify any existing substructures that affected the design and engineering at this site.
7. Environmental: The Project Team completed a biological survey prior to construction activities and gave the construction contractors approval to proceed. An environmental monitor performed spot checks during construction.
8. Permit Restrictions: There were no special permits or permit restrictions for this project site.
9. Land Use: The Project Team performed all work within the existing SoCalGas facility.
10. Traffic Control: The Project Team did not identify any traffic control needs at the site.

Site 5: MLV 19A

1. Engineering Assessment: During the site evaluation, the Project Team confirmed the preexisting technology and verified that the station could accommodate the new equipment.

Pipeline Safety Enhancement Plan Final Report
Line 235-335 East Valve Enhancement Project Bundle

2. Valve Details: The existing valve was a manually actuated Class 600 ball valve that the Project Team reused.
3. Actuator Details: The preexisting actuator was incompatible with PSEP linebreak technology, the Project Team installed a new actuator.
4. Customer Impact: The Project Team did not anticipate service disruptions to customers.
5. Community Impact: The Project Team did not anticipate any impacts to the community from this Project.
6. Substructures: The Project Team did not identify any existing substructures that affected the design and engineering at this site.
7. Environmental: The Project Team completed a biological survey prior to construction activities and gave the construction contractors approval to proceed. An environmental monitor performed spot checks during construction.
8. Permit Restrictions: There were no special permits or permit restrictions for this project site.
9. Land Use: The Project Team performed all work within the existing SoCalGas facility.
10. Traffic Control: The Project Team did not identify any traffic control needs at the site.

Pipeline Safety Enhancement Plan Final Report
Line 235-335 East Valve Enhancement Project Bundle

Site 6: MLV 20A

1. Engineering Assessment: During the site evaluation, the Project Team confirmed the preexisting technology and verified that the station could accommodate the new equipment.
2. Valve Details: The existing valve was a manually actuated Class 600 ball valve that the Project Team reused.
3. Actuator Details: The existing actuator was a double-acting pneumatic actuator that the Project Team reused.
4. Customer Impact: The Project Team did not anticipate service disruptions to customers.
5. Community Impact: The Project Team did not anticipate any impacts to the community from this Project.
6. Substructures: The Project Team did not identify any existing substructures that affected the design and engineering at this site.
7. Environmental: The Project Team completed a biological survey prior to construction activities and gave the construction contractors approval to proceed. An environmental monitor performed spot checks during construction.

Pipeline Safety Enhancement Plan Final Report
Line 235-335 East Valve Enhancement Project Bundle

8. Permit Restrictions: There were no special permits or permit restrictions for this project site.
9. Land Use: The Project Team performed all work within the existing SoCalGas facility.
10. Traffic Control: The Project Team did not identify any traffic control needs at the site

Pipeline Safety Enhancement Plan Final Report Line 235-335 East Valve Enhancement Project Bundle

Figure 8: Line 235-335 East Valve Enhancement Project Bundle Schematic

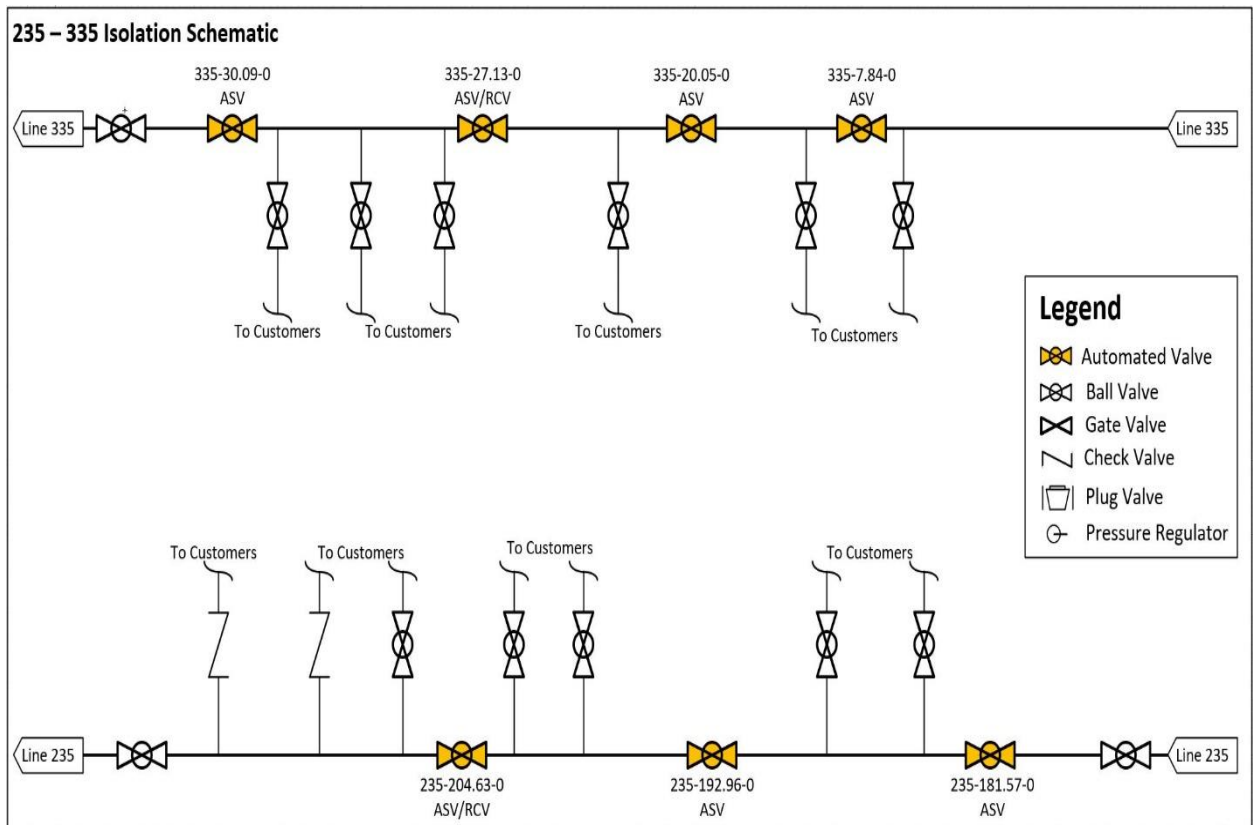

Pipeline Safety Enhancement Plan Final Report
Line 235-335 East Valve Enhancement Project Bundle

D. Scope Changes

SoCalGas and SDG&E did not make any notable scope changes during detailed design.

Pipeline Safety Enhancement Plan Final Report
Line 235-335 East Valve Enhancement Project Bundle

III. CONSTRUCTION

A. Construction Contractor Selection

The Project Team prepared an initial cost estimate based on the preliminary design. Following completion of the engineering, design, and planning activities described above, the Project Team directed the Performance Partner (Mechanical Construction Contractor) and Alliance Partner (Electrical Contractor) to prepare cost estimates based on a more detailed engineering design package. As indicated above, there were no notable changes in scope between the time when the Project Team prepared the preliminary cost estimate and when the Performance Partner and Alliance Partner prepared and submitted their estimates. The estimated values below include PSEP and non-PSEP work, whereas Table 4 and 5 include estimated and actual values for PSEP work only.

1. SoCalGas and SDG&E's Preliminary Mechanical Construction Contractor Estimate (*confidential*): SoCalGas and SDG&E's preliminary cost estimate for construction was [REDACTED].
2. Mechanical Construction Contractor's Target Price Estimate (*confidential*): The Mechanical Construction Contractor's cost estimate for the entire project was [REDACTED] which was [REDACTED] than SoCalGas and SDG&E's preliminary cost estimate for construction.
3. SoCalGas and SDG&E's Preliminary Electrical Contractor Estimate (*confidential*): SoCalGas and SDG&E's preliminary cost estimate for construction was [REDACTED].

Pipeline Safety Enhancement Plan Final Report
Line 235-335 East Valve Enhancement Project Bundle

4. Electrical Contractor's Estimate (*confidential*): The Electrical Contractor's estimate was [REDACTED], which was [REDACTED] than SoCalGas and SDG&E's preliminary cost estimate.

Pipeline Safety Enhancement Plan Final Report
Line 235-335 East Valve Enhancement Project Bundle

B. Construction Schedule

Table 3: Construction Timeline

MLV 18	
Construction Start Date	02/10/2017
Construction Completion Date	04/05/2017
Days on Site	18 days
Commissioning Date	01/04/2018
MLV 19	
Construction Start Date	04/17/2017
Construction Completion Date	05/16/2017
Days on Site	17 days
Commissioning Date	05/23/2018
Littlerock Station	
Construction Start Date	10/03/2016
Construction Completion Date	01/31/2017
Days on Site	71 days
Commissioning Date	08/17/2017
MLV 18A	
Construction Start Date	03/14/2017
Construction Completion Date	04/04/2017
Days on Site	15 days
Commissioning Date	09/12/2017
MLV 19A	
Construction Start Date	03/27/2017
Construction Completion Date	05/01/2017
Days on Site	22 days
Commissioning Date	09/13/2017
MLV 20A	
Construction Start Date	02/27/2017
Construction Completion Date	04/10/2017
Days on Site	19 days
Commissioning Date	09/17/2018

Pipeline Safety Enhancement Plan Final Report
Line 235-335 East Valve Enhancement Project Bundle

The Project Team completed all construction activities as soon as practicable prior to commissioning. SoCalGas and SDG&E's finalization of commissioning activities is dependent on electrical utility connections, and system and/or resource availability.

C. Changes During Construction

SoCalGas and SDG&E successfully mitigated conditions during construction in a manner that minimized potential impacts on project scope, cost, and schedule. As a result, construction conditions did not result in any notable change orders applied to PSEP.

Pipeline Safety Enhancement Plan Final Report
Line 235-335 East Valve Enhancement Project Bundle

Figure 9: MLV 19 – Existing Cabinet and Solar Array in Foreground, Existing Actuator in Background



Pipeline Safety Enhancement Plan Final Report
Line 235-335 East Valve Enhancement Project Bundle

Figure 10: Completed Littlerock Station



Pipeline Safety Enhancement Plan Final Report
Line 235-335 East Valve Enhancement Project Bundle

Figure 11: MLV 19A – New Fencing and Existing Blowdown



Pipeline Safety Enhancement Plan Final Report
Line 235-335 East Valve Enhancement Project Bundle

D. Commissioning and Site Restoration

Commissioning activities included site restoration, final inspections, and placement of the valves into service. During this stage, SoCalGas and SDG&E successfully performed site acceptance testing and conducted point-to-point verification with SoCalGas Gas Control personnel for the newly-automated valves. SoCalGas and SDG&E trained Field Operations personnel on the proper use and operation of the new equipment. Closeout activities included development of final drawings, the reconciliation package, and updates to company recordkeeping systems to reflect the completed scope of work. The sites were commissioned on August 17, 2017, September 12, 2017, September 13, 2017, January 4, 2018, May 23, 2018 and September 17, 2018, as summarized in Table 3.

Pipeline Safety Enhancement Plan Final Report
Line 235-335 East Valve Enhancement Project Bundle

IV. PROJECT COSTS

A. Cost Avoidance Actions

SoCalGas and SDG&E exercised due diligence in the design, planning, and construction activities for this project to minimize or avoid costs when prudent to do so. As discussed above, the Project Team reviewed existing records, communicated with external stakeholders, and conducted a site walk to incorporate the known site conditions in the project plan and design. Specific examples of cost avoidance actions taken on this project were:

1. Planning and Coordination:
 - a. The Project Team bundled projects to coordinate engineering and construction activity between the six project sites.
 - b. SoCalGas and SDG&E coordinated the installation of the new MLV at the Littlerock Station with the PSEP automation work.

B. Cost Estimates

Based on the preliminary design, once the preliminary project scope was confirmed and engineering, design, and planning activities were underway, SoCalGas and SDG&E prepared an estimate of the Direct Costs of the Project in the amount of \$2,532,578. This estimate was prepared in August of 2016, using the “Stage 3 SCG Valve Estimate Template Rev 3” estimating tool, the most current version of the PSEP Estimate Template at the time. The Project Team considered the conditions known at the time to prepare the preliminary Direct Cost estimate. This estimate reflects the projected Labor, Material and Services costs anticipated to be incurred to execute the Project, based on initial design plans.

Pipeline Safety Enhancement Plan Final Report
Line 235-335 East Valve Enhancement Project Bundle

SoCalGas and SDGE estimated Indirect Costs of the Project based on the estimated Direct Costs and other project-related variables.

C. Actual Direct and Indirect Costs

Actual Direct Costs reflect the Labor, Material, and Services costs incurred to execute the Project. Actual Indirect Costs reflect costs for incremental overhead loaders in accordance with Company overhead allocation policies. The total loaded cost of the Project is \$3,893,642.

Table 4: Estimated and Actual Direct Costs and Variances²

Direct Costs (\$)	Estimate	Actuals	Delta Over/(Under)
Company Labor	196,374	357,939	161,565
Materials	367,715	234,147	(133,568)
Mechanical Construction Contractor	295,443	557,598	262,155
Electrical Contractor	792,491	491,589	(300,902)
Construction Management & Support	154,787	304,521	149,734
Environmental	86,485	189,340	102,855
Engineering & Design	88,208	610,614	522,406
Project Management & Services	71,128	118,931	47,803
ROW & Permits	20,974	44,066	23,092
GMA	458,973	373,984	(84,988)
Total Direct Costs	2,532,578	3,282,729	750,151

² Estimated and Actual costs only reflect PSEP costs.

Pipeline Safety Enhancement Plan Final Report
Line 235-335 East Valve Enhancement Project Bundle

Table 5: Estimated and Actual Indirect Costs, Total Costs, and Variances

Indirect Costs/Total Costs (\$)	Estimate	Actuals	Delta Over/(Under)
Overheads	548,707	469,899	(78,808)
AFUDC	295,466	135,446	(160,020)
Property Taxes	70,140	5,568	(64,572)
Total Indirect Costs	914,313	610,913	(303,400)
Total Direct Costs	2,532,578	3,282,729	750,151
Total Loaded Costs	3,446,891	3,893,641	446,750

Pipeline Safety Enhancement Plan Final Report
Line 235-335 East Valve Enhancement Project Bundle

V. CONCLUSION

SoCalGas and SDG&E enhanced the safety of their integrated natural gas system by prudently executing the Line 235-335 East Valve Enhancement Project Bundle. Through this Valve Enhancement Project Bundle, SoCalGas and SDG&E successfully automated seven MLVs to achieve the objective of enabling rapid system isolation in the Cities of Littlerock, Phelan, Palmdale and Llano. The total loaded cost of the Project is \$3,893,642.

SoCalGas and SDG&E executed this project prudently through designing and executing the Project to support achievement of Valve Enhancement Plan isolation objectives, coordinating work with the Operating District, maintaining service to customers by utilizing a pressure control fitting and installing the equipment necessary to bring communication capabilities to these valves to enable rapid system isolation to portions of Lines 235 and 335.

SoCalGas and SDG&E engaged in prudent cost avoidance efforts to complete this safety enhancement at a reasonable cost by engaging in reasonable efforts to promote competitive and market-based rates for contractor services and materials, and using a reasonable amount of company and contractor resources given the conditions and work scope changes experienced during construction, so as to complete the safety enhancement work as soon as practicable.

End of Line 235-335 East Valve Enhancement Project Bundle Final Report

Pipeline Safety Enhancement Plan Final Report
Line 3010 Valve Enhancement Project Bundle

I. LINE 3010 VALVE ENHANCEMENT PROJECT BUNDLE

A. Background and Summary

This report describes the activities associated with the Line 3010 Valve Enhancement Project Bundle that consists of valve enhancements made to nine existing mainline valves (MLVs) throughout San Diego County. Through this project, SoCalGas and SDG&E enhanced the capabilities of nine MLVs to provide rapid transmission system isolation to a portion of Line 3010. SoCalGas and SDG&E upgraded the existing automation equipment to be compatible with PSEP linebreak technology. SoCalGas and SDG&E installed new solenoid valves, new pressure transducers, new solenoid valves. The total loaded project cost is \$275,538.

Pipeline Safety Enhancement Plan Final Report
Line 3010 Valve Enhancement Project Bundle

Table 1: General Project Information

Line 3010 Valve Enhancement Project Bundle			
	All Sites		
Location	Various		
Days on Site	2-3 days (typical)		
Construction Start	12/22/2014		
Construction Finish	07/27/2015		
Commissioning Date	N/A		
Valve Upgrades			
Valve Number	3003 through 3011		
Valve Type	Existing		
Actuator	Existing		
Actuator Above-/Below-Grade	Above-Grade		
ASV	Yes		
RCV	Yes		
Site Upgrades			
Vault	Existing		
Power	Existing		
Communication	Existing – Radio		
SCADA Panel	Existing		
Equipment Shelter	Existing		
Fencing/Wall	Existing		
Project Costs (\$)	Capital	O&M	Total
Loaded Project Costs	275,538	-	275,538
Disallowed Costs	-	-	-

Pipeline Safety Enhancement Plan Final Report
Line 3010 Valve Enhancement Project Bundle

B. Maps and Images

Figure 1: Satellite Image of Line 3010 Valve Enhancement Project Bundle: Overview

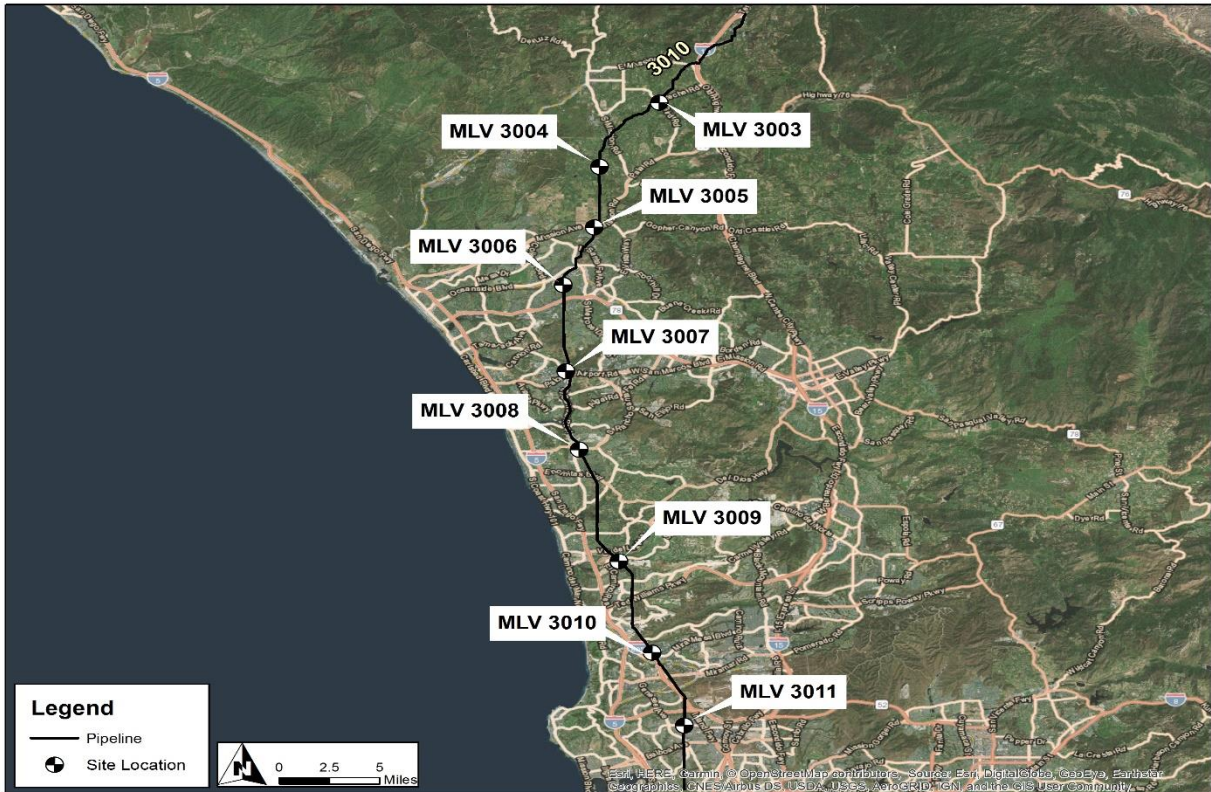

Pipeline Safety Enhancement Plan Final Report Line 3010 Valve Enhancement Project Bundle

Figure 2: Satellite Image of Valve 3010-3003



Pipeline Safety Enhancement Plan Final Report Line 3010 Valve Enhancement Project Bundle

Figure 3: Satellite Image of Valve 3010-3004



Pipeline Safety Enhancement Plan Final Report
Line 3010 Valve Enhancement Project Bundle

Figure 4: Satellite Image of Valve 3010-3005



Pipeline Safety Enhancement Plan Final Report Line 3010 Valve Enhancement Project Bundle

Figure 5: Satellite Image of Valve 3010-3006



Pipeline Safety Enhancement Plan Final Report Line 3010 Valve Enhancement Project Bundle

Figure 6: Satellite Image of Valve 3010-3007



Pipeline Safety Enhancement Plan Final Report Line 3010 Valve Enhancement Project Bundle

Figure 7: Satellite Image of Valve 3010-3008

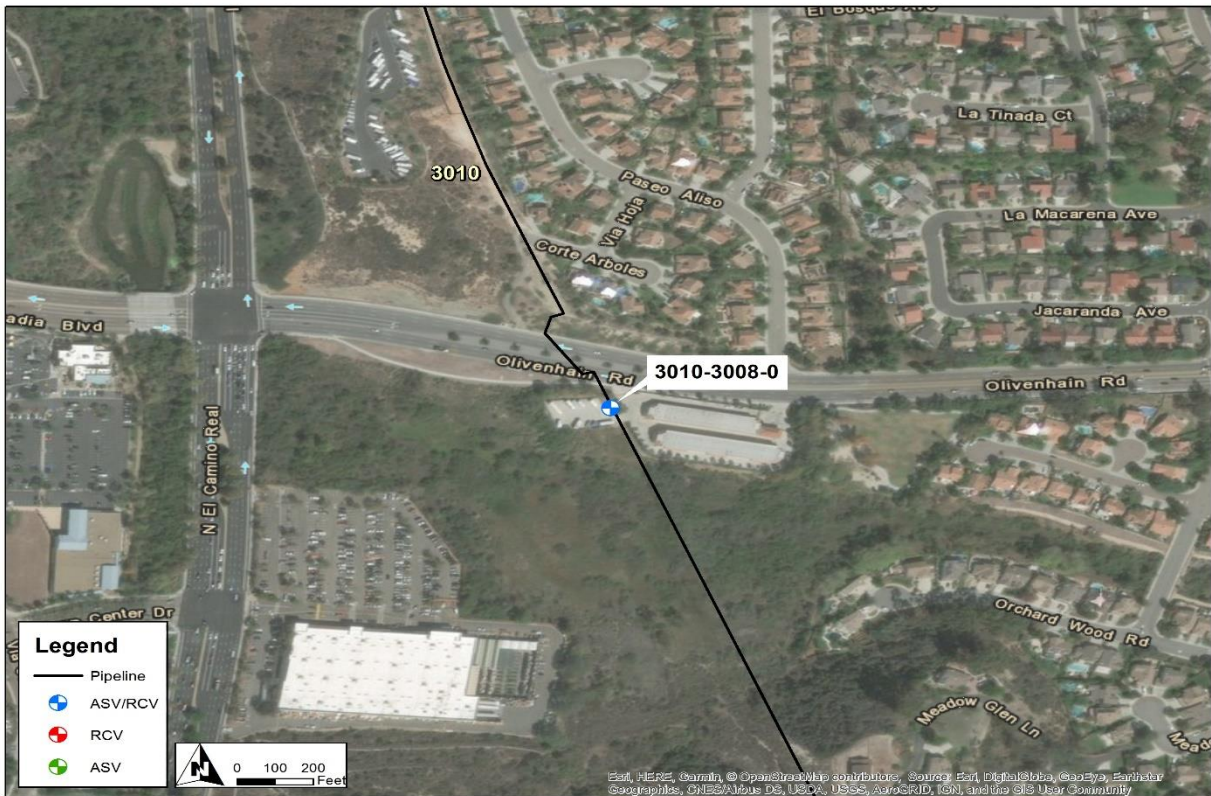

Pipeline Safety Enhancement Plan Final Report Line 3010 Valve Enhancement Project Bundle

Figure 8: Satellite Image of Valve 3010-3009



Pipeline Safety Enhancement Plan Final Report
Line 3010 Valve Enhancement Project Bundle

Figure 9: Satellite Image of Valve 3010-3010

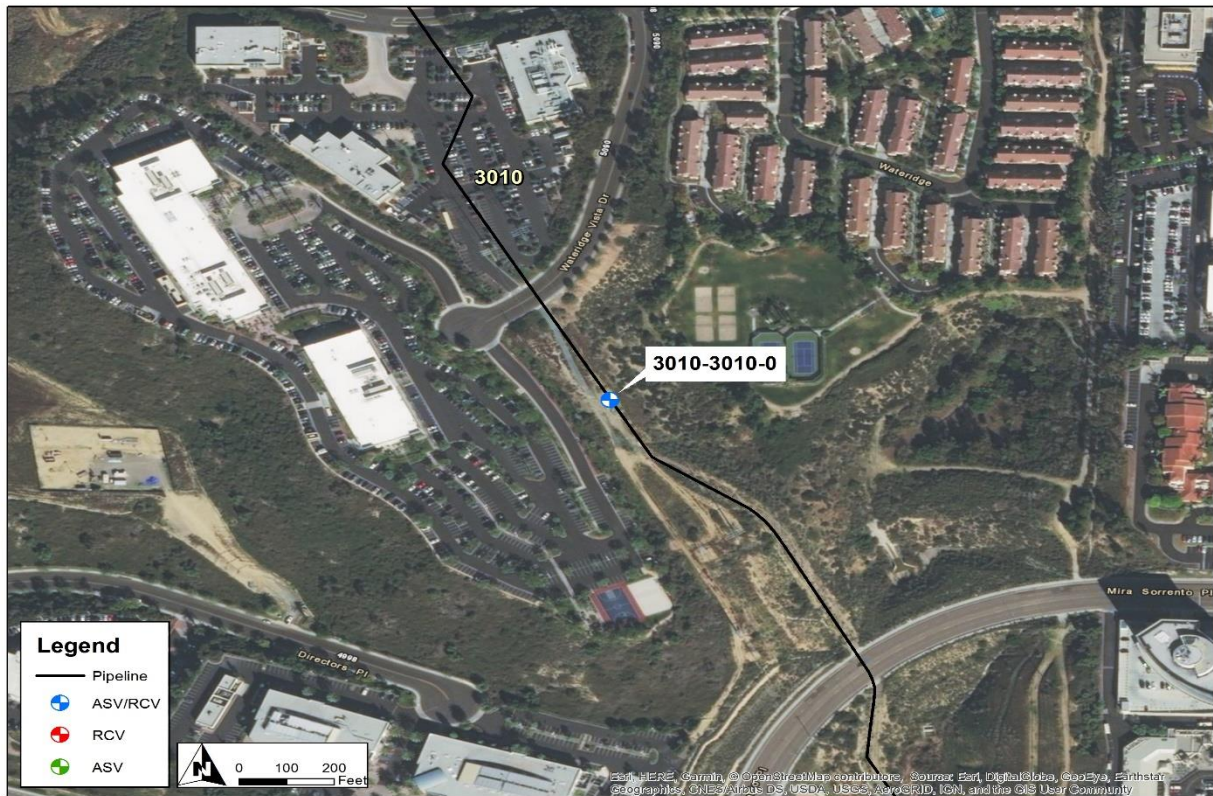

Pipeline Safety Enhancement Plan Final Report Line 3010 Valve Enhancement Project Bundle

Figure 10: Satellite Image of Valve 3010-3011

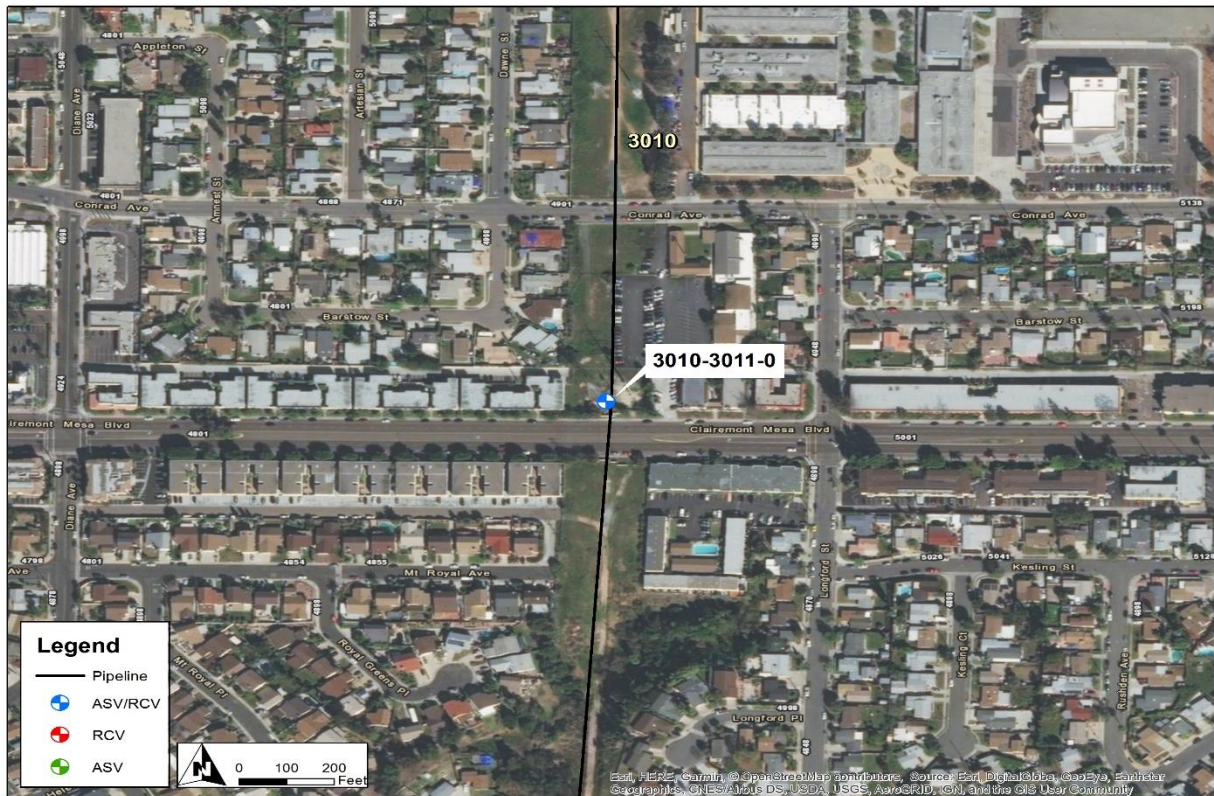

Pipeline Safety Enhancement Plan Final Report
Line 3010 Valve Enhancement Project Bundle

II. ENGINEERING, DESIGN, AND PLANNING

A. Project Scope

SoCalGas and SDG&E presented a conceptual project scope in workpapers supporting the Valve Enhancement Plan¹ in the 2011 filing. This conceptual scope did not include this project. SoCalGas and SDG&E reviewed available information and performed a detailed system flow analysis that identified these valves as candidates for enhancement to provide the planned isolation. The final project scope is summarized in Table 2 below.

1. 2011 PSEP Filing: SoCalGas and SDG&E did not identify these valves for automation to achieve the objective of rapid system isolation.
2. Updated Scope: SoCalGas and SDG&E identified nine valves for automation, as well as the installation of two flow meters. Together, the automation of these 16 valves and the installation of these two flow meters enable rapid isolation, achieving the Valve Enhancement Plan objectives.
3. Engineering, Design, and Constructability: The Project Team evaluated the existing valve automation equipment and determined that the installation of new solenoid valves, new pressure transducers, and new pressure transmitters was all that was necessary to upgrade the existing automation equipment to conform with PSEP design standards.

¹ See Workpapers supporting Amended Pipeline Safety Enhancement Plan (PSEP) of SoCalGas and SDG&E, submitted on December 2, 2011, at WP-IX-2-14 through WP-IX-2-25 (A.11-11-002 Exh. # SCG-32).

Pipeline Safety Enhancement Plan Final Report
Line 3010 Valve Enhancement Project Bundle

4. **Final Project Scope:** The final project scope consists upgrades made to existing automation equipment for nine valves that included the installation of solenoid valves, pressure transducers, and pressure transmitters in the existing automation equipment.

Table 2: Final Project Scope

Final Project Scope					
Line	Mile ²	Valve #	Valve Size (<i>confidential</i>)	Installation Type	Function
3010		3003	████████	COMM	ASV/RCV
3010		3004	████████	COMM	ASV/RCV
3010		3005	████████	COMM	ASV/RCV
3010		3006	████████	COMM	ASV/RCV
3010		3007	████████	COMM	ASV/RCV
3010		3008	████████	COMM	ASV/RCV
3010		3009	████████	COMM	ASV/RCV
3010		3010	████████	COMM	ASV/RCV
3010		3011	████████	COMM	ASV/RCV

B. Site Evaluation and Planning

Key factors that influenced the engineering and design of this project are as follows:

All Sites:

1. **Site Description:** The Project Sites were in urban and rural areas in San Diego County.
2. **Land Issues:** The Project Team determined that all construction activities could be completed within existing easements.

² Valve naming convention at SDG&E does not include milepoint.

Pipeline Safety Enhancement Plan Final Report
Line 3010 Valve Enhancement Project Bundle

3. DOT Class: The Project sites are within Class 3 locations.
4. Power Source: The sites had power equipment.
5. Communication Technology: The site has existing communications.

C. Engineering, Design, and Planning Factors

SoCalGas and SDG&E reviewed drawings and records, and contacted internal planning groups. Key factors that influenced the engineering and design of the Project are as follows:

All Sites:

1. Engineering Assessment: The Project Team confirmed the preexisting technology and verified that the existing automation equipment did not meet the PSEP Valve Enhancement standard. The Project Team determined that the installation of new solenoid valves, new pressure transducers and new pressure transmitters would monitor real-time flow measurements and result in the existing automation equipment meeting the PSEP Valve Enhancement Standard.
2. Valve Details: The existing valves were actuated ball valves that the Project Team reused.
3. Actuator Details: All valves had existing actuators that the Project Team reused.
4. Customer Impact: The Project Team did not anticipate service disruptions to customers.
5. Community Impact: The Project Team did not anticipate any notable impact to the community from this project.

Pipeline Safety Enhancement Plan Final Report
Line 3010 Valve Enhancement Project Bundle

6. Substructures: The Project Team did not identify any existing substructures that affected the design and engineering at this site.
7. Environmental: The Project Team did not identify any notable environmental concerns at the site. An environmental monitor performed spot checks during construction.
8. Permit Restrictions: There were no special permits or permit restrictions for this project site.
9. Land Use: The Project Team performed all work within the existing SDG&E easements.
10. Traffic Control: The Project Team did not identify any traffic control needs at the site

Pipeline Safety Enhancement Plan Final Report Line 3010 Valve Enhancement Project Bundle

Figure 11: Line 3010 Valve Enhancement Project Bundle Schematic:
3010-3003 to 3010-3006

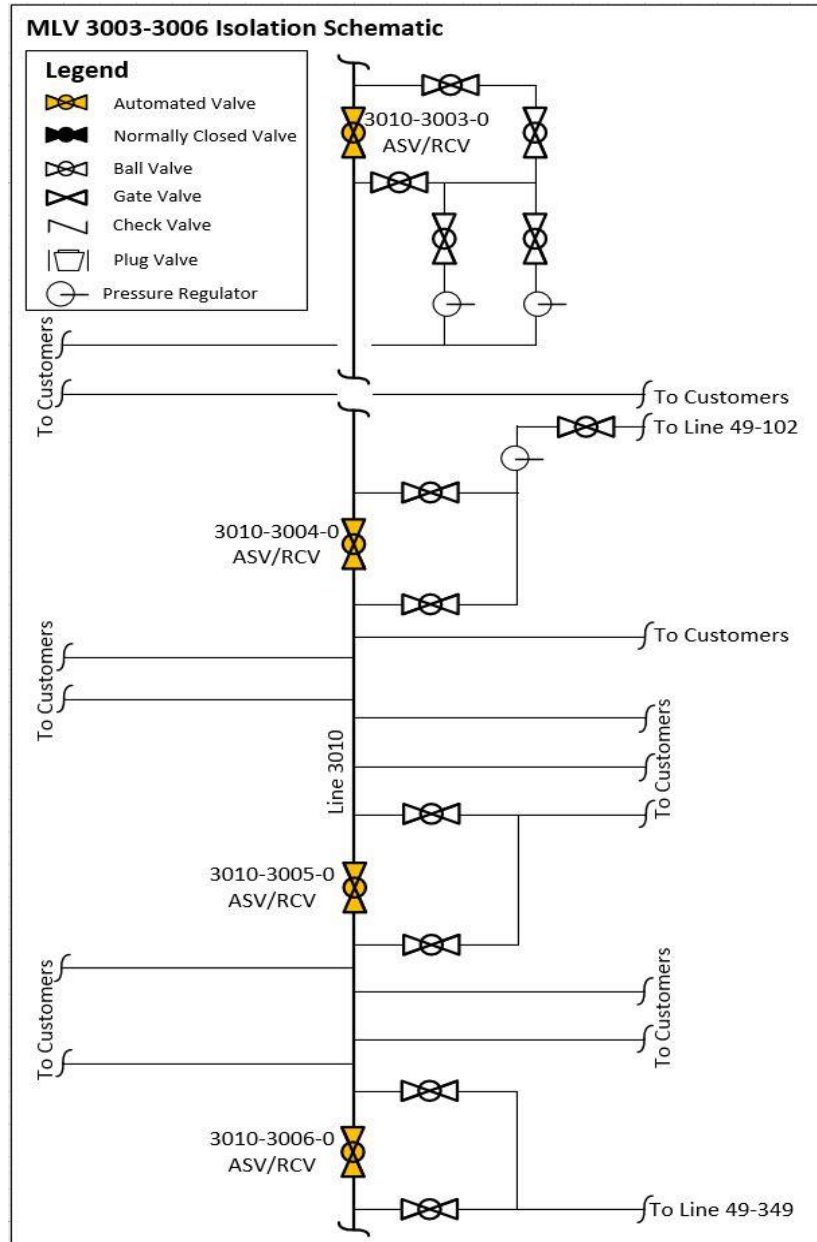

Pipeline Safety Enhancement Plan Final Report Line 3010 Valve Enhancement Project Bundle

Figure 12: Line 3010 Valve Enhancement Project Bundle Schematic:
3010-3007 to 3010-3008

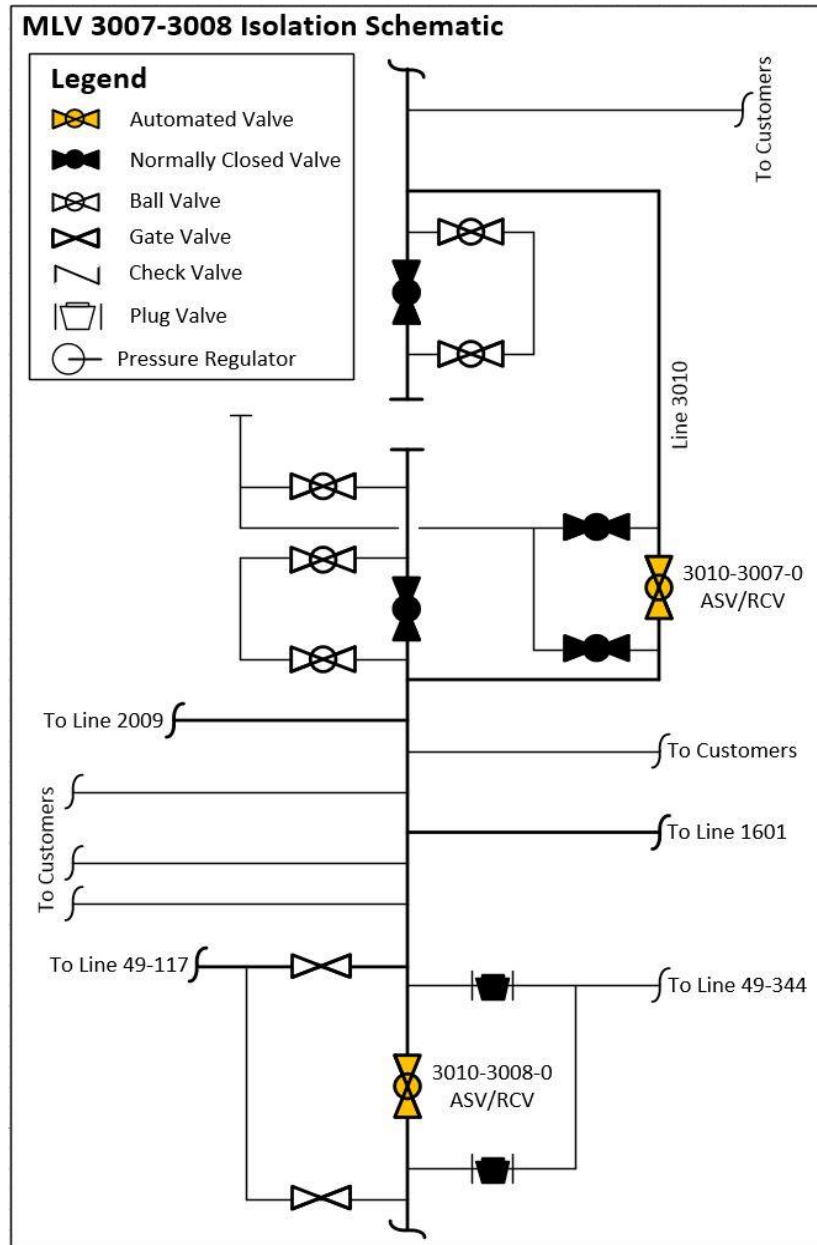

Pipeline Safety Enhancement Plan Final Report Line 3010 Valve Enhancement Project Bundle

Figure 13: Line 3010 Valve Enhancement Project Bundle Schematic:
3010-3007 to 3010-3008

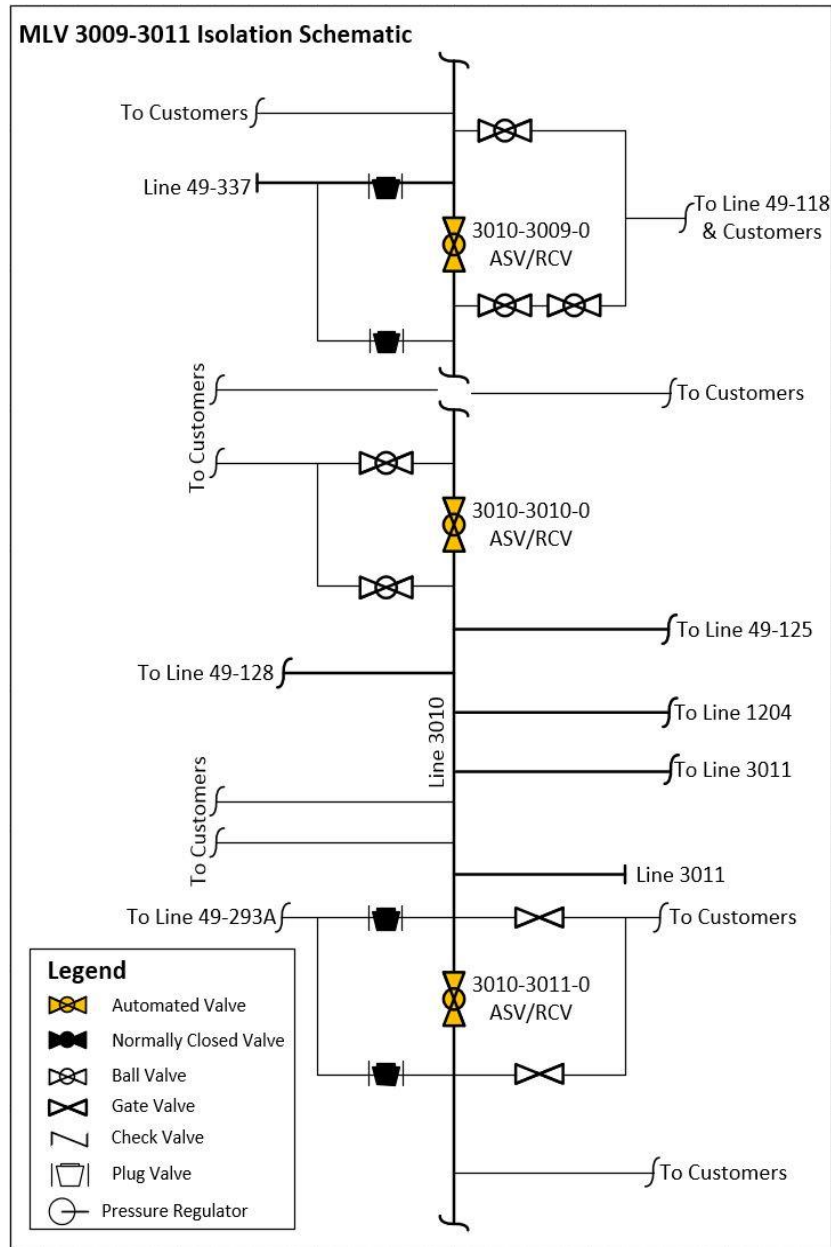

Pipeline Safety Enhancement Plan Final Report
Line 3010 Valve Enhancement Project Bundle

D. Scope Changes

SoCalGas and SDG&E did not make any notable scope changes during detailed design.

Pipeline Safety Enhancement Plan Final Report
Line 3010 Valve Enhancement Project Bundle

III. CONSTRUCTION

A. Construction Contractor Selection

The Project Team prepared an initial cost estimate based on their previous experience at these sites. As indicated above, there were no applicable changes in scope between the time when the Project Team prepared the preliminary cost estimate and when the Alliance Partner (Electrical Contractor) prepared and submitted their estimate. The scope of work did not include any Mechanical Construction Contractor work.

1. SoCalGas and SDG&E's Preliminary Electrical Contractor Estimate (*confidential*):
SoCalGas and SDG&E's preliminary cost estimate for construction was [REDACTED].
2. Electrical Contractor's Estimate (*confidential*): The Electrical Contractor's estimate was [REDACTED], which was [REDACTED] than SoCalGas and SDG&E's preliminary cost estimate.

Pipeline Safety Enhancement Plan Final Report
Line 3010 Valve Enhancement Project Bundle

B. Construction Schedule

Table 3: Construction Timeline

Line 3010 Valve Enhancement Project Bundle	
Construction Start Date	12/22/2014
Construction Completion Date	07/27/2015
Days on Site	27 days (cumulative)
Commissioning Date	N/A

C. Changes During Construction

The conditions summarized below were encountered during construction. Activities to address or mitigate these conditions resulted in approximately \$4,830 in change orders.

All Sites

1. Field Design Change: The Project Team requested the existing gas vents be raised at all valve sites for additional clearance above cabinets.

Pipeline Safety Enhancement Plan Final Report
Line 3010 Valve Enhancement Project Bundle

Figure 14: Linebreak Cabinet (typical)

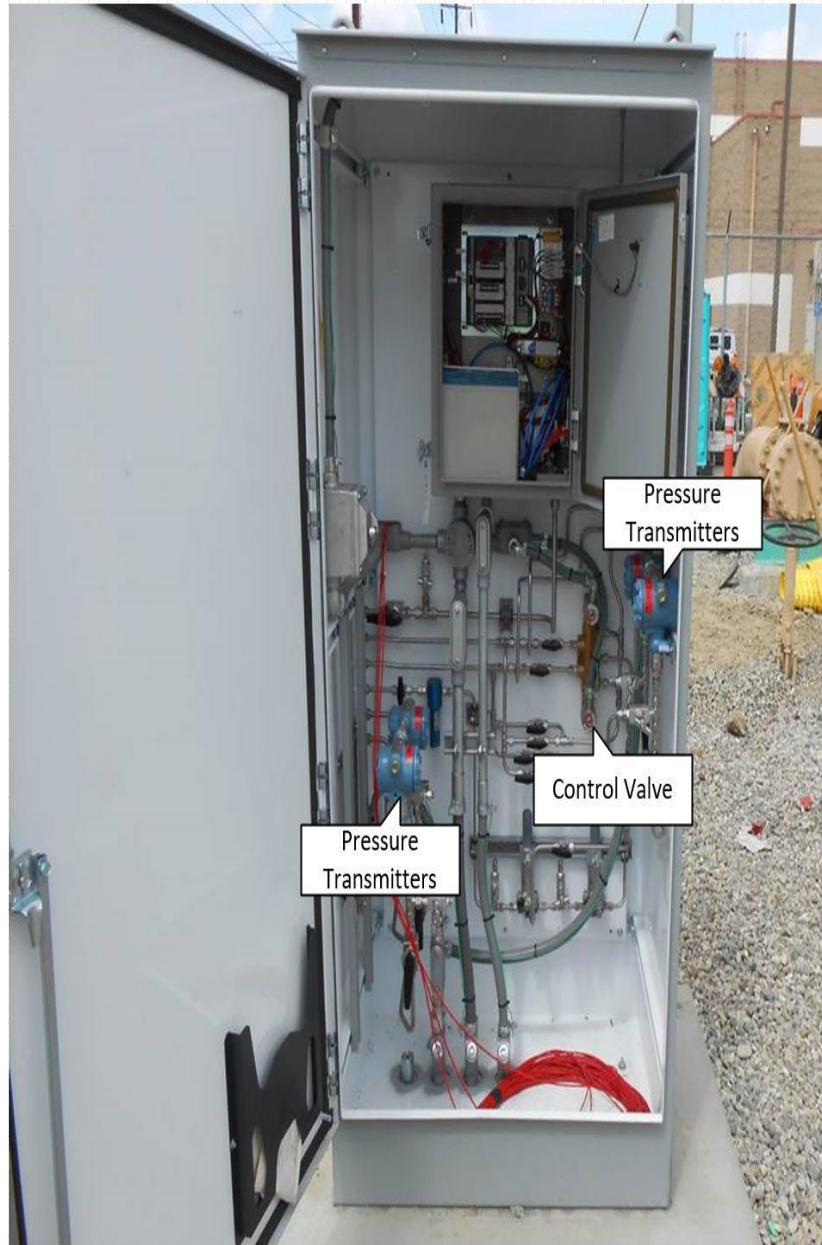

Pipeline Safety Enhancement Plan Final Report
Line 3010 Valve Enhancement Project Bundle

D. Commissioning and Site Restoration

The scope of work did not require commissioning activities. SoCalGas and SDG&E successfully performed site acceptance testing and conducted point-to-point verification with SoCalGas Gas Control personnel for the newly upgraded valves. SoCalGas and SDG&E trained Field Operations personnel on the proper use and operation of the new equipment. Closeout activities included development of final drawings, the reconciliation package, and updates to company recordkeeping systems to reflect the completed scope of work.

Pipeline Safety Enhancement Plan Final Report
Line 3010 Valve Enhancement Project Bundle

IV. PROJECT COSTS

A. Cost Avoidance Actions

SoCalGas and SDG&E exercised due diligence in the design, planning, and construction activities for this project to minimize or avoid costs when prudent to do so. As discussed above, the Project Team reviewed existing records, communicated with external stakeholders, and conducted a site walk to incorporate the site conditions in the project plan and design. The Project Team bundled the sites together to coordinate engineering activities between the nine sites.

B. Cost Estimates

Based on the preliminary design, once the preliminary project scope was confirmed and engineering, design, and planning activities were underway, SoCalGas and SDG&E prepared an estimate of the Direct Costs of the Project in the amount of \$315,766. The Project Team considered the conditions known at the time to prepare the preliminary Direct Cost estimate. This estimate reflects the projected Labor, Material, and Services costs anticipated to be incurred to execute the Project, based on initial design plans.

SoCalGas and SDG&E estimated Indirect Costs of the Project based on the estimated Direct Costs and other project-related variables.

C. Actual Direct and Indirect Costs

Actual Direct Costs reflect the Labor, Material, and Services costs incurred to execute the Project. Actual Indirect Costs reflect costs for incremental overhead loaders in accordance with Company overhead allocation policies. The total loaded cost of the Project is \$275,538.

Pipeline Safety Enhancement Plan Final Report
Line 3010 Valve Enhancement Project Bundle

Table 4: Estimated and Actual Direct Costs and Variances

Direct Costs (\$)	Estimate	Actuals	Delta Over/(Under)
Company Labor	35,406	16,404	(19,002)
Materials	91,014	74,909	(16,105)
Mechanical Construction Contractor	0	0	0
Electrical Contractor	73,369	66,591	(6,778)
Construction Management & Support	27,783	14,445	(13,338)
Environmental	-	3,774	3,774
Engineering & Design	39,478	13,777	(25,701)
Project Management & Services	21,258	7,625	(13,633)
ROW & Permits	-	130	130
GMA	27,458	15,830	(11,628)
Total Direct Costs	315,766	213,485	(102,281)

Table 5: Estimated and Actual Indirect Costs, Total Costs, and Variances

Indirect Costs/Total Costs (\$)	Estimate	Actuals	Delta Over/(Under)
Overheads	29,177	41,848	12,671
AFUDC	5,485	16,378	10,893
Property Taxes	-	3,827	3,827
Total Indirect Costs	34,662	62,053	27,391
Total Direct Costs	315,766	213,485	(102,281)
Total Loaded Costs	350,428	275,538	(74,890)

Pipeline Safety Enhancement Plan Final Report
Line 3010 Valve Enhancement Project Bundle

V. CONCLUSION

SoCalGas and SDG&E enhanced the safety of their integrated natural gas system by prudently executing the Line 3010 Valve Enhancement Project Bundle. Through this Valve Enhancement Project Bundle, SoCalGas and SDG&E successfully upgraded nine mainline valves to achieve the objective of enabling rapid system isolation in the Greater San Diego area. The total loaded cost of the Project is \$275,538.

SoCalGas and SDG&E executed this project prudently through bundling nine valve sites and executing as one project.

SoCalGas and SDG&E engaged in prudent cost avoidance efforts to complete this safety enhancement project at a reasonable cost by planning and coordinating construction activities to minimize impact to customers and the community.

End of Line 3010 Valve Enhancement Project Bundle Final Report